

B.P.DEMIDOVICH

**MATEMATIK ANALIZDAN
MISOL VA MASALALAR
TO`PLAMI**

(1-2500)

Ruschadan R.Xakimov tarjimasi

Oliy o`quv yurtlarining matematika, amaliy matematika
va fizika ta`lim yo`nalishlari talabalari uchun

O`QUV QO`LLANMA

Namangan Davlat universiteti

2019

UDK 517 (075.8)
BBK 22.161
D30

Demidovich B.P.

Matematik tahlildan misol va masalalar to`plami: O`quv qo`llanma. Ruschadan tarjima – NamDU, 2019.- 130 bet.

Tarjimon: R. Xakimov

EHM ustasi: M. Xakimov

Texnik muharrir: T.Ergashev

To`plamga matematik analizning to`rtta muhim bo`limlaridan 2500 ta misol va masalalar kiritilgan: analizga kirish, bir o`zgaruvchili funksiyaning differensial hisobi, aniqmas integral va aniq integral. Deyarli barcha masalalarga javoblar berilgan.

Universitet va pedagogika institutlarining matematika, amaliy matematika va fizika ta`lim yo`nalishlari talabalari uchun mo`ljallangan.

MUNDARIJA

BIR O`ZGARUVCHILI FUNKSIYA

I bo`lim. Analizga kirish	6
1. Haqiqiy sonlar	6
2. Ketma-ketlik nazariyasi	8
3. Funksiya tushunchasi	15
4. Funksiya grafigi	20
5. Funksiya limiti	28
6. O – simbolika	41
7. Uzluksiz funksiya	43
8. Teskari funksiya. Parametrik ko`rinishda berilgan funksiyalar.....	49
9. Tekis uzluksiz funksiya	51
10. Funktsional tenglamalar	53
II bo`lim. Bir o`zgaruvchili funksiyaning differensial hisobi.....	55
1. Funksiya hosilasi	55
2. Teskari funksiya hosilasi. Parametrik ko`rinishda berilgan funksiya hosilasi. Oshkormas funksiya hosilasi	66
3. Hosilaning geometrik ma`nosi	67
4. Funksiya differensial	69
5. Yuqori tartibli hosila va differensiallar	71
6. Roll', Lagranj va Koshi teoremlari	77
7. Funksiyaning o`shishi va kamayishi. Tengsizliklar	81
8. Botiqlik yo`nalishlari. egilish nuqtalari	83
9. Aniqmasliklarni ochish	85
10. Teylor formulasi	87
11. Funksiya ekstremumi. Funksiyaning eng katta va eng kichik qiymatlari	90
12. Funksiya grafigini yasash.....	93
13. Funksiyaning maksimum va minimumiga doir masalalar	95
14. Egri chiziqning urinishi. egrilik doirasi. evolyuta	97
15. Tenglamalarni taqribiy echish	98
III bo`lim. Aniqmas integral	99
1. Sodda aniqmas integrallar	99
2. Ratsional funksiyalarni integrallash	105
3. Ba`zi irratsional funksiyalarni integrallash	108
4. Trigonometrik funksiyalarni integrallash	110
5. Turli transtsendent funksiyalarni integrallash	114
6. Funksiyalarni integrallashga turli misollar	116
IV bo`lim. Aniq integral	119
1. Aniq integral yig`indining limiti sifatida.....	119
2. Aniq integrallarni aniqmas integrallar yordamida hisoblash	122
3. O`rta qiymat haqida teoremlar	128
4. Xosmas integrallar	130
5. Yuzalarni hisoblash	134
6. Yoy uzunligini hisoblash	135
7. Hajmlarni hisoblash	136
8. Aylanma sirt yuzalarini hisoblash	138

I BO`LIM

ANALIZGA KIRISH

1. Haqiqiy sonlar

Matematik induksiya usulini qo`llab, quyidagi tengliklar o`rinli ekanini isbotlang (1-4):

$$1. 1 + 2 + 3 + \dots + n = \frac{n(n+1)}{2}. \quad 2. 1^2 + 2^2 + \dots + n^2 = \frac{n(n+1)(2n+1)}{6}.$$

$$3. 1^3 + 2^3 + \dots + n^3 = (1 + 2 + \dots + n)^2. \quad 4. 1 + 2 + 2^2 + \dots + 2^{n-1} = 2^n - 1.$$

5. $a^{[n]} = a(a-h)\dots(a-(n-1)h)$ va $a^{[0]} = 1$ bo`lsin. Quyidagini isbotlang:

$$(a+b)^{[n]} = \sum_{m=0}^n C_n^m a^{[n-m]} b^{[m]}, \text{ bu erda } C_n^m - n \text{ elementdan } m \text{ tadan guruhlashlar soni. Bundan}$$

N'yuton binomi formulasini keltirib chiqaring.

6. Quyidagi Bernulli tengsizligini isbotlang:

$$(1+x_1)(1+x_2)\dots(1+x_n) \geq 1+x_1+x_2+\dots+x_n,$$

bu erda x_1, x_2, \dots, x_n sonlar -1 dan katta bo`lgan ishorasi bir xil sonlar.

7. $x > -1$, $n > 1$ bo`lganda $(1+x)^n \geq 1+nx$ ekanini isbotlang, bunda tenglik belgisi faqat $x = 0$ da o`rinli.

8. Tengsizlikni isbotlang: $n! < \left(\frac{n+1}{2}\right)^n$, $n > 1$.

Y o` l l a n m a. $\left(\frac{n+2}{n+1}\right)^{n+1} = \left(1 + \frac{1}{n+1}\right)^{n+1} > 2$, $n = 1, 2, \dots$ tengsizlikdan foydalaning.

9. Tengsizlikni isbotlang: $2! \cdot 4! \cdot \dots \cdot (2n)! > [(n+1)!]^n$, $n > 1$

10. Tengsizlikni isbotlang: $\frac{1}{2} \cdot \frac{3}{4} \cdot \dots \cdot \frac{2n-1}{2n} < \frac{1}{\sqrt{2n+1}}$.

10. 1. Tengsizliklarni isbotlang:

$$a) 1 + \frac{1}{\sqrt{2}} + \frac{1}{\sqrt{3}} + \dots + \frac{1}{\sqrt{n}} > \sqrt{n}, n \geq 2; \quad b) n^{n+1} > (n+1)^n, n \geq 3;$$

$$v) \left| \sin \left(\sum_{k=1}^n x_k \right) \right| \leq \sum_{k=1}^n \sin x_k, 0 \leq x_k \leq p, k = \overline{1, n}; \quad g) (2n)! < 2^{2n} (n!)^2.$$

11. c - butun sonning kvadrati bo`lmagan musbat son, A/B esa \sqrt{c} haqiqiy sonni aniqlovchi kesim bo`lsin, bu erda B sinf $b^2 > c$ shartni qanoatlantiruvchi barcha b musbat ratsional sonlardan, A sinf qolgan ratsional sonlardan iborat. A sinfda eng katta son, B sinfda eng kichik son mavjud emasligini isbotlang.

12. $\sqrt[3]{2}$ sonni aniqlovchi A/B kesim quyidagicha quriladi: A sinf $a^3 < 2$ shartni qanoatlantiruvchi barcha a ratsional sonlardan; B sinf qolgan ratsional sonlardan iborat. A sinfda eng katta son, B sinfda eng kichik son mavjud emasligini isbotlang.

13. Mos kesimlarni qurib tengliklarni isbotlang:

$$a) \sqrt{2} + \sqrt{8} = \sqrt{18}; \quad b) \sqrt{2}\sqrt{3} = \sqrt{6}.$$

14. $2^{\sqrt{2}}$ sonni aniqlovchi kesimni quring.

15. Har qanday bo`sh bo`lmagan quyidan chegaralangan sonli to`plam aniq quyi chegaraga, har qanday bo`sh bo`lmagan yuqoridan chegaralangan sonli to`plam esa aniq yuqori chegaraga ega ekanligini isbotlang.

38. Kvadratning yuzini $0,001 \text{ m}^2$ gacha aniqlikda aniqlash imkoniyati bo`lishi uchun uning x ($2 \text{ m} < x < 3 \text{ m}$) tomonini qanday absolyut xatolik bilan o`lchash kerak?

39. To`g`ri to`rtburchakning yuzini $0,01 \text{ m}^2$ gacha aniqlikda hisoblash uchun uning x, y ($x \leq 10 \text{ m}, y \leq 10 \text{ m}$) tomonlarini qanday Δ absolyut xatolik bilan o`lchash kerak?

40. $d(x)$ va $d(y)$ - x va y sonlarining nisbiy xatoligi, $d(xy)$ esa xy sonning nisbiy xatoligi bo`lsin. U holda

$$d(xy) \leq d(x) + d(y) + d(x)d(y)$$

ekanini isbotlang.

2. Ketma-ketliklar nazariyasi

41. Ketma-ketlik limitining ta`rifidan foydalanib $x_n = \frac{n}{n+1}$, $n = 1, 2, \dots$ ketma-ketlik uchun

$\lim_{n \rightarrow \infty} x_n = 1$ ekanini isbotlang, ya`ni ixtiyoriy $\epsilon > 0$ uchun $n > N$ bo`lganda $|x_n - 1| < \epsilon$ tengsizlik bajariladigan $N(\epsilon)$ sonni toping.

Quyidagi jadvalni to`ldiring:

ϵ	0,1	0,01	0,001	0,0001	...
N					

42. Agar

a) $x_n = \frac{(-1)^{n+1}}{n}$; b) $x_n = \frac{2n}{n^3 + 1}$; v) $x_n = \frac{1}{n!}$; g) $x_n = (-1)^n \cdot 0,999^n$.

bo`lsa, x_n ($n = 1, 2, \dots$) ketma-ketlik cheksiz kichik ($\lim_{n \rightarrow \infty} x_n = 0$) ekanini isbotlang, ya`ni ixtiyoriy $\epsilon > 0$ uchun $n > N$ bo`lganda $|x_n| < \epsilon$ tengsizlik bajariladigan $N(\epsilon)$ sonni ko`rsating.

YUqoridagi har bir hol uchun quyidagi jadvalni to`ldiring:

ϵ	0,1	0,01	0,001	0,0001	...
N					

43. Quyidagi

a) $x_n = (-1)^n \cdot n$; b) $x_n = 2^{\sqrt{n}}$; v) $x_n = \lg(\lg n)$, $n \geq 2$

ketma-ketliklar cheksiz katta ($\lim_{n \rightarrow \infty} x_n = \infty$) ekanligini isbotlang, ya`ni ixtiyoriy etarlicha katta $E > 0$ uchun $n > N$ bo`lganda $|x_n| > E$ tengsizlik bajariladigan $N(E)$ sonni ko`rsating.

YUqoridagi har bir hol uchun quyidagi jadvalni to`ldiring:

E	10	100	1000	10000	...
N					

44. $x_n = n^{(-1)^n}$ ($n = 1, 2, \dots$) ketma-ketlik chegaralanmagan va shu bilan birga $n \rightarrow \infty$ da cheksiz katta emasligini isbotlang.

45. Quyidagi tasdiqlarni tengsizliklar yordamida yozing:

a) $\lim_{n \rightarrow \infty} x_n = \infty$; b) $\lim_{n \rightarrow \infty} x_n = -\infty$; v) $\lim_{n \rightarrow \infty} x_n = +\infty$.

Quyidagi limitlarni aniqlang (46-57, $n \in N$):

$$46. \lim_{n \rightarrow \infty} \frac{10000n}{n^2 + 1}.$$

$$48. \lim_{n \rightarrow \infty} \frac{\sqrt[3]{n^2} \sin n!}{n+1}.$$

$$50. \lim_{n \rightarrow \infty} \frac{1+a+a^2+\dots+a^n}{1+b+b^2+\dots+b^n}, \quad |a| < 1, \quad |b| < 1.$$

$$52. \lim_{n \rightarrow \infty} \left| \frac{1}{n} - \frac{2}{n} + \frac{3}{n} - \dots + \frac{(-1)^{n-1} n}{n} \right|.$$

$$54. \lim_{n \rightarrow \infty} \left(\frac{1^2}{n^3} + \frac{3^2}{n^3} + \dots + \frac{(2n-1)^2}{n^3} \right).$$

$$56. \lim_{n \rightarrow \infty} \left(\frac{1}{1 \cdot 2} + \frac{1}{2 \cdot 3} + \dots + \frac{1}{n(n+1)} \right).$$

$$47. \lim_{n \rightarrow \infty} (\sqrt{n+1} - \sqrt{n}).$$

$$49. \lim_{n \rightarrow \infty} \frac{(-2)^n + 3^n}{(-2)^{n+1} + 3^{n+1}}.$$

$$51. \lim_{n \rightarrow \infty} \left(\frac{1}{n^2} + \frac{2}{n^2} + \dots + \frac{n-1}{n^2} \right).$$

$$53. \lim_{n \rightarrow \infty} \left(\frac{1^2}{n^3} + \frac{2^2}{n^3} + \dots + \frac{(n-1)^2}{n^3} \right).$$

$$55. \lim_{n \rightarrow \infty} \left(\frac{1}{2} + \frac{3}{2^2} + \frac{5}{2^3} + \dots + \frac{2n-1}{2^n} \right).$$

$$57. \lim_{n \rightarrow \infty} (\sqrt{2} \cdot \sqrt[4]{2} \cdot \sqrt[8]{2} \cdot \dots \cdot \sqrt[2^n]{2})$$

Quyidagi tengliklarni isbotlang (58-66):

$$58. \lim_{n \rightarrow \infty} \frac{n}{2^n} = 0.$$

$$59. \lim_{n \rightarrow \infty} \frac{2^n}{n!} = 0.$$

$$60. \lim_{n \rightarrow \infty} \frac{n^k}{a^n} = 0 \quad (a > 1).$$

$$61. \lim_{n \rightarrow \infty} \frac{a^n}{n!} = 0.$$

$$62. \lim_{n \rightarrow \infty} n \cdot q^n = 0 \quad (|q| < 1).$$

$$63. \lim_{n \rightarrow \infty} \sqrt[n]{a} = 1.$$

$$64. \lim_{n \rightarrow \infty} \frac{\log_a n}{n} = 0, \quad a > 1.$$

$$65. \lim_{n \rightarrow \infty} \sqrt[n]{n} = 1.$$

$$66. \lim_{n \rightarrow \infty} \frac{1}{\sqrt[n]{n!}} = 0.$$

67. Etarlicha katta n lar uchun qaysi ifoda katta:

a) $100n + 200$ yoki $0,01n^2$?;

b) 2^n yoki n^{1000} ?;

v) 1000^n yoki $n!$?

$$68. \text{Isbotlang: } \lim_{n \rightarrow \infty} \left(\frac{1}{2} \cdot \frac{3}{4} \cdot \dots \cdot \frac{2n-1}{2n} \right) = 0.$$

Y o`ll a n m a. 10 - misolga qarang.

$$69. x_n = \left(1 + \frac{1}{n} \right)^n \quad (n = 1, 2, \dots) \text{ ketma-ketlik monoton o`svuchi va yuqoridan chegaralangan,}$$

$$y_n = \left(1 + \frac{1}{n} \right)^{n+1} \quad (n = 1, 2, \dots) \text{ ketma-ketlik esa monoton kamayuvchi va quyidan chegaralangan}$$

ekanligini isbotlang. Bundan, bu ketma-ketliklar ushbu

$$\lim_{n \rightarrow \infty} \left(1 + \frac{1}{n} \right)^n = \lim_{n \rightarrow \infty} \left(1 + \frac{1}{n} \right)^{n+1} = e$$

umumiy limitga ekanligini ko`rsating.

70. Isbotlang: $0 < e - \left(1 + \frac{1}{n} \right)^n < \frac{3}{n} \cdot \left(1 + \frac{1}{n} \right)^n$ ifoda n darajaning qanday qiymatlari-da e sonidan 0,001 dan kichik songa farq qiladi?

71. $\lim_{n \rightarrow \infty} p_n = +\infty$, $\lim_{n \rightarrow \infty} q_n = -\infty$ ($p_n, q_n \notin [-1, 0]$) shartlarni qanoatlantiruvchi ixtiyoriy p_n ($n = 1, 2, \dots$) va q_n ($n = 1, 2, \dots$) sonli ketma-ketliklar berilgan bo`lsin. Isbotlang:

$$\lim_{n \rightarrow \infty} \left(1 + \frac{1}{p_n} \right)^{p_n} = \lim_{n \rightarrow \infty} \left(1 + \frac{1}{q_n} \right)^{q_n} = e.$$

72. Agar $\lim\left(1 + \frac{1}{n}\right)^n = e$ ekanligi ma'lum bo'lsa, u holda

$$\lim_{n \rightarrow \infty} \left(1 + 1 + \frac{1}{2!} + \frac{1}{3!} + \dots + \frac{1}{n!}\right) = e$$

tenglikni isbotlang. Bundan ushbu

$$e = 2 + \frac{1}{2!} + \frac{1}{3!} + \dots + \frac{1}{n!} + \frac{q_n}{n! \cdot n}$$

formulani keltirib chiqaring, bunda $0 < q_n < 1$, va e sonini 10^{-5} aniqlikda hisoblang.

73. e sonini irratsional ekanligini isbotlang.

74. Tengsizlikni isbotlang: $\left(\frac{n}{e}\right)^n < n! < e\left(\frac{n}{2}\right)^n$.

75. Tengsizliklarni isbotlang:

a) $\frac{1}{n+1} < \ln\left(1 + \frac{1}{n}\right) < \frac{1}{n}$, n - ixtiyoriy natural son;

b) $1 + a < e^a$, a - noldan farqli haqiqiy son.

76. Isbotlang: $\lim_{n \rightarrow \infty} n\left(a^{\frac{1}{n}} - 1\right) = \ln a$ ($a > 0$), bunda $\ln a$ son $e = 2,718\dots$ asosga ko'ra a

sonning logarifmi.

Monoton va chegaralangan ketma-ketlik limitining mavjudligi haqida teoremdan foydalanib, quyidagi ketma-ketliklarning yaqinlashuvchi ekanligini isbotlang (77-81):

77. $x_n = p_0 + \frac{p_1}{10} + \dots + \frac{p_n}{10^n}$ ($n = 1, 2, \dots$), bunda $p_i \geq 0$ ($i = 0, 1, 2, \dots$), $p_i \leq 9$ ($i = 1, 2, \dots$)

shartlarni qanoatlantiruvchi butun sonlar.

78. $x_n = \frac{10}{1} \cdot \frac{11}{3} \cdot \frac{12}{5} \cdot \dots \cdot \frac{n+9}{2n-1}$.

79. $x_n = \left(1 - \frac{1}{2}\right) \left(1 - \frac{1}{4}\right) \dots \left(1 - \frac{1}{2^n}\right)$.

80. $x_n = \left(1 + \frac{1}{2}\right) \left(1 + \frac{1}{4}\right) \dots \left(1 + \frac{1}{2^n}\right)$.

81. $x_1 = \sqrt{2}$, $x_2 = \sqrt{2 + \sqrt{2}}$, \dots , $x_n = \sqrt{2 + \sqrt{2 + \sqrt{2 + \dots + \sqrt{2}}}}$, \dots

Koshi kriteriysidan foydalanib, quyidagi ketma-ketliklarning yaqinlashuvchi ekanligini isbotlang (82-85):

82. $x_n = a_0 + a_1 q + \dots + a_n q^n$, bunda $|a_k| < M$ ($k = 0, 1, 2, \dots$) va $|q| < 1$.

83. $x_n = \frac{\sin 1}{2} + \frac{\sin 2}{2^2} + \dots + \frac{\sin n}{2^n}$.

84. $x_n = \frac{\cos 1!}{1 \cdot 2} + \frac{\cos 2!}{2 \cdot 3} + \dots + \frac{\cos n!}{n(n+1)}$.

85. $x_n = 1 + \frac{1}{2^2} + \frac{1}{3^2} + \dots + \frac{1}{n^2}$.

Y o`l l a n m a. $\frac{1}{n^2} < \frac{1}{n-1} - \frac{1}{n}$ ($n = 2, 3, \dots$) tengsizlikdan foydalaning.

86. Agar x_n ($n = 1, 2, \dots$) ketma-ketlik uchun

$$|x_2 - x_1| + |x_3 - x_2| + \dots + |x_n - x_{n-1}| < C \quad (n = 2, 3, \dots)$$

shartni qanoatlantiruvchi C son mavjud bo'lsa, bu ketma-ketlik chegaralangan o'zgarishga ega deyiladi.

CHegaralangan o'zgarishga ega ketma-ketlik yaqinlashuvchi bo'lishini isbotlang.

YAqinlashuvchi, lekin chegaralangan o'zgarishga ega bo'lmagan ketma-ketlikka misol quring.

87. Berilgan ketma-ketlik uchun Koshi kriteriysi bajarilmaslik shartini yozing.

88. Koshi kriteriysidan foydalanib

$$x_n = 1 + \frac{1}{2} + \frac{1}{3} + \dots + \frac{1}{n}$$

ketma-ketlikning uzoqlashuvchi ekanligini isbotlang.

89. Agar x_n ($n = 1, 2, \dots$) ketma-ketlik yaqinlashuvchi bo'lsa, u holda uning ixtiyoriy x_{p_n} qism ketma-ketligi ham yaqinlashuvchi va

$$\lim_{n \rightarrow \infty} x_{p_n} = \lim_{n \rightarrow \infty} x_n$$

tenglik o'rinli ekanini isbotlang.

90. Agar monoton ketma-ketlikning biror qism ketma-ketligi yaqinlashuvchi bo'lsa, u holda bu ketma-ketlik yaqinlashuvchi bo'lishini isbotlang.

91. Agar $\lim_{n \rightarrow \infty} x_n = a$ bo'lsa, u holda $\lim_{n \rightarrow \infty} |x_n| = |a|$ bo'lishini isbotlang.

92. Agar $\lim_{n \rightarrow \infty} x_n = a$ bo'lsa, $\lim_{n \rightarrow \infty} \frac{x_{n+1}}{x_n}$ haqida nima deyish mumkin?

93. YAqinlashuvchi ketma-ketlik chegaralangan ekanligini isbotlang.

94. YAqinlashuvchi ketma-ketlik o'zining aniq quyi chegarasi yoki aniq yuqori chegarasi yoki ikkalasiga ega bo'lishini isbotlang. Uchchala holga misollar quring.

95. Agar $\lim_{n \rightarrow \infty} x_n = +\infty$ bo'lsa, u holda x_n ($n = 1, 2, \dots$) ketma-ketlik albatta o'zining aniq quyi chegarasiga ega bo'lishini isbotlang.

Quyidagi x_n ($n = 1, 2, \dots$) ketma-ketliklarning eng katta hadini toping (96-98):

$$96. x_n = \frac{n^2}{2^n}. \quad 97. x_n = \frac{\sqrt{n}}{100+n}. \quad 98. x_n = \frac{1000^n}{n!}.$$

Quyidagi x_n ($n = 1, 2, \dots$) ketma-ketliklarning eng kichik hadini toping (99-100):

$$99. x_n = n^2 - 9n - 100. \quad 100. x_n = n + \frac{100}{n}.$$

Quyidagi x_n ($n = 1, 2, \dots$) ketma-ketliklar uchun $\inf x_n$, $\sup x_n$, $\underline{\lim}_{n \rightarrow \infty} x_n$, $\overline{\lim}_{n \rightarrow \infty} x_n$ larni toping (101-110):

$$101. x_n = 1 - \frac{1}{n}. \quad 101.1. x_n = (-1)^{n-1} \left(2 + \frac{3}{n} \right).$$

$$102. x_n = \frac{(-1)^n}{n} + \frac{1 + (-1)^n}{2}. \quad 103. x_n = 1 + \frac{n}{n+1} \cos \frac{np}{2}.$$

$$104. x_n = 1 + 2(-1)^{n+1} + 3(-1)^{\frac{n(n-1)}{2}}. \quad 105. x_n = \frac{n-1}{n+1} \cos \frac{2np}{3}.$$

$$106. x_n = (-1)^n \cdot n. \quad 107. x_n - n \left[2 + (-1)^n \right].$$

$$108. x_n = n^{(-1)^n}. \quad 109. x_n = 1 + n \sin \frac{np}{2}.$$

$$110. x_n = \frac{1}{n-10,2}.$$

Quyidagi x_n ($n = 1, 2, \dots$) ketma-ketliklar uchun $\underline{\lim}_{n \rightarrow \infty} x_n$, $\overline{\lim}_{n \rightarrow \infty} x_n$ larni toping (111-115):

$$111. x_n = \frac{n^2}{1+n} \cos \frac{2np}{3}. \quad 112. x_n = \left(1 + \frac{1}{n} \right)^n (-1)^n + \sin \frac{np}{4}.$$

$$113. x_n = \frac{n}{n+1} \sin^2 \frac{np}{4}.$$

$$114. x_n = \sqrt[n]{1+2^{n(-1)^n}}.$$

$$115. x_n = \cos^n \frac{2np}{3}.$$

Quyidagi ketma-ketliklarning xususiy limitlarini toping (116-120):

$$116. \frac{1}{2}, \frac{1}{2}, \frac{1}{4}, \frac{3}{4}, \frac{1}{8}, \frac{7}{8}, \dots, \frac{1}{2^n}, \frac{2^n-1}{2^n}, \dots$$

$$117. 1, \frac{1}{2}, 1+\frac{1}{2}, \frac{1}{3}, 1+\frac{1}{3}, \frac{1}{2}+\frac{1}{3}, \frac{1}{4}, 1+\frac{1}{4}, \frac{1}{2}+\frac{1}{4}, \frac{1}{3}+\frac{1}{4}, \frac{1}{5}, \dots$$

$$\dots, \frac{1}{n}, 1+\frac{1}{n}, \frac{1}{2}+\frac{1}{n}, \dots, \frac{1}{n-1}+\frac{1}{n}, \frac{1}{n+1}, \dots$$

$$118. \frac{1}{2}, \frac{1}{3}, \frac{2}{3}, \frac{1}{4}, \frac{2}{4}, \frac{3}{4}, \frac{1}{5}, \frac{2}{5}, \frac{3}{5}, \frac{4}{5}, \dots$$

$$119. x_n = 3\left(1 - \frac{1}{n}\right) + 2(-1)^n.$$

$$120. x_n = \frac{1}{2} \left[(a+b) + (-1)^n (a-b) \right].$$

121. a_1, a_2, \dots, a_p xususiy limitlarga ega bo'lgan sonli ketma-ketlikka misol keltirib.

122. Barcha $a_1, a_2, \dots, a_n, \dots$ hadlari o'zining xususiy limitlari bo'lgan sonli ketma-ketlikka misol quring. Qurilgan ketma-ketlik yana qanday xususiy limitlarga albatta ega?

123. Ketma-ketlikka misol quring:

- a) Chekli xususiy limitlarga ega bo'lmagan;
- b) Yagona chekli xususiy limitga ega bo'lib, yaqinlashuvchi bo'lmaydigan;
- v) Cheksiz ko'p xususiy limitlarga ega bo'lgan;
- g) Har bir haqiqiy son uning xususiy limiti bo'lgan.

124. x_n va $y_n = x_n \sqrt[n]{n}$ ($n=1, 2, \dots$) ketma-ketliklar umumiy xususiy limitlarga ega ekanligini isbotlang.

125. Chegaralangan x_n ($n=1, 2, \dots$) ketma-ketlikdan har doim yaqinlashuvchi x_{p_n} ($n=1, 2, \dots$) qism ketma-ketlik ajratib olish mumkinligini isbotlang.

126. Agar x_n ($n=1, 2, \dots$) ketma-ketlik chegaralanmagan bo'lsa, u holda $\lim_{n \rightarrow \infty} x_{p_n} = \infty$ bo'lgan x_{p_n} qism ketma-ketlik mavjud ekanligini isbotlang.

127. x_n ($n=1, 2, \dots$) ketma-ketlik yaqinlashuvchi, y_n ($n=1, 2, \dots$) ketma-ketlik esa uzoqlashuvchi bo'lsin. Quyidagi ketma-ketliklarning yaqinlashishi haqida nima deyish mumkin:

- a) $x_n + y_n$;
- b) $x_n y_n$?

Misollar keltiring.

128. x_n va y_n ($n=1, 2, \dots$) ketma-ketliklar uzoqlashuvchi bo'lsin. U holda ushbu

- a) $x_n + y_n$;
- b) $x_n y_n$

ketma-ketliklar ham uzoqlashuvchi bo'ladimi? Misollar keltiring.

129. $\lim_{n \rightarrow \infty} x_n = 0$, va y_n ($n=1, 2, \dots$) - ixtiyoriy ketma-ketlik bo'lsin. U holda $\lim_{n \rightarrow \infty} x_n y_n = 0$ tenglik to'g'rimi? Misollar keltiring.

130. $\lim_{n \rightarrow \infty} x_n y_n = 0$ tenglikdan yo $\lim_{n \rightarrow \infty} x_n = 0$ yo $\lim_{n \rightarrow \infty} y_n = 0$ ekanligi kelib chiqadimi?

Quyidagi misolni ko'ring:

$$x_n = \frac{1+(-1)^n}{2}, \quad y_n = \frac{1-(-1)^n}{2} \quad (n=1, 2, \dots).$$

131. Isbotlang:

$$a) \lim_{n \rightarrow \infty} x_n + \lim_{n \rightarrow \infty} y_n \leq \lim_{n \rightarrow \infty} (x_n + y_n) \leq \overline{\lim}_{n \rightarrow \infty} x_n + \overline{\lim}_{n \rightarrow \infty} y_n;$$

$$b) \liminf_{n \rightarrow \infty} x_n + \overline{\lim}_{n \rightarrow \infty} y_n \leq \overline{\lim}_{n \rightarrow \infty} (x_n + y_n) \leq \overline{\lim}_{n \rightarrow \infty} x_n + \overline{\lim}_{n \rightarrow \infty} y_n.$$

Bu munosabatlarda qat'iy tengsizliklar o'rinli bo'ladigan hollarga misollar quring.

132. $x_n \geq 0$ va $y_n \geq 0$ ($n = 1, 2, \dots$) bo'lsin. Isbotlang:

$$a) \liminf_{n \rightarrow \infty} x_n \cdot \liminf_{n \rightarrow \infty} y_n \leq \liminf_{n \rightarrow \infty} (x_n \cdot y_n) \leq \overline{\lim}_{n \rightarrow \infty} x_n \cdot \overline{\lim}_{n \rightarrow \infty} y_n;$$

$$b) \overline{\lim}_{n \rightarrow \infty} x_n \cdot \overline{\lim}_{n \rightarrow \infty} y_n \leq \overline{\lim}_{n \rightarrow \infty} (x_n \cdot y_n) \leq \overline{\lim}_{n \rightarrow \infty} x_n \cdot \overline{\lim}_{n \rightarrow \infty} y_n.$$

Bu munosabatlarda qat'iy tengsizliklar o'rinli bo'ladigan hollarga misollar quring.

133. Agar $\lim_{n \rightarrow \infty} x_n$ mavjud bo'lsa, u holda ixtiyoriy y_n ($n = 1, 2, \dots$) ketma-ketlik uchun

$$a) \overline{\lim}_{n \rightarrow \infty} (x_n + y_n) = \lim_{n \rightarrow \infty} x_n + \overline{\lim}_{n \rightarrow \infty} y_n;$$

$$b) \overline{\lim}_{n \rightarrow \infty} (x_n \cdot y_n) = \lim_{n \rightarrow \infty} x_n \cdot \overline{\lim}_{n \rightarrow \infty} y_n \quad (x_n \geq 0)$$

bo'lishini isbotlang.

134. Agar biror x_n ($n = 1, 2, \dots$) ketma-ketlik uchun y_n ($n = 1, 2, \dots$) ketma-ketlik qanday bo'lishidan qat'iy nazar ushbu

$$a) \overline{\lim}_{n \rightarrow \infty} (x_n + y_n) = \overline{\lim}_{n \rightarrow \infty} x_n + \overline{\lim}_{n \rightarrow \infty} y_n;$$

$$b) \overline{\lim}_{n \rightarrow \infty} (x_n \cdot y_n) = \overline{\lim}_{n \rightarrow \infty} x_n \cdot \overline{\lim}_{n \rightarrow \infty} y_n \quad (x_n \geq 0)$$

tengliklardan hech bo'lmaganda bittasi o'rinli bo'lsa, x_n ($n = 1, 2, \dots$) ketma-ketlik yaqinlashuvchi bo'lishini isbotlang.

135. Agar $x_n > 0$ ($n = 1, 2, \dots$) va

$$\overline{\lim}_{n \rightarrow \infty} x_n \cdot \overline{\lim}_{n \rightarrow \infty} \frac{1}{x_n} = 1$$

bo'lsa, u holda x_n ($n = 1, 2, \dots$) ketma-ketlik yaqinlashuvchi bo'lishini isbotlang.

136. Agar x_n ($n = 1, 2, \dots$) ketma-ketlik chegaralangan va $\lim_{n \rightarrow \infty} (x_{n+1} - x_n) = 0$ bo'lsa, u holda bu ketma-ketlikning xususiy limitlari uning quyi va yuqori limitlari oralig'ining barcha joyida zich joylashgan:

$$l = \liminf_{n \rightarrow \infty} x_n, \quad L = \overline{\lim}_{n \rightarrow \infty} x_n,$$

ya'ni $[l, L]$ kesmadagi ixtiyoriy son berilgan ketma-ketlikning xususiy limiti bo'ladi.

137. $x_1, x_2, \dots, x_n, \dots$ sonli ketma-ketlik

$$0 \leq x_{m+n} \leq x_m + x_n \quad (m, n = 1, 2, \dots)$$

shartni qanoatlantirsin. U holda $\lim_{n \rightarrow \infty} \frac{x_n}{n}$ mavjud ekanligini isbotlang.

138. Agar x_n ($n = 1, 2, \dots$) ketma-ketlik yaqinlashuvchi bo'lsa, u holda

$$x_n = \frac{1}{n} (x_1 + x_2 + \dots + x_n) \quad (n = 1, 2, \dots)$$

o'rta arifmetik qiymatlari ketma-ketligi ham yaqinlashuvchi va

$$\lim_{n \rightarrow \infty} \frac{x_1 + x_2 + \dots + x_n}{n} = \lim_{n \rightarrow \infty} x_n$$

tenglik o'rinli ekanini isbotlang.

Bunga teskari tasdiq noto'g'ri: misol quring.

139. Agar $\lim_{n \rightarrow \infty} x_n = +\infty$ bo'lsa, $\lim_{n \rightarrow \infty} \frac{x_1 + x_2 + \dots + x_n}{n} = +\infty$ ekanligini isbotlang.

140. Agar x_n ($n = 1, 2, \dots$) ketma-ketlik yaqinlashuvchi va $x_n > 0$ bo'lsa, u holda

$$\lim_{n \rightarrow \infty} \sqrt[n]{x_1 x_2 \dots x_n} = \lim_{n \rightarrow \infty} x_n$$

tenglikni isbotlang.

141. Agar $x_n > 0$ ($n = 1, 2, \dots$) bo'lsa, u holda

$$\lim_{n \rightarrow \infty} \sqrt[n]{x_n} = \lim_{n \rightarrow \infty} \frac{x_{n+1}}{x_n}$$

ekanligini isbotlang, bunda tenglikning o'ng tomonidagi limit mavjud deb faraz qilamiz.

142. Isbotlang: $\lim_{n \rightarrow \infty} \frac{n}{\sqrt[n]{n!}} = e$.

143. SHtol'ts teoremasini isbotlang: Agar:

a) $y_{n+1} > y_n$ ($n = 1, 2, \dots$); b) $\lim_{n \rightarrow \infty} y_n = +\infty$, v) $\lim_{n \rightarrow \infty} \frac{x_{n+1} - x_n}{y_{n+1} - y_n}$ limit mavjud bo'lsa, u holda

$$\lim_{n \rightarrow \infty} \frac{x_n}{y_n} = \lim_{n \rightarrow \infty} \frac{x_{n+1} - x_n}{y_{n+1} - y_n}.$$

144. Toping: a) $\lim_{n \rightarrow +\infty} \frac{n^2}{a^n}$ ($a > 1$); b) $\lim_{n \rightarrow +\infty} \frac{\lg n}{n}$.

145. Agar p natural son bo'lsa, u holda quyidagilarni isbotlang:

a) $\lim_{n \rightarrow \infty} \frac{1^p + 2^p + 3^p + \dots + n^p}{n^{p+1}} = \frac{1}{p+1}$; b) $\lim_{n \rightarrow \infty} \left(\frac{1^p + 2^p + 3^p + \dots + n^p}{n^p} - \frac{n}{p+1} \right) = \frac{1}{2}$;

v) $\lim_{n \rightarrow \infty} \frac{1^p + 2^p + 3^p + \dots + (2n-1)^p}{n^{p+1}} = \frac{2^p}{p+1}$.

146. $x_n = 1 + \frac{1}{2} + \frac{1}{3} + \dots + \frac{1}{n} - \ln n$ ($n = 1, 2, \dots$) ketma-ketlik yaqinlashuvchi ekanligini isbotlang. Demak, ushbu

$$1 + \frac{1}{2} + \frac{1}{3} + \dots + \frac{1}{n} = C + \ln n + e_n$$

formula o'rinli, bunda $C = 0,577216\dots$ - eyler o'zgarmas soni va $n \rightarrow \infty$ da $e_n \rightarrow 0$.

147. Hisoblang: $\lim_{n \rightarrow \infty} \left(\frac{1}{n+1} + \frac{1}{n+2} + \dots + \frac{1}{2n} \right)$.

148. x_n ($n = 1, 2, \dots$) ketma-ketlik quyidagi formulalar bilan aniqlanadi:

$$x_1 = a, \quad x_2 = b, \quad x_n = \frac{x_{n-1} + x_{n-2}}{2} \quad (n = 3, 4, \dots). \quad \lim_{n \rightarrow \infty} x_n \text{ ni toping.}$$

149. x_n ($n = 1, 2, \dots$) ketma-ketlik quyidagi formulalar bilan aniqlanadi:

$$x_0 > 0, \quad x_{n+1} = \frac{1}{2} \left(x_n + \frac{1}{x_n} \right) \quad (n = 0, 1, 2, 3, \dots). \quad \lim_{n \rightarrow \infty} x_n = 1 \text{ ekanligini isbotlang.}$$

150. x_n, y_n ($n = 1, 2, \dots$) ketma-ketliklar quyidagi formulalar bilan aniqlanadi:

$$x_1 = a, \quad y_1 = b, \quad x_{n+1} = \sqrt{x_n y_n}, \quad y_{n+1} = \frac{x_n + y_n}{2}.$$

Bu ketma-ketliklar umumiy $m(a, b) = \lim_{n \rightarrow \infty} x_n = \lim_{n \rightarrow \infty} y_n$ limitga ega ekanligini isbotlang, bunda $m(a, b)$ - a va b sonlarning arifmetiko-geometrik o'rta qiymati.

3. Funksiya tushunchasi.

Quyidagi funksiyalarning aniqlanish sohasini toping (151-165.3):

151. $y = \frac{x^2}{1+x}$. 152. $y = \sqrt{3x-x^3}$. 153. $y = (x-2) \sqrt{\frac{1+x}{1-x}}$.

154. a) $y = \log(x^2 - 4)$; b) $y = \log(x+2) + \log(x-2)$.

$$155. y = \sqrt{\sin(\sqrt{x})}.$$

$$156. y = \sqrt{\cos x^2}.$$

$$157. y = \lg\left(\sin \frac{p}{x}\right).$$

$$158. y = \frac{\sqrt{x}}{\sin np x}.$$

$$159. y = \arcsin \frac{2x}{1+x}.$$

$$160. y = \arccos(2 \sin x).$$

$$161. y = \lg[\cos(\lg x)].$$

$$162. y = (x + |x|)\sqrt{x \sin^2 p x}.$$

$$163. y = \operatorname{ctg} p x + \arccos 2^x.$$

$$164. y = \arcsin(1-x) + \lg(\lg x).$$

$$165. y = (2x)!.$$

$$165.1. y = \log_2 \log_3 \log_4 x.$$

$$165.2. y = \sqrt[4]{\lg \operatorname{tg} x}.$$

$$165.3. y = \sqrt{\sin 2x} + \sqrt{\sin 3x} \quad (0 \leq x \leq 2p).$$

Quyidagi funksiyalarning aniqlanish sohasi va qiymatlari to'plamini aniqlang (166-170):

$$166. y = \sqrt{2+x-x^2}.$$

$$167. y = \lg(1-2 \cos x).$$

$$168. y = \arccos \frac{2x}{1+x^2}.$$

$$169. y = \arcsin\left(\lg \frac{x}{10}\right).$$

$$170. y = (-1)^x.$$

171. Asosi $AC = b$ va balandligi $BD = h$ bo'lgan ABC uchburchakka balandligi $NM = x$ bo'lgan $KLMN$ to'g'ri to'rtburchak ichki chizilgan. $KLMN$ to'g'ri to'rtburchakning P perimetri va S yuzasini x o'zgaruvchining funksiyasi sifatida ifodalang (1-rasm). $P = P(x)$ va $S = S(x)$ funksiyalarning grafiklarini yasang.

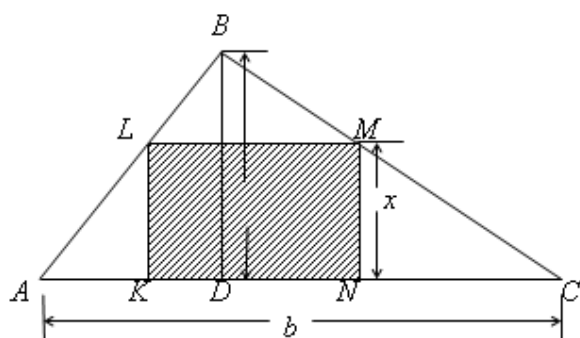

1-rasm

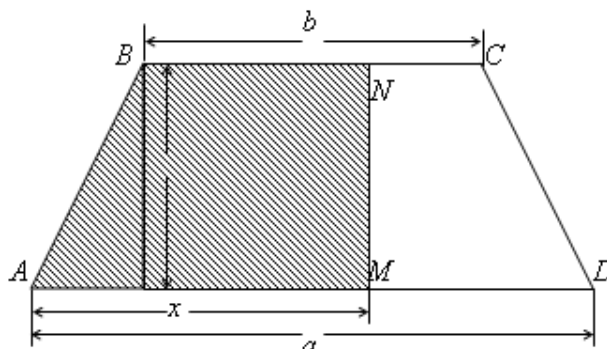

2-rasm

172. ABC uchburchakda $AB = 6$ sm, $AC = 8$ sm va $\angle BAC = x$. Uchburchakning $BC = a$ tomoni va S yuzasini x o'zgaruvchining funksiyasi sifatida ifodalang. $a = a(x)$ va $S = S(x)$ funksiyalarning grafiklarini yasang.

173. Asoslari $AD = a$, $BC = b$ ($a > b$) va balandligi $HB = h$ bo'lgan teng yonli $ABCD$ trapetsiyada A uchidan $AM = x$ masofada yotuvchi MN $\triangle PHB$ to'g'ri chiziq o'tkazilgan. $ABNMA$ figuraning S yuzasini x o'zgaruvchining funksiyasi sifatida ifodalang. $S = S(x)$ funk-tsiyaning grafigini yasang (2-rasm).

174. Ox o'qining $0 \leq x \leq 1$ kesmasida 2 g li massa tekis taqsimlangan, bu o'qning $x = 2$ va $x = 3$ nuqtalarida esa 1 g li massalar joylashtirilgan. Son jihatdan massaga teng bo'lgan va $(-\infty, x)$ oraliqda yotuvchi $m = m(x)$ ($-\infty < x < +\infty$) funksiyaning analitik ifoda-sini toping. Bu funksiyaning grafigini yasang.

175. $y = \operatorname{sgn} x$ funksiya quyidagicha aniqlanadi:

$$\operatorname{sgn} x = \begin{cases} -1, & \text{agap } x < 0 \\ 0, & \text{agap } x = 0 \\ 1, & \text{agap } x > 0 \end{cases}$$

Bu funksiyaning grafigini yasang. $|x| = x \operatorname{sgn} x$ ekanligini ko'rsating.

176. $y = [x]$ (x sonning butun qismi) funksiya quyidagicha aniqlanadi: agar $x = n + r$ bo'lsa, u holda $[x] = n$, bunda n - butun son va $0 \leq r < 1$.

SHu funksiyaning grafigini yasang.

177. $y = p(x)$ ($x \geq 0$) - x sonda katta bo'lmagan tub sonlarning sonini ifodalovchi funksiya. Argumentning $0 \leq x \leq 20$ qiymatlari uchun bu funksiyaning grafigini yasang.

Quyidagi $y = f(x)$ funksiya E_x to'plamni qanday E_y to'plamga akslantiradi (178-182):

178. $y = x^2$, $E_x = \{-1 \leq x \leq 2\}$.

179. $y = \lg x$, $E_x = \{10 < x < 1000\}$.

180. $y = \frac{1}{p} \operatorname{arctg} x$, $E_x = \{-\infty < x < +\infty\}$.

181. $y = \operatorname{ctg} \frac{px}{4}$, $E_x = \{0 < |x| \leq 1\}$.

182. $y = |x|$, $E_x = \{1 \leq |x| \leq 2\}$.

Agar x o'zgaruvchi $0 < x < 1$ oraliqda joylashgan bo'lsa, y o'zgaruvchi qanday oraliqda joylashgan (183-188):

183. $y = a + (b - a)x$.

184. $y = \frac{1}{1 - x}$.

185. $y = \frac{x}{2x - 1}$.

186. $y = \sqrt{x - x^2}$.

187. $y = \operatorname{ctg} px$.

188. $y = x + [2x]$.

189. Agar $f(x) = x^4 - 6x^3 + 11x^2 - 6x$ bo'lsa, $f(0)$, $f(1)$, $f(2)$, $f(3)$, $f(4)$ larni toping.

190. Agar $f(x) = \lg(x^2)$ bo'lsa, $f(-1)$, $f(-0,001)$, $f(100)$ larni toping.

191. Agar $f(x) = 1 + [x]$ bo'lsa, $f(0,9)$, $f(0,99)$, $f(0,999)$, $f(1)$ larni toping.

192. Agar

$$f(x) = \begin{cases} 1 + x, & \text{agar } -\infty < x \leq 0, \\ 2^x, & \text{agar } 0 < x < +\infty \end{cases}$$

bo'lsa, $f(-2)$, $f(-1)$, $f(0)$, $f(1)$, $f(2)$ larni toping.

193. Agar $f(x) = \frac{1-x}{1+x}$ bo'lsa, $f(0)$, $f(-x)$, $f(x+1)$, $f(x)+1$, $f\left(\frac{1}{x}\right)$, $\frac{1}{f(x)}$ larni toping.

194. Agar

a) $f(x) = x - x^3$;

b) $f(x) = \sin \frac{p}{x}$;

v) $f(x) = (x + |x|)(1 - x)$

bo'lsa, x ning 1) $f(x) = 0$; 2) $f(x) > 0$; 3) $f(x) < 0$ shartni qanoatlantiruvchi qiymatlarini toping.

195. Agar

a) $f(x) = ax + b$;

b) $f(x) = x^2$;

v) $f(x) = a^x$

bo'lsa, $j(x) = \frac{f(x+h) - f(x)}{h}$ ni toping.

196. $f(x) = ax^2 + bx + c$ bo'lsin. Isbotlang: $f(x+3) - 3f(x+2) + 3f(x+1) - f(x) = 0$.

197. Agar $f(0) = -2$, $f(3) = 5$ bo'lsa, $f(x) = ax + b$ chiziqli butun funksiyani toping. $f(1)$, $f(2)$ lar nimaga teng (chiziqli interpolatsiya)?

198. Agar $f(-2) = 0$, $f(0) = 1$, $f(1) = 5$ bo'lsa, ikkinchi darajali $f(x) = ax^2 + bx + c$ butun ratsional funksiyani toping.

$f(-1)$, $f(0,5)$ lar nimaga teng (kvadratik interpolatsiya)?

199. Agar $f(-1) = 0$, $f(0) = 2$, $f(1) = -3$, $f(2) = 5$ bo'lsa, u holda uchinchi darajali $f(x) = ax^3 + bx^2 + cx + d$ butun ratsional funksiyani toping.

200. Agar $f(0) = 15$, $f(2) = 30$, $f(4) = 90$ bo'lsa, u holda $f(x) = a + bc^x$ ko'rinishdagi funksiyani toping.

221. Quyidagi funksiyalarni monotonlikka tekshiring:

a) $f(x) = ax + b$; b) $f(x) = ax^2 + bx + c$; v) $f(x) = x^3$;

g) $f(x) = \frac{ax+b}{cx+d}$; d) $f(x) = a^x \quad (a > 0)$.

222. Tengsizlikni hadma-had logarifmlash mumkinmi?

223. $j(x)$, $y(x)$ va $f(x)$ - monoton o'suvchi funksiyalar bo'lsin. Agar

$$j(x) \leq f(x) \leq y(x)$$

bo'lsa, u holda

$$j[j(x)] \leq f[f(x)] \leq y[y(x)]$$

ekanligini isbotlang.

Quyidagi funksiyalarga teskari funksiyalarni va ularning aniqlanish sohasini toping (224-230):

224. $y = 2x + 3 \quad (-\infty < x < +\infty)$.

225. $y = x^2$ a) $-\infty < x \leq 0$; b) $0 \leq x < +\infty$.

226. $y = \frac{1-x}{1+x} \quad (x \neq -1)$.

227. $y = \sqrt{1-x^2}$ a) $-1 \leq x \leq 0$; b) $0 \leq x \leq 1$.

228. $y = shx$, bunda $shx = \frac{1}{2}(e^x - e^{-x}) \quad (-\infty < x < +\infty)$.

229. $y = thx$, bunda $thx = \frac{e^x - e^{-x}}{e^x + e^{-x}} \quad (-\infty < x < +\infty)$.

230.

$$y = \begin{cases} x, & \text{agap} \quad -\infty < x < 1; \\ x^2, & \text{agap} \quad 1 \leq x \leq 4; \\ 2^x, & \text{agap} \quad 4 < x < +\infty. \end{cases}$$

231. Agar simmetrik $(-l, l)$ oraliqda aniqlangan $f(x)$ funksiya uchun $f(-x) \equiv f(x)$ bo'lsa, u holda funksiya juft, $f(-x) \equiv -f(x)$ bo'lsa esa funksiya toq funksiya deyiladi.

Berilgan $f(x)$ funksiyalarning qaysilari juft, qaysilari toqligini aniqlang:

a) $f(x) = 3x - x^3$; b) $f(x) = \sqrt[3]{(1-x)^2} + \sqrt[3]{(1+x)^2}$; v) $f(x) = a^x + a^{-x} \quad (a > 0)$;

g) $f(x) = \ln \frac{1-x}{1+x}$; d) $f(x) = \ln(x + \sqrt{1+x^2})$.

232. Simmetrik $(-l, l)$ oraliqda aniqlangan ixtiyoriy $f(x)$ funksiyani juft va toq funksiyalarning yig'indisi ko'rinishda ifodalash mumkinligini isbotlang.

233. Agar E to'plamda aniqlangan $f(x)$ funksiya uchun

$$f(x \pm T) = f(x), \quad x \in E$$

shart bajariladigan funksiyaning davri deb atalmish $T > 0$ son mavjud bo'lsa, u holda $f(x)$ funksiya davriy deyiladi.

Quyidagi funksiyalarning qaysilari davriy ekanligini aniqlang va ularning eng kichik davrini toping:

a) $f(x) = A \cos lx + B \sin lx$; b) $f(x) = \sin x + \frac{1}{2} \sin 2x + \frac{1}{3} \sin 3x$;

v) $f(x) = 2tg \frac{x}{2} - 3tg \frac{x}{3}$; g) $f(x) = \sin^2 x$; d) $f(x) = \sin x^2$;

e) $f(x) = \sqrt{tgx}$; j) $f(x) = tg \sqrt{x}$; z) $f(x) = \sin x + \sin(x\sqrt{2})$.

234. Ushbu

$$c(x) = \begin{cases} 1, & \text{agar } x \text{ ratsional b'ulsa,} \\ 0, & \text{agar } x \text{ irratsional b'ulsa.} \end{cases}$$

Dirixle funksiyasi uchun ixtiyoriy ratsional son davr bo`lishini isbotlang.

235. Davrlari o`lchovdash va aniqlanish sohasi umumiy bo`lgan ikki davriy funksiyalarning yig`indisi va ko`paytmasi ham davriy1 funksiya bo`lishini isbotlang.

235.1. Agar $f(x)$ funksiya uchun

$$f(x+T) \equiv -f(x), \quad (T > 0)$$

shart bajarilsa, $f(x)$ funksiya antidavriy deyiladi. $f(x)$ funksiya davriy va uning davri $2T$ ga teng ekanligini isbotlang.

236. Agar $f(x)$ ($-\infty < x < +\infty$) funksiya uchun $f(x+T) = kf(x)$ shart bajarilsa, bunda k va T - musbat o`zgarmas sonlar, u holda

$$f(x) = a^x j(x)$$

bo`ladi, bunda a - o`zgarmas son, $j(x)$ - davri T bo`lgan davriy funksiya.

4. Funksiya grafigi

237. Bir jinsli $y = ax$ chiziqli funksiya grafigini $a = 0; \frac{1}{2}; 1; 2; -1$ bo'lganda yasang.

238. $y = x + b$ chiziqli funksiya grafigini $b = 0; 1; 2; -1$ bo'lganda yasang.

239. Quyidagi chiziqli funksiyalarning grafigini yasang:

a) $y = 2x + 3;$

b) $y = 2 - 0,1x;$

v) $y = -\frac{x}{2} - 1.$

240. Temirning chiziqli kengayishining harorat koeffitsienti $a = 1,2 \cdot 10^{-6}$ ga teng. Mos masshtabda ushbu

$$l = f(T) \quad (-40^\circ \leq T \leq 100^\circ)$$

funksiyaning grafigini yasang, bunda T – gradus o'lchovidagi harorat va l – temir sterjenning T haroratdagi uzunligi, agar $l = f(0^\circ) = 100$ sm bo'lsa.

241. Sonlar o'qida ikkita material nuqtalar harakatlanmoqda. Birinchi nuqta $t = 0$ vaqtda koordinatalar boshidan chap tomonda 20 m masofada joylashgan bo'lib, $v_1 = 10$ m/s tezlikka ega; ikkinchisi esa $t = 0$ vaqtda koordinatalar boshidan o'ng tomonda 30 m masofada joylashgan bo'lib, $v_2 = -20$ m/s tezlikka ega edi. Bu nuqtalar harakat tenglamalarining grafiklarini yasang va ularning uchrashish vaqti va joyini aniqlang.

242. Quyidagi ikkinchi darajali butun ratsional funksiyalarning grafiklarini yasang (parabolalar):

a) $y = ax^2$ $a = 1, 1/2, 2, -1$ bo'lganda;

b) $y = (x - x_0)^2$ $x_0 = 0, 1, 2, -1$ bo'lganda;

v) $y = x^2 + c$ $c = 0, 1, 2, -1$ bo'lganda.

243. $y = ax^2 + bc + c$ kvadrat ko'phadni

$$y = y_0 + a(x - x_0)^2$$

ko'rinishga keltirib, uning grafigini yasang.

Misollar ko'ring:

a) $y = 8x - 2x^2;$ b) $y = x^2 - 3x + 2;$ v) $y = -x^2 + 2x - 1;$ g) $y = \frac{1}{2}x^2 + x + 1.$

244. Material nuqta gorizont tekisligiga $a = 45^\circ$ burchak ostida $v_0 = 600$ m/s boshlang'ich tezlik bilan tashlab yuborildi. Harakat traektoriyasi grafigini yasang va yuqoriga ko'tarilishning eng katta balandligi hamda uchish masofasini toping ($g \approx 10$ m/c² deb oling, havo qarishiligi hisobga olinmaydi).

Quyidagi darajasi ikkidan yuqori bo'lgan butun ratsional funksiyalarning grafiklarini yasang (245-248):

245. $y = x^3 + 1.$

246. $y = (1 - x^2)(2 + x).$

247. $y = x^2 - x^4.$

248. $y = x(a - x)^2 (a + x)^3$ ($a > 0$).

Quyidagi kasr-chiziqli funksiyalarning grafiklarini yasang (giperbolalar, 249-250):

249. $y = \frac{1}{x}.$

250. $y = \frac{1 - x}{1 + x}.$

251. $y = \frac{ax + b}{cx + d}$ ($ad - bc \neq 0, c \neq 0$) kasr-chiziqli funksiyani

$$y = y_0 + \frac{m}{x - x_0}$$

ko'rinishga keltirib grafigini yasang.

Misol ko`ring: $y = \frac{3x+2}{2x-3}$.

252. Gaz $p_0 = 1$ kgs/m² bosim bilan $v_0 = 12$ m³ hajmi egallaydi. Agar gazning harorati o`zgarmasa, u holda p bosimga bog`liq bo`lgan gaz hajmi v o`zgarishining grafigini yasang (Boyl'-Mariott qonuni).

Quyidagi kasr ratsional funksiyalarning grafiglarini yasang (253-262):

253. $y = x + \frac{1}{x}$ (giperbola).

254. $y = x^2 + \frac{1}{x}$ (N'yuton uchtishi).

255. $y = x + \frac{1}{x^2}$.

256. $y = \frac{1}{1+x^2}$ (An'ezi chizig`i).

257. $y = \frac{2x}{1+x^2}$ (N'yuton serpantini).

258. $y = \frac{1}{1-x^2}$.

259. $y = \frac{x}{1-x^2}$.

260. $y = \frac{1}{1+x} - \frac{2}{x} + \frac{1}{1-x}$.

261. $y = \frac{1}{1+x} - \frac{2}{x^2} + \frac{1}{1-x}$.

262. $y = \frac{(x+1)(x-2)}{(x-1)(x+2)}$.

263. Ushbu

$$y = \frac{ax^2 + bx + c}{a_1x + b_1} \quad (a_1 \neq 0)$$

funksiyani

$$y = kx + m + \frac{n}{x - x_0}$$

ko`rinishga keltirib grafigini yasang.

Misol ko`ring: $y = \frac{x^2 - 4x + 3}{x + 1}$.

264. Tortib turuvchi markazdan x masofada joylashgan material nuqtaning F tortishish kuchi modulining grafigini yasang, bunda $x = 1$ m bo`lganda $F = 10$ kgs ga teng (N'yuton qonuni).

265. Van-der-Vaal's qonuniga ko`ra real gazning v hajmi va p bosimi o`zgarmas haroratda ushbu

$$\left(p + \frac{a}{v^2}\right)(v - b) = c$$

munosabat bilan bog`langan. Agar $a = 2$, $b = 0,1$ va $c = 10$ bo`lsa, u holda $p = p(v)$ funksiyaning grafigini yasang.

Quyidagi irratsional funksiyalarning grafiglarini yasang (266-273):

266. $y = \pm\sqrt{-x-2}$ (parabola).

267. $y = \pm x\sqrt{x}$ (Neyl parabolasi).

268. $y = \pm \frac{1}{2}\sqrt{100-x^2}$ (ellips).

269. $y = \pm\sqrt{x^2-1}$ (giperbola).

270. $y = \pm\sqrt{\frac{1-x}{1+x}}$.

271. $y = \pm x\sqrt{100-x^2}$.

272. $y = \pm x\sqrt{\frac{x}{10-x}}$ (tsissoida).

273. $y = \pm\sqrt{(x^2-1)(9-x^2)}$.

274. $y = x^n$ darajali funksiyaning grafigini n ning quyidagi qiymatlarida yasang:

a) $n = 1, 3, 5$;

b) $n = 2, 4, 6$.

275. $y = x^n$ darajali funksiyaning grafigini n ning quyidagi qiymatlarida yasang:

$$306. y = \pm 2^{-x} \sqrt{\sin p x}.$$

$$307. y = \frac{\cos x}{1+x^2}.$$

$$308. y = \ln(\cos x).$$

$$309. y = \cos(\ln x).$$

$$310. y = e^{\frac{1}{\sin x}}.$$

Teskari doiraviy funksiyalarning grafiklarini yasang (311-322):

$$311. y = \arcsin x.$$

$$312. y = \arccos x.$$

$$313. y = \operatorname{arctg} x.$$

$$314. y = \operatorname{arcctg} x.$$

$$315. y = \arcsin \frac{1}{x}.$$

$$316. y = \arccos \frac{1}{x}.$$

$$317. y = \operatorname{arcctg} \frac{1}{x}.$$

$$318. y = \arcsin(\sin x).$$

$$319. y = \arcsin(\cos x).$$

$$320. y = \arccos(\cos x).$$

$$321. y = \operatorname{arctg}(\operatorname{tg} x).$$

$$322. y = \arcsin(2 \sin x).$$

323. Agar:

$$a) y_1 = 1 - \frac{x}{2};$$

$$b) y_1 = \frac{2x}{1+x^2};$$

$$v) y_1 = \frac{1-x}{1+x};$$

$$g) y_1 = e^x$$

bo`lsa, $y = \arcsin y_1$ funksiyaning grafigini yasang.

324. Agar:

$$a) y_1 = x^2;$$

$$b) y_1 = \frac{1}{x^2};$$

$$v) y_1 = \ln x;$$

$$g) y_1 = \frac{1}{\sin x}$$

bo`lsa, $y = \operatorname{arctg} y_1$ funksiyaning grafigini yasang.

324.1. Funksiyalarning grafiklarini yasang:

$$a) y = x^3 - 3x + 2;$$

$$b) y = \frac{x^3}{(1-x)(1+x)^2};$$

$$v) y = \frac{x^2}{|x|-1};$$

$$g) y = \sqrt{x(1-x^2)};$$

$$d) y = 3 \sin\left(\frac{x}{2} + \frac{p}{4}\right);$$

$$e) y = \operatorname{ctg} \frac{px}{1+x^2};$$

$$j) y = \frac{1}{1-2^{x/1-x}};$$

$$z) y = \lg(x^2 - 3x + 2);$$

$$i) y = \arcsin\left(\frac{3}{2} - \sin x\right);$$

$$k) y = \operatorname{arctg}\left(\frac{1}{x-1} + \frac{1}{x-2} + \frac{1}{x-3}\right);$$

$$l) y = \log_{\cos x} \sin x$$

$$m) y = (\sin x)^{\operatorname{ctg} x}.$$

325. $y = f(x)$ funksiya grafigini bilgan holda quyidagi funksiyalarning grafiklarini yasang:

$$a) y = -f(x);$$

$$b) y = f(-x);$$

$$v) y = -f(-x).$$

326. $y = f(x)$ funksiya grafigini bilgan holda quyidagi funksiyalarning grafiklarini yasang:

$$a) y = f(x-x_0); \quad b) y = y_0 + f(x-x_0); \quad v) y = f(2x); \quad g) y = f(kx+b) \quad (k \neq 0).$$

326.1. Ushbu

$$f(x) = \begin{cases} 1-|x|, & |x| \leq 1; \\ 0, & |x| > 1 \end{cases}$$

funksiya berilgan. $t = 0, t = 1, t = 2$ bo`lganda quyidagi funksiyaning grafigini yasang:

$$y = \frac{1}{2}[f(x-t) + f(x+t)].$$

327. Funksiyalarning grafiklarini yasang:

$$a) y = 2 + \sqrt{1-x};$$

$$b) y = 1 - e^{-x};$$

$$v) y = \ln(1+x);$$

g) $y = -\arcsin(1+x)$; d) $y = 3 + 2 \cos 3x$.

328. $y = f(x)$ funksiya grafigini bilgan holda quyidagi funksiyalarning grafik-larini yasang:

a) $y = |f(x)|$; b) $y = \frac{1}{2}(|f(x)| + f(x))$; v) $y = \frac{1}{2}(|f(x)| - f(x))$.

329. $y = f(x)$ funksiya grafigini bilgan holda quyidagi funksiyalarning grafik-larini yasang:

a) $y = f^2(x)$; b) $y = \sqrt{f(x)}$; v) $y = \ln f(x)$;
g) $y = f(f(x))$; d) $y = \operatorname{sgn} f(x)$; e) $y = [f(x)]$.

329.1. $f(x) = (x-a)(b-x)$ ($a < b$) funksiya berilgan. Quyidagi funksiyalarning grafiklarini yasang:

a) $y = f(x)$; b) $y = f^2(x)$; v) $y = \frac{1}{f(x)}$; g) $y = \sqrt{f(x)}$;
d) $y = e^{f(x)}$; e) $y = \lg f(x)$; j) $y = \operatorname{arctg} f(x)$.

329.2. Agar 1) $f(x) = x^2$; 2) $f(x) = x^3$ bo`lsa, funksiyalarning grafiklarini yasang:

a) $y = \arcsin[\sin f(x)]$; b) $y = \arcsin[\cos f(x)]$; v) $y = \arccos[\sin f(x)]$;
g) $y = \arccos[\cos f(x)]$; d) $y = \operatorname{arctg}[tg f(x)]$.

330. $y = f(x)$ va $y = g(x)$ funksiyalarning grafiklarini bilgan holda quyidagi funksiyalarning grafiklarini yasang:

a) $y = f(x) + g(x)$; b) $y = f(x)g(x)$; v) $y = f(g(x))$.

Grafiklarini qo`shish qoidasidan foydalanib, quyidagi funksiyalarning grafiklarini yasang (331-339):

331. $y = 1 + x + e^x$. 332. $y = (x+1)^{-2} + (x-1)^{-2}$.
333. $y = x + \sin x$. 334. $y = x + \operatorname{arctg} x$.
335. $y = \cos x + \frac{1}{2} \cos 2x + \frac{1}{3} \cos 3x$. 336. $y = \sin x - \frac{1}{3} \sin 3x + \frac{1}{5} \cos 5x$.
337. $y = \sin^4 x + \cos^4 x$. 338. $y = |1-x| + |1+x|$.

339. $y = |1-x| - |1+x|$.

340. Giperbolik funksiyalarning grafiklarini yasang:

a) $y = ch x$, bunda $ch x = \frac{1}{2}(e^x + e^{-x})$; b) $y = sh x$, bunda $sh x = \frac{1}{2}(e^x - e^{-x})$;
v) $y = th x$, bunda $th x = \frac{sh x}{ch x}$.

Grafiklarni ko`paytirish qoidasidan foydalanib, quyidagi funksiyalarning grafiklarini yasang (341-348):

341. $y = x \sin x$. 342. $y = x \cos x$.
343. $y = x^2 \sin^2 x$. 344. $y = \frac{\sin x}{1+x^2}$.
345. $y = e^{-x^2} \cos 2x$. 346. $y = x \operatorname{sgn}(\sin x)$.
347. $y = [x] |\sin p x|$. 348. $y = \cos x \cdot \operatorname{sgn}(\sin x)$.

349. Ushbu

$$f(x) = \begin{cases} 1-|x|, & |x| \leq 1; \\ 0, & |x| > 1 \end{cases}$$

funksiya berilgan. Agar a) $a = 0$; b) $a = 1$; v) $a = 2$ bo'lsa, u holda ushbu

$$y = f(x)f(a-x)$$

funksiyaning grafigini yasang.

350. Funksiyaning grafigini yasang: $y = x + \sqrt{x} \operatorname{sgn}(\sin px)$.

$y = \frac{1}{f(x)}$ funksiyaning grafigini yasang (351-355):

351. $f(x) = x^2(1-x^2)$.

352. $f(x) = x(1-x)^2$.

353. $f(x) = \sin^2 x$.

354. $f(x) = \ln x$.

355. $f(x) = e^x \sin x$.

356. Agar

$$f(u) = \begin{cases} -1, & -\infty < u < -1; \\ u, & -1 \leq u \leq 1; \\ 1, & 1 < u < +\infty \end{cases}$$

bo'lsa, u holda $y = f(u)$ murakkab funksiya grafigini yasang, bunda $u = 2 \sin x$.

357. Agar

$$j(x) = \frac{1}{2}(x+|x|) \text{ va } y(x) = \begin{cases} x, & x < 0; \\ x^2, & x \geq 0 \end{cases}$$

bo'lsa, u holda quyidagi funksiyalarning grafiglarini yasang:

a) $y = j[j(x)]$; b) $y = j[y(x)]$; v) $y = y[j(x)]$; g) $y = y[y(x)]$.

358. Agar

$$j(x) = \begin{cases} 1, & |x| \leq 1; \\ 0, & |x| > 1 \end{cases} \text{ va } y(x) = \begin{cases} 2-x^2, & |x| \leq 2; \\ 2, & |x| > 2 \end{cases}$$

bo'lsa, u holda quyidagi funksiyalarning grafiglarini yasang:

a) $y = j[j(x)]$; b) $y = j[y(x)]$; v) $y = y[j(x)]$; g) $y = y[y(x)]$.

359. Agar:

a) $f(x) = 1-x$; b) $f(x) = 2x-x^2$; v) $f(x) = \sqrt{x}$;

g) $f(x) = \sin x$; d) $f(x) = e^x$; e) $f(x) = \ln x$

bo'lsa, u holda $x > 0$ musbat sohada aniqlangan $f(x)$ funksiyani $x < 0$ manfiy sohaga shunday davom ettiringki, hosil bo'lgan funksiya: 1) juft; 2) toq bo'lsin.

Funksiyalarning mos grafiglarini yasang.

360. Quyidagi funksiyalarning grafiglari qaysi vertikal o'qqa nisbatan simmetrik ekanligini aniqlang:

a) $y = ax^2 + bx + c$;

b) $y = \frac{1}{x^2} + \frac{1}{(1-x)^2}$;

v) $y = \sqrt{a+x} + \sqrt{b-x}$ ($0 < a < b$);

g) $y = a + b \cos x$.

361. Quyidagi funksiyalarning grafiglari qanday markazlarga nisbatan simmetrik ekanligini aniqlang:

a) $y = ax + b$;

b) $y = \frac{ax+b}{cx+d}$;

v) $y = ax^3 + bx^2 + cx + d$;

$$g) y = \frac{1}{x-1} + \frac{1}{x-2} + \frac{1}{x-3}; \quad d) y = 1 + \sqrt[3]{x-2}.$$

362. Davriy funksiyalarning grafiklarini yasang:

$$a) y = |\sin x|; \quad b) y = \operatorname{sgn} \cos x;$$

$$v) y = f(x), \text{ bunda agar } 0 \leq x \leq 2l \text{ bo'lsa, } f(x) = A \frac{x}{l} \left(2 - \frac{x}{l} \right) \text{ va } f(x+2l) \equiv f(x);$$

$$g) y = [x] - 2 \left[\frac{x}{2} \right]; \quad d) y = (x), \text{ bunda } (x) - x \text{ sondan unga eng yaqin butun}$$

songacha bo'lgan masofa.

363. Agar $y = f(x)$ ($-\infty < x < +\infty$) funksiyaning grafigi ikki $x = a$ va $x = b$ ($b > a$) vertikal o'qlarga nisbatan simmetrik bo'lsa, u holda bu funksiya davriy ekanligini isbotlang.

364. Agar $y = f(x)$ ($-\infty < x < +\infty$) funksiyaning grafigi ikki $A(a, y_0)$ va $B(b, y_1)$ ($b > a$) nuqtalarga nisbatan simmetrik bo'lsa, u holda bu funksiya chiziqli va davriy funksiyalarning yig'indisidan iborat ekanligini isbotlang. Xususan, agar $y_0 = y_1$ bo'lsa, $f(x)$ -davriy.

365. Agar $y = f(x)$ ($-\infty < x < +\infty$) funksiyaning grafigi $A(a, y_0)$ nuqta va $x = b$ ($b \neq a$) to'g'ri chiziqqa nisbatan simmetrik bo'lsa, u holda bu funksiya davriy ekanligini isbotlang.

366. Agar $f(x+1) = 2f(x)$ va $0 \leq x \leq 1$ da $f(x) = x(1-x)$ bo'lsa, u holda $y = f(x)$ ($-\infty < x < +\infty$) funksiyaning grafigini yasang.

367. Agar $f(x+p) = f(x) + \sin x$ va $0 \leq x \leq p$ da $f(x) = 0$ bo'lsa, u holda $y = f(x)$ ($-\infty < x < +\infty$) funksiyaning grafigini yasang.

368. Agar:

$$a) x = y - y^3; \quad b) x = \frac{1-y}{1+y}; \quad v) x = y - \ln y; \quad g) x^2 = \sin y$$

bo'lsa, $y = y(x)$ funksiyaning grafigini yasang.

369. Agar:

$$a) x = 1-t, \quad y = 1-y^2; \quad b) x = t + \frac{1}{t}, \quad y = t + \frac{1}{t^2};$$

$$v) x = 10 \cos t, \quad y = \sin t \text{ (ellips);} \quad g) x = cht, \quad y = sh t \text{ (giperbola);}$$

$$d) x = 5 \cos^2 t, \quad y = 3 \cos^2 t; \quad e) x = 2(t - \sin t), \quad y = 2(1 - \cos t) \text{ (tsikloida);}$$

$$j) x = \sqrt[t]{t}, \quad y = \sqrt[t]{t+1} \quad (t > 0)$$

bo'lsa, $y = y(x)$ funksiyaning grafigini yasang.

370. Oshkormas funksiyalarning grafiklarini yasang:

$$a) x^2 - xy + y^2 = 1 \text{ (ellips);} \quad b) x^3 + y^3 - 3xy = 0 \text{ (dekart yaprog'i);}$$

$$v) \sqrt{x} + \sqrt{y} = 1 \text{ (parabola);} \quad g) x^{2/3} + y^{2/3} = 4 \text{ (astroida);}$$

$$d) \sin x = \sin y; \quad e) \cos(px^2) = \cos(py);$$

$$j) x^y = y^x \quad (x > 0, y > 0); \quad z) x - |x| = y - |y|.$$

370.1. Oshkormas funksiyalarning grafiklarini yasang:

$$a) \min(x, y) = 1; \quad b) \max(x, y) = 1; \quad v) \max(|x|, |y|) = 1; \quad g) \min(x^2, y) = 1.$$

371. Quyidagi $r = r(j)$ funksiyalar grafiklarini (r, j) qutb koordinatalar sistemasida yasang:

- a) $r = j$ (Arximed spirali); b) $r = \frac{p}{j}$ (giperbolik spiral');
 v) $r = \frac{j}{j+1}$ ($0 \leq j < +\infty$); g) $r = 2^{j/2p}$ (logarifmik spiral');
 d) $r = 2(1 + \cos j)$ (kardilida); e) $r = 10 \sin 3j$ (uch yaproqli gul);
 j) $r^2 = 36 \cos 2j$ (Bernulli lemniskatasi);
 z) $j = \frac{r}{r-1}$ ($r > 1$); i) $j = 2p \sin r$.

371.1. Quyidagi funksiyalar grafiklarini r va j qutb koordinatalar sistemasida yasang:

- a) $j = 4r - r^2$; b) $j = \frac{12r}{1+r^2}$; v) $r^2 + j^2 = 100$.

371.2. Parametrik ko`rinishda berilgan quyidagi funksiyalar grafiklarini r va j qutb koordinatalar sistemasida yasang:

- a) $\left. \begin{aligned} j &= t \cos^2 t, \\ r &= t \sin^2 t, \end{aligned} \right\};$ b) $\left. \begin{aligned} j &= 1 - 2^{-t} \sin \frac{pt}{2}, \\ r &= 1 - 2^{-t} \cos \frac{pr}{2}. \end{aligned} \right\}$

372. $y = x^3 - 3x + 1$ funksiyaning grafigini qurib, quyidagi tenglamani taqribiy eching:

$$x^3 - 3x + 1 = 0.$$

Quyidagi tenglamalarni grafik usulda eching (373-378):

373. $x^3 - 4x - 1 = 0$. 374. $x^4 - 4x + 1 = 0$.
 375. $x = 2^{-x}$. 376. $\lg x = 0,1x$.
 377. $10^x = x^2$. 378. $\lg x = x$ ($0 \leq x \leq 2p$).

Tenglamalar sistemasini grafik usulda eching (379-380):

379. $x + y^2 = 1, 16x^2 + y = 4$. 380. $x^2 + y^2 = 100, y = 10(x^2 - x - 2)$.

5. Funksiya limiti

381. Funksiya quyidagicha berilgan: agar $x = \frac{m}{n}$ bo'lsa, $f(x) = n$, bunda m va n – o'zaro tub butun sonlar, $n > 0$ va agar x irratsional son bo'lsa, $f(x) = 0$. Bu funksiya chekli, lekin har qanday x nuqtada chegaralanmaganligini isbotlang (ya'ni shu nuqtaning ixtiyoriy atrofida chegaralanmagan).

382. Agar $f(x)$ funksiya: a) intervalda, b) kesmada aniqlangan va lokal chegaralangan bo'lsa, u holda bu funksiya berilgan intervalda yoki mos ravishda kesmada chegaralangan bo'ladimi?

Misollar keltiring.

383. Ushbu

$$f(x) = \frac{1+x^2}{1+x^4}$$

funksiya $-\infty < x < +\infty$ intervalda chegaralangan ekanligini isbotlang.

384. Ushbu

$$f(x) = \frac{1}{x} \cos \frac{1}{x}$$

funksiya $x=0$ nuqtaning ixtiyoriy atrofida chegaralanmagan, ammo $x \rightarrow 0$ da cheksiz katta emasligini isbotlang.

385. $0 < x < e$ intervalda quyidagi funktsiyani chegaralanganlikka tekshiring:

$$f(x) = \ln x \sin^2 \frac{p}{x}.$$

386. Ushbu

$$f(x) = \frac{x}{1+x}$$

funksiya $0 \leq x < +\infty$ sohada $m=0$ ga teng aniq quyi chegaraga va $M=1$ ga teng aniq yuqori chegaraga ega ekanligini ko'rsating.

387. $f(x)$ funksiya $[a, b]$ kesmada aniqlangan va monoton o'suvchi. Bu kesmada funktsiyaning aniq quyi va aniq yuqori chegaralari nimaga teng?

Funksiyalarning ko'rsatilgan oraliqlarda aniq quyi va aniq yuqori chegaralarini aniqlang (388-396):

388. $f(x) = x^2, [-2, 5).$

389. $f(x) = \frac{1}{1+x^2}, (-\infty, +\infty).$

390. $f(x) = \frac{2x}{1+x^2}, (0, +\infty).$

391. $f(x) = x + \frac{1}{x}, (0, +\infty).$

392. $f(x) = \sin x, (0, +\infty).$

393. $f(x) = \sin x + \cos x, [0, 2p].$

394. $f(x) = 2^x, (-1, 2).$

395. $f(x) = [x]:$ a) $(0, 2)$, b) $[0, 2].$

396. $f(x) = x - [x], [0, 1].$

397. $f(x) = x^2$ funktsiyaning quyidagi intervallardagi tebranishini aniqlang:

a) $(1; 3)$; b) $(1,9; 2,1)$; v) $(1,99; 2,01)$; g) $(1,999; 2,001)$.

398. $f(x) = \arctg \frac{1}{x}$ funktsiyaning quyidagi intervallardagi tebranishini aniqlang:

a) $(-1; 1)$; b) $(-0,1; 0,1)$; v) $(-0,01; 0,01)$; g) $(-0,001; 0,001)$.

399. $m[f]$ va $M[f]$ - mos ravishda $f(x)$ funktsiyaning (a, b) intervaldagi aniq quyi va aniq yuqori chegaralari bo'lsin.

Agar $f_1(x)$ va $f_2(x) - (a, b)$ oraliqda aniqlangan funksiyalar bo'lsa, u holda quyidagi tengsizliklarni isbotlang:

$$m[f_1 + f_2] \geq m[f_1] + m[f_2] \quad \text{va} \quad M[f_1 + f_2] \leq M[f_1] + M[f_2].$$

Oxirgi munosabatlarda: a) tenglik, b) tengsizlik bajariladigan $f_1(x)$ va $f_2(x)$ funksiyalarga misollar keltiring.

400. $f(x)$ funksiya $[a, +\infty)$ sohada aniqlangan va har bir $[a, b]$ kesmada chegaralangan funksiya hamda

$$m(x) = \inf_{a \leq x \leq x} f(x) \quad \text{va} \quad M(x) = \sup_{a \leq x \leq x} f(x)$$

bo'lsin. Agar:

a) $f(x) = \sin x$; b) $f(x) = \cos x$

bo'lsa, u holda $y = m(x)$ va $y = M(x)$ funksiyalarning grafiklarini yasang.

401. « $e - d$ » tilida quyidagi tenglikni isbotlang:

$$\lim_{x \rightarrow 2} x^2 = 4.$$

Jadvalni to'ldiring:

e	0,1	0,01	0,001	0,0001	...
d					

402. « $E - d$ » tilida quyidagi tenglikni isbotlang:

$$\lim_{x \rightarrow 1} \frac{1}{(1-x)^2} = +\infty.$$

Jadvalni to'ldiring:

E	10	100	1000	10000	...
d					

403. Quyidagi tasdiqlarni tengsizliklar orqali ifodalang:

a) $\lim_{x \rightarrow a} f(x) = b$; b) $\lim_{x \rightarrow a-0} f(x) = b$; v) $\lim_{x \rightarrow a+0} f(x) = b$.

Misollar keltiring.

Quyidagi tasdiqlarni tengsizliklar yordamida ifodalang va mos misollar keltiring (404-406):

404. a) $\lim_{x \rightarrow \infty} f(x) = b$; b) $\lim_{x \rightarrow -\infty} f(x) = b$; v) $\lim_{x \rightarrow +\infty} f(x) = b$.

405. a) $\lim_{x \rightarrow a} f(x) = \infty$; b) $\lim_{x \rightarrow a} f(x) = -\infty$; v) $\lim_{x \rightarrow a} f(x) = +\infty$;

g) $\lim_{x \rightarrow a-0} f(x) = \infty$; d) $\lim_{x \rightarrow a-0} f(x) = -\infty$; e) $\lim_{x \rightarrow a-0} f(x) = +\infty$;

j) $\lim_{x \rightarrow a+0} f(x) = \infty$; z) $\lim_{x \rightarrow a+0} f(x) = -\infty$; i) $\lim_{x \rightarrow a+0} f(x) = +\infty$.

406. a) $\lim_{x \rightarrow \infty} f(x) = \infty$; b) $\lim_{x \rightarrow \infty} f(x) = -\infty$; v) $\lim_{x \rightarrow \infty} f(x) = +\infty$;

g) $\lim_{x \rightarrow -\infty} f(x) = \infty$; d) $\lim_{x \rightarrow -\infty} f(x) = -\infty$; e) $\lim_{x \rightarrow -\infty} f(x) = +\infty$;

j) $\lim_{x \rightarrow +\infty} f(x) = \infty$; z) $\lim_{x \rightarrow +\infty} f(x) = -\infty$; i) $\lim_{x \rightarrow +\infty} f(x) = +\infty$.

407. $y = f(x)$ bo'lsin. Quyidagilarning ma'nosini tengsizliklar orqali ifodalang va mos misollar ketiring:

a) $x \rightarrow a$ da $y \rightarrow b - 0$;

b) $x \rightarrow a - 0$ da $y \rightarrow b - 0$;

v) $x \rightarrow a + 0$ da $y \rightarrow b - 0$;

g) $x \rightarrow a$ da $y \rightarrow b + 0$;

d) $x \rightarrow a - 0$ da $y \rightarrow b + 0$;

e) $x \rightarrow a + 0$ da $y \rightarrow b + 0$;

j) $x \rightarrow \infty$ da $y \rightarrow b - 0$;

z) $x \rightarrow -\infty$ da $y \rightarrow b - 0$;

i) $x \rightarrow +\infty$ da $y \rightarrow b - 0$;

k) $x \rightarrow \infty$ da $y \rightarrow b + 0$;

l) $x \rightarrow -\infty$ da $y \rightarrow b + 0$;

m) $x \rightarrow +\infty$ da $y \rightarrow b + 0$.

408. Ushbu

$$P(x) = a_0x^n + a_1x^{n-1} + \dots + a_n$$

ko`phad uchun, bunda a_i ($i = 0, 1, \dots, n$) – haqiqiy sonlar, quyidagi tenglikni isbotlang:

$$\lim_{x \rightarrow \infty} |P(x)| = +\infty.$$

409. Ushbu

$$R(x) = \frac{a_0x^n + a_1x^{n-1} + \dots + a_n}{b_0x^n + b_1x^{n-1} + \dots + b_n}, \quad (a_0 \neq 0, b_0 \neq 0)$$

funksiya uchun quyidagi tenglikni isbotlang:

$$\lim_{x \rightarrow \infty} R(x) = \begin{cases} \infty, & \text{agar } n > m; \\ \frac{a_0}{b_0}, & \text{agar } n = m; \\ 0, & \text{agar } n < m. \end{cases}$$

410. Ushbu

$$R(x) = \frac{P(x)}{Q(x)}$$

funksiya berilgan, bunda $P(x)$ va $Q(x)$ – ko`phadlar va $P(a) = Q(a) = 0$ bo`lsin. U holda

$$\lim_{x \rightarrow a} \frac{P(x)}{Q(x)}$$

ifoda qanday qiymatlar qabul qilishi mumkin?

Quyidagi ifodalarning qiymatini toping (411-433):

411. a) $\lim_{x \rightarrow 0} \frac{x^2 - 1}{2x^2 - x - 1}$;

b) $\lim_{x \rightarrow 1} \frac{x^2 - 1}{2x^2 - x - 1}$;

v) $\lim_{x \rightarrow \infty} \frac{x^2 - 1}{2x^2 - x - 1}$.

412. $\lim_{x \rightarrow 0} \frac{(1+x)(1+2x)(1+3x) - 1}{x}$.

413. $\lim_{x \rightarrow 0} \frac{(1+x)^5 - (1+5x)}{x^2 + x^5}$.

414. $\lim_{x \rightarrow 0} \frac{(1+mx)^n - (1+nx)^m}{x^2}$ ($m, n \in \mathbb{N}$).

415. $\lim_{x \rightarrow \infty} \frac{(x-1)(x-2)(x-3)(x-4)(x-5)}{(5x-1)^5}$.

416. $\lim_{x \rightarrow \infty} \frac{(2x-3)^{20}(3x+2)^{30}}{(2x+1)^{50}}$.

417. $\lim_{x \rightarrow \infty} \frac{(x+1)(x^2+1)\dots(x^n+1)}{\left((nx)^n + 1\right)^{\frac{n+1}{2}}}$.

418. $\lim_{x \rightarrow 3} \frac{x^2 - 5x + 6}{x^2 - 8x + 15}$.

419. $\lim_{x \rightarrow 1} \frac{x^3 - 3x + 2}{x^4 - 4x + 3}$.

420. $\lim_{x \rightarrow 1} \frac{x^4 - 3x + 2}{x^5 - 4x + 3}$.

421. $\lim_{x \rightarrow 2} \frac{x^3 - 2x^2 - 4x + 8}{x^4 - 8x^2 + 16}$.

422. $\lim_{x \rightarrow 1} \frac{x^3 - 2x - 1}{x^5 - 2x - 1}$.

$$423. \lim_{x \rightarrow 2} \frac{(x^2 - x - 2)^{20}}{(x^3 - 12x + 16)^{10}}.$$

$$424. \lim_{x \rightarrow 1} \frac{x + x^2 + \dots + x^n - n}{x - 1}.$$

$$424.1. \lim_{x \rightarrow 1} \frac{x^{100} - 2x + 1}{x^{50} - 2x + 1}.$$

$$425. \lim_{x \rightarrow 1} \frac{x^m - 1}{x^n - 1} \quad (m, n \in \mathbb{N}).$$

$$426. \lim_{x \rightarrow a} \frac{(x^n - a^n) - na^{n-1}(x - a)}{(x - a)^2} \quad (n \in \mathbb{N}).$$

$$427. \lim_{x \rightarrow 1} \frac{x^{n+1} - (n+1)x + n}{(x-1)^2} \quad (n \in \mathbb{N}).$$

$$428. \lim_{x \rightarrow 1} \left(\frac{m}{1-x^m} - \frac{n}{1-x^n} \right) \quad (m, n \in \mathbb{N}).$$

$$429. \lim_{n \rightarrow \infty} \frac{1}{n} \left[\left(x + \frac{a}{n} \right) + \left(x + \frac{2a}{n} \right) + \dots + \left(x + \frac{(n-1)a}{n} \right) \right].$$

$$430. \lim_{n \rightarrow \infty} \frac{1}{n} \left[\left(x + \frac{a}{n} \right)^2 + \left(x + \frac{2a}{n} \right)^2 + \dots + \left(x + \frac{(n-1)a}{n} \right)^2 \right].$$

Y o`ll a n m a. 2-misolga qarang.

$$431. \lim_{n \rightarrow \infty} \frac{1^2 + 3^2 + \dots + (2n-1)^2}{2^2 + 4^2 + \dots + (2n)^2}.$$

$$432. \lim_{n \rightarrow \infty} \left(\frac{1^3 + 2^3 + \dots + n^3}{n^3} - \frac{n}{4} \right).$$

Y o`ll a n m a. 3-misolga qarang.

$$433. \lim_{n \rightarrow \infty} \frac{1^3 + 4^3 + 7^3 + \dots + (3n-2)^3}{(1+4+7+\dots+(3n-2))^2}.$$

434. $y = b \left(\frac{x}{a} \right)^2$ parabola, Ox o`qi va $x = a$ to`g`ri chiziqlar bilan chegaralangan egri

chiziqli OAM uchburchakning yuzini unga ichki chizilgan, asoslari $\frac{a}{n}$ ga teng to`g`ri to`rtburchaklar yuzalari yig`indisining limiti sifatida hisoblang, bunda $n \rightarrow \infty$.

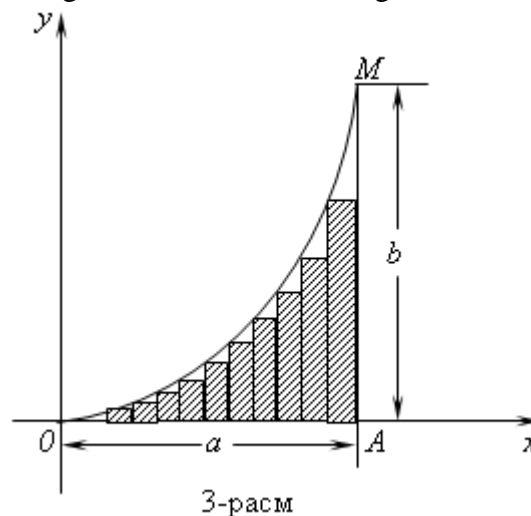

Limitlarni toping (435-453, 455-467):

$$435. \lim_{x \rightarrow +\infty} \frac{\sqrt{x + \sqrt{x + \sqrt{x}}}}{\sqrt{x+1}}.$$

$$436. \lim_{x \rightarrow +\infty} \frac{\sqrt{x} + \sqrt[3]{x} + \sqrt[4]{x}}{\sqrt{2x+1}}.$$

$$437. \lim_{x \rightarrow 4} \frac{\sqrt{1+2x}-3}{\sqrt{x}-2}.$$

$$439. \lim_{x \rightarrow a} \frac{\sqrt{x}-\sqrt{a}+\sqrt{x-a}}{\sqrt{x^2-a^2}} \quad (a > 0).$$

$$441. \lim_{x \rightarrow -2} \frac{\sqrt[3]{x-6}+2}{x^3+8}.$$

$$443. \lim_{x \rightarrow 8} \frac{\sqrt{9+2x}-5}{\sqrt[3]{x}-2}.$$

$$445. \lim_{x \rightarrow 0} \frac{\sqrt{1-2x-x^2}-(1+x)}{x}.$$

$$447. \lim_{x \rightarrow 0} \frac{\sqrt[3]{27+x}-\sqrt[3]{27-x}}{x+2\sqrt[3]{x^4}}.$$

$$449. \lim_{x \rightarrow 7} \frac{\sqrt{x+2}-\sqrt[3]{x+20}}{\sqrt[4]{x+9}-2}.$$

$$451. \lim_{x \rightarrow 0} \frac{x^2}{\sqrt[5]{1+5x}-(1+x)}.$$

$$453. \lim_{x \rightarrow 0} \frac{\sqrt[m]{1+ax}\sqrt[n]{1+bx}-1}{x} \quad (m, n \in \mathbb{Z}).$$

454. $P(x) = a_1x + a_2x^2 + \dots + a_nx^n$ va $m \in \mathbb{Z}$ bo'lsin. Quyidagi tenglikni isbotlang:

$$\lim_{x \rightarrow 0} \frac{\sqrt[m]{1+P(x)}-1}{x} = \frac{a_1}{m}.$$

$$455. \lim_{x \rightarrow 1} \frac{\sqrt[n]{x}-1}{\sqrt[m]{x}-1} \quad (m, n \in \mathbb{Z}).$$

$$456. \lim_{x \rightarrow 1} \frac{(1-\sqrt{x})(1-\sqrt[3]{x})\dots(1-\sqrt[n]{x})}{(1-x)^{n-1}}.$$

$$458. \lim_{x \rightarrow +\infty} \left(\sqrt{x} + \sqrt{x+\sqrt{x}} - \sqrt{x} \right).$$

$$460. \lim_{x \rightarrow +0} \left(\sqrt{\frac{1}{x}} + \sqrt{\frac{1}{x} + \sqrt{\frac{1}{x}}} - \sqrt{\frac{1}{x}} - \sqrt{\frac{1}{x} + \sqrt{\frac{1}{x}}} \right).$$

$$462. \lim_{x \rightarrow +\infty} \left(\sqrt[3]{x^3+3x^2} - \sqrt{x^2-2x} \right).$$

$$464. \lim_{x \rightarrow +\infty} x^{\frac{3}{2}} \left(\sqrt{x+2} - 2\sqrt{x+1} + \sqrt{x} \right).$$

$$438. \lim_{x \rightarrow -8} \frac{\sqrt{1-x}-3}{2+\sqrt[3]{x}}.$$

$$440. \lim_{x \rightarrow 3} \frac{\sqrt{x+13}-2\sqrt{x+1}}{x^2-9}.$$

$$442. \lim_{x \rightarrow 16} \frac{\sqrt[4]{x}-2}{\sqrt{x}-4}.$$

$$444. \lim_{x \rightarrow 0} \frac{\sqrt[n]{1+x}-1}{x} \quad (n \in \mathbb{Z}).$$

$$446. \lim_{x \rightarrow 0} \frac{\sqrt[3]{8+3x-x^2}-2}{x+x^2}.$$

$$448. \lim_{x \rightarrow 0} \frac{\sqrt{1+x}-\sqrt{1-x}}{\sqrt[3]{1+x}-\sqrt[3]{1-x}}.$$

$$450. \lim_{x \rightarrow 0} \frac{\sqrt[3]{1+\frac{x}{3}} - \sqrt[4]{1+\frac{x}{4}}}{1 - \sqrt{1-\frac{x}{2}}}.$$

$$452. \lim_{x \rightarrow 0} \frac{\sqrt[m]{1+ax} - \sqrt[n]{1+bx}}{x} \quad (m, n \in \mathbb{Z}).$$

$$455.1. \lim_{x \rightarrow 1} \left(\frac{3}{1-\sqrt{x}} - \frac{2}{1-\sqrt[3]{x}} \right).$$

$$457. \lim_{x \rightarrow +\infty} \left(\sqrt{(x+a)(x+b)} - x \right).$$

$$459. \lim_{x \rightarrow +\infty} x \left(\sqrt{x^2+2x} - 2\sqrt{x^2+x} + x \right).$$

$$461. \lim_{x \rightarrow \infty} \left(\sqrt[3]{x^3+x^2+1} - \sqrt[3]{x^3-x^2+1} \right).$$

$$463. \lim_{x \rightarrow \infty} x^{\frac{1}{3}} \left[(x+1)^{\frac{2}{3}} - (x-1)^{\frac{2}{3}} \right].$$

$$465. \lim_{x \rightarrow +\infty} \left(\sqrt[n]{(x+a_1)\dots(x+a_n)} - x \right).$$

$$466. \lim_{x \rightarrow +\infty} \frac{(x - \sqrt{x^2 - 1})^n + (x + \sqrt{x^2 - 1})^n}{x^n} \quad (n \in \mathbb{N}).$$

$$467. \lim_{x \rightarrow 0} \frac{(\sqrt{1+x^2} + x)^n - (\sqrt{1+x^2} - x)^n}{x} \quad (n \in \mathbb{N}).$$

468. $ax^2 + bx + c = 0$ kvadrat tenglama berilgan, bunda $b, c = \text{const}$, $b \neq 0$, $a \rightarrow 0$. Tenglamaning x_1, x_2 - ildizlari xarakterini o`rganing ($\lim_{a \rightarrow 0} x_1$ va $\lim_{a \rightarrow 0} x_2$ larni toping).

$$469. \lim_{x \rightarrow \infty} \left(\frac{x^2 + 1}{x + 1} - ax - b \right) = 0 \text{ bo`lsa, } a \text{ va } b \text{ larni toping.}$$

470. Agar $\lim_{x \rightarrow -\infty} (\sqrt{x^2 - x + 1} - a_1x - b_1) = 0$ va $\lim_{x \rightarrow +\infty} (\sqrt{x^2 - x + 1} - a_2x - b_2) = 0$ bo`lsa, u holda a_1, a_2, b_1, b_2 larni toping.

Limitlarni toping (471-480, 482-563):

$$471. \lim_{x \rightarrow 0} \frac{\sin 5x}{x}. \quad 472. \lim_{x \rightarrow \infty} \frac{\sin x}{x}. \quad 473. \lim_{x \rightarrow 0} \frac{\sin mx}{\sin nx} \quad (m, n \in \mathbb{Z}).$$

$$474. \lim_{x \rightarrow 0} \frac{1 - \cos x}{x^2}. \quad 474.1. \lim_{x \rightarrow 0} \frac{\text{tg}x}{x}. \quad 474.2. \lim_{x \rightarrow 0} (x \text{ctg} 3x).$$

$$475. \lim_{x \rightarrow 0} \frac{\text{tg}x - \sin x}{\sin^3 x}. \quad 476. \lim_{x \rightarrow 0} \frac{\sin 5x - \sin 3x}{\sin x}. \quad 477. \lim_{x \rightarrow 0} \frac{\cos x - \cos 3x}{x^2}.$$

$$478. \lim_{x \rightarrow 0} \frac{1 + \sin x - \cos x}{1 + \sin px - \cos px} \quad 479. \lim_{x \rightarrow \frac{p}{4}} \text{tg} 2x \text{tg} \left(\frac{p}{4} - x \right). \quad 480. \lim_{x \rightarrow 1} (1-x) \text{tg} \frac{px}{2}$$

481. Tengliklarni isbotlang:

$$a) \lim_{x \rightarrow a} \sin x = \sin a; \quad b) \lim_{x \rightarrow a} \cos x = \cos a; \quad v) \lim_{x \rightarrow a} \text{tg}x = \text{tga} \left(a \neq \frac{2n-1}{2}p; n \in \mathbb{Z} \right).$$

$$482. \lim_{x \rightarrow a} \frac{\sin x - \sin a}{x - a}. \quad 483. \lim_{x \rightarrow a} \frac{\cos x - \cos a}{x - a}. \quad 484. \lim_{x \rightarrow a} \frac{\text{tg}x - \text{tga}}{x - a}.$$

$$485. \lim_{x \rightarrow a} \frac{\text{ctg}x - \text{ctga}}{x - a}. \quad 486. \lim_{x \rightarrow a} \frac{\sec x - \text{seca}}{x - a}. \quad 487. \lim_{x \rightarrow a} \frac{\cos ecx - \cos eca}{x - a}.$$

$$488. \lim_{x \rightarrow 0} \frac{\sin(a+2x) - 2\sin(a+x) + \sin a}{x^2}. \quad 489. \lim_{x \rightarrow 0} \frac{\cos(a+2x) - 2\cos(a+x) + \cos a}{x^2}.$$

$$490. \lim_{x \rightarrow 0} \frac{\text{tg}(a+2x) - 2\text{tg}(a+x) + \text{tga}}{x^2}. \quad 491. \lim_{x \rightarrow 0} \frac{\text{ctg}(a+2x) - 2\text{ctg}(a+x) + \text{ctga}}{x^2}.$$

$$492. \lim_{x \rightarrow 0} \frac{\sin(a+x)\sin(a+2x) - \sin^2 a}{x}. \quad 493. \lim_{x \rightarrow \frac{p}{6}} \frac{2\sin^2 x + \sin x - 1}{2\sin^2 x - 3\sin x + 1}.$$

$$494. \lim_{x \rightarrow 0} \frac{1 - \cos x \cdot \cos 2x \cdot \cos 3x}{1 - \cos x}. \quad 495. \lim_{x \rightarrow \frac{p}{3}} \frac{\sin\left(x - \frac{p}{3}\right)}{1 - 2\cos x}.$$

$$496. \lim_{x \rightarrow \frac{p}{3}} \frac{\text{tg}^3 x - 3\text{tg}x}{\cos\left(x + \frac{p}{6}\right)}. \quad 497. \lim_{x \rightarrow 0} \frac{\text{tg}(a+x)\text{tg}(a-x) - \text{tg}^2 a}{x^2}.$$

$$498. \lim_{x \rightarrow \frac{p}{4}} \frac{1 - \text{ctg}^3 x}{2 - \text{ctg}x - \text{ctg}^3 x}. \quad 499. \lim_{x \rightarrow 0} \frac{\sqrt{1+\text{tg}x} - \sqrt{1+\sin x}}{x^3}.$$

$$500. \lim_{x \rightarrow 0} \frac{x^2}{\sqrt{1+x\sin x} - \sqrt{\cos x}}. \quad 501. \lim_{x \rightarrow 0} \frac{\sqrt{\cos x} - \sqrt[3]{\cos x}}{\sin^2 x}.$$

$$502. \lim_{x \rightarrow 0} \frac{\sqrt{1 - \cos x^2}}{1 - \cos x}.$$

$$503. \lim_{x \rightarrow 0} \frac{1 - \sqrt{\cos x}}{1 - \cos \sqrt{x}}.$$

$$504. \lim_{x \rightarrow 0} \frac{1 - \cos x \sqrt{\cos 2x} \sqrt[3]{\cos 3x}}{x^2}.$$

$$505. \lim_{x \rightarrow +\infty} (\sin \sqrt{x+1} - \sin \sqrt{x}).$$

$$506. \text{ a) } \lim_{x \rightarrow 0} \left(\frac{1+x}{2+x} \right)^{\frac{1-\sqrt{x}}{1-x}}; \quad \text{ b) } \lim_{x \rightarrow 1} \left(\frac{1+x}{2+x} \right)^{\frac{1-\sqrt{x}}{1-x}}; \quad \text{ v) } \lim_{x \rightarrow +\infty} \left(\frac{1+x}{2+x} \right)^{\frac{1-\sqrt{x}}{1-x}}.$$

$$507. \lim_{x \rightarrow \infty} \left(\frac{x+2}{2x-1} \right)^{x^2}.$$

$$508. \lim_{x \rightarrow \infty} \left(\frac{3x^2 - x + 1}{2x^2 + x + 1} \right)^{\frac{x^2}{1-x}}.$$

$$509. \lim_{n \rightarrow \infty} \left(\sin^n \frac{2pn}{3n+1} \right).$$

$$510. \lim_{x \rightarrow \frac{p}{4} + 0} \left(\operatorname{tg} \left(\frac{p}{8} + x \right) \right)^{\operatorname{tg} 2x}.$$

$$511. \lim_{x \rightarrow \infty} \left(\frac{x^2 - 1}{x^2 + 1} \right)^{\frac{x-1}{x+1}}.$$

$$512. \lim_{x \rightarrow \infty} \left(\frac{x^2 + 1}{x^2 - 2} \right)^{x^2}.$$

$$513. \lim_{x \rightarrow \infty} \left(\frac{x^2 + 2x - 1}{2x^2 - 3x - 2} \right)^{\frac{1}{x}}.$$

$$514. \lim_{x \rightarrow 0} \sqrt[3]{1 - 2x}.$$

$$515. \lim_{x \rightarrow \infty} \left(\frac{x+a}{x-a} \right)^x.$$

$$516. \lim_{x \rightarrow +\infty} \left(\frac{a_1 x + b_1}{a_2 x + b_2} \right)^x \quad (a_1 > 0, a_2 > 0).$$

$$517. \lim_{x \rightarrow 0} (1 + x^2)^{\operatorname{ctg}^2 x}.$$

$$518. \lim_{x \rightarrow 1} (1 + \sin px)^{\operatorname{ctg} px}.$$

$$519. \lim_{x \rightarrow 0} \left(\frac{1 + \operatorname{tg} x}{1 + \sin x} \right)^{\frac{1}{\sin x}}.$$

$$519.1. \lim_{x \rightarrow 0} \left(\frac{1 + \operatorname{tg} x}{1 + \sin x} \right)^{\frac{1}{\sin^3 x}}.$$

$$520. \lim_{x \rightarrow a} \left(\frac{\sin x}{\sin a} \right)^{\frac{1}{x-a}}.$$

$$521. \lim_{x \rightarrow 0} \left(\frac{\cos x}{\cos 2x} \right)^{\frac{1}{x^2}}.$$

$$522. \lim_{x \rightarrow p/4} (\operatorname{tg} x)^{\operatorname{tg} 2x}.$$

$$523. \lim_{x \rightarrow p/2} (\sin x)^{\operatorname{tg} x}.$$

$$524. \lim_{x \rightarrow 0} \left[\operatorname{tg} \left(\frac{p}{4} - x \right) \right]^{\operatorname{ctg} x}.$$

$$525. \lim_{x \rightarrow \infty} \left(\sin \frac{1}{x} + \cos \frac{1}{x} \right)^x.$$

$$526. \lim_{x \rightarrow 0} \sqrt[3]{\cos \sqrt{x}}.$$

$$527. \lim_{n \rightarrow \infty} \left(\frac{n+1}{n-1} \right)^n.$$

$$528. \lim_{n \rightarrow \infty} \cos^n \frac{x}{\sqrt{n}}.$$

$$529. \lim_{x \rightarrow 0} \frac{\ln(1+x)}{x}.$$

$$530. \lim_{x \rightarrow +\infty} x [\ln(x+1) - \ln x].$$

$$531. \lim_{x \rightarrow a} \frac{\ln x - \ln a}{x - a} \quad (a > 0).$$

$$532. \lim_{x \rightarrow +\infty} [\sin \ln(x+1) - \sin \ln x].$$

$$533. \lim_{x \rightarrow +\infty} \frac{\ln(x^2 - x + 1)}{\ln(x^{10} + x + 1)}.$$

$$534. \lim_{x \rightarrow \infty} \left(\operatorname{tg} \frac{100 + x^2}{1 + 100x^2} \right).$$

$$535. \lim_{x \rightarrow +\infty} \frac{\ln(2 + e^{3x})}{\ln(3 + e^{2x})}.$$

$$536. \lim_{x \rightarrow +\infty} \frac{\ln(1 + \sqrt{x} + \sqrt[3]{x})}{\ln(1 + \sqrt[3]{x} + \sqrt[4]{x})}.$$

$$537. \lim_{h \rightarrow 0} \frac{\log(x+h) + \log(x-h) - 2 \log x}{h^2} \quad (x > 0).$$

$$538. \lim_{x \rightarrow 0} \frac{\ln \operatorname{tg} \left(\frac{p}{4} + ax \right)}{\sin bx}.$$

$$539. \lim_{x \rightarrow 0} \frac{\ln \cos ax}{\ln \cos bx}.$$

$$540. \lim_{x \rightarrow 0} \left(\ln \frac{nx + \sqrt{1 - n^2 x^2}}{x + \sqrt{1 - x^2}} \right).$$

$$540.1. \lim_{x \rightarrow 0} \frac{\ln(nx + \sqrt{1 - n^2 x^2})}{\ln(x + \sqrt{1 - x^2})}.$$

$$541. \lim_{x \rightarrow 0} \frac{a^x - 1}{x} \quad (a > 0).$$

$$543. \lim_{x \rightarrow a} \frac{x^x - a^a}{x - a} \quad (a > 0).$$

$$545. \lim_{x \rightarrow 0} \left(\frac{1 + x \cdot 2^x}{1 + x \cdot 3^x} \right)^{\frac{1}{x^2}}.$$

$$545.2. \lim_{x \rightarrow 1} \frac{\sin(px^a)}{\sin(px^b)}.$$

$$546. \lim_{n \rightarrow \infty} \operatorname{tg}^n \left(\frac{p}{4} + \frac{1}{n} \right).$$

$$548. \lim_{x \rightarrow a} \frac{x^a - a^a}{x^b - a^b} \quad (a > 0).$$

$$550. \lim_{h \rightarrow 0} \frac{a^{x+h} + a^{x-h} - 2a^x}{h^2} \quad (a > 0).$$

$$552. \lim_{n \rightarrow \infty} n \left(\sqrt[n]{x} - 1 \right) \quad (x > 0).$$

$$554. \lim_{n \rightarrow \infty} \left(\frac{a - 1 + \sqrt[n]{b}}{a} \right)^n \quad (a > 0, b > 0).$$

$$556. \lim_{x \rightarrow 0} \left(\frac{a^x + b^x + c^x}{3} \right)^{\frac{1}{x}} \quad (a > 0, b > 0, c > 0).$$

$$557. \lim_{x \rightarrow 0} \left(\frac{a^{x+1} + b^{x+1} + c^{x+1}}{a + b + c} \right)^{\frac{1}{x}} \quad (a > 0, b > 0, c > 0).$$

$$558. \lim_{x \rightarrow 0} \left(\frac{a^{x^2} + b^{x^2}}{a^x + b^x} \right)^{\frac{1}{x}} \quad (a > 0, b > 0).$$

$$559. \lim_{x \rightarrow 0} \frac{a^{x^2} - b^{x^2}}{(a^x - b^x)^2} \quad (a > 0, b > 0).$$

$$561. \text{ a) } \lim_{x \rightarrow -\infty} \frac{\ln(1 + 3^x)}{\ln(1 + 2^x)};$$

$$562. \lim_{x \rightarrow +\infty} \ln(1 + 2^x) \ln \left(1 + \frac{3}{x} \right).$$

$$564. \text{ Isbotlang: } \lim_{x \rightarrow +\infty} \frac{x^n}{a^x} = 0 \quad (a > 1, n > 0).$$

$$565. \text{ Isbotlang: } \lim_{x \rightarrow +\infty} \frac{\log_a x}{x^e} = 0 \quad (a > 1, e > 0).$$

Limitlarni toping (566-594):

$$566. \text{ a) } \lim_{x \rightarrow 0} \frac{\ln(x^2 + e^x)}{\ln(x^4 + e^{2x})}; \text{ b) } \lim_{x \rightarrow +\infty} \frac{\ln(x^2 + e^x)}{\ln(x^4 + e^{2x})}.$$

$$542. \lim_{x \rightarrow a} \frac{a^x - x^a}{x - a} \quad (a > 0).$$

$$544. \lim_{x \rightarrow 0} (x + e^x)^{\frac{1}{x}}.$$

$$545.1. \lim_{x \rightarrow 0} \left(\frac{1 + \sin x \cos ax}{1 + \sin x \cos bx} \right)^{\operatorname{ctg}^3 x}.$$

$$545.3. \lim_{x \rightarrow 1} \frac{\sin^2(p \cdot 2^x)}{\ln[\cos(p \cdot 2^x)]}.$$

$$547. \lim_{x \rightarrow 0} \frac{e^{ax} - e^{bx}}{\sin ax - \sin bx}.$$

$$549. \lim_{x \rightarrow b} \frac{a^x - a^b}{x - b} \quad (a > 0).$$

$$551. \lim_{x \rightarrow \infty} \frac{(x+a)^{x+a} (x+b)^{x+b}}{(x+a+b)^{2x+a+b}}.$$

$$553. \lim_{n \rightarrow \infty} n^2 \left(\sqrt[n]{x} - \sqrt[n+1]{x} \right) \quad (x > 0).$$

$$555. \lim_{n \rightarrow \infty} \left(\frac{\sqrt[n]{a} + \sqrt[n]{b}}{2} \right)^n \quad (a > 0, b > 0).$$

$$560. \lim_{x \rightarrow a} \frac{a^{a^x} - a^{x^a}}{a^x - x^a} \quad (a > 0).$$

$$\text{ b) } \lim_{x \rightarrow +\infty} \frac{\ln(1 + 3^x)}{\ln(1 + 2^x)}.$$

$$563. \lim_{x \rightarrow 1} (1-x) \log_x 2.$$

$$567. \lim_{x \rightarrow 0} \frac{\ln(1 + xe^x)}{\ln(x + \sqrt{1 + x^2})}.$$

$$568. \lim_{x \rightarrow +\infty} [(x+2) \ln(x+2) - 2(x+1) \ln(x+1) + x \ln x].$$

$$569. \lim_{x \rightarrow +0} \left[\ln(x \ln a) \cdot \ln \left(\frac{\ln ax}{\ln \frac{x}{a}} \right) \right] \quad (a > 1).$$

$$570. \lim_{x \rightarrow +\infty} \left(\ln \frac{x + \sqrt{x^2 + 1}}{x + \sqrt{x^2 - 1}} \cdot \ln^{-2} \frac{x+1}{x-1} \right).$$

$$571. \lim_{x \rightarrow 0} \frac{\sqrt{1 + x \sin x} - 1}{e^{x^2} - 1}.$$

$$572. \lim_{x \rightarrow 0} \frac{\cos(xe^x) - \cos(xe^{-x})}{x^3}.$$

$$573. \lim_{x \rightarrow 0} \left(2e^{\frac{x}{x+1}} - 1 \right)^{\frac{x^2+1}{x}}.$$

$$574. \lim_{x \rightarrow 1} (2-x)^{\sec \frac{px}{2}}.$$

$$575. \lim_{x \rightarrow p/2} \frac{1 - \sin^{a+b} x}{\sqrt{(1 - \sin^a x)(1 - \sin^b x)}} \quad (a > 0, b > 0).$$

$$576. \text{ a) } \lim_{x \rightarrow 0} \frac{shx}{x}; \quad \text{ b) } \lim_{x \rightarrow 0} \frac{chx - 1}{x^2}; \quad \text{ v) } \lim_{x \rightarrow 0} \frac{thx}{x} \quad (340 - \text{ misolga qarang}).$$

$$576.1. \lim_{x \rightarrow 0} \frac{sh^2 x}{\ln(ch3x)} \quad (340 - \text{ misolga qarang}).$$

$$577. \lim_{x \rightarrow +\infty} \frac{sh\sqrt{x^2 + x} - sh\sqrt{x^2 - x}}{chx}.$$

$$577.1. \text{ a) } \lim_{x \rightarrow a} \frac{shx - sha}{x - a}; \quad \text{ b) } \lim_{x \rightarrow a} \frac{chx - cha}{x - a}.$$

$$577.2. \lim_{x \rightarrow 0} \frac{\ln chx}{\ln \cos x}.$$

$$578. \lim_{x \rightarrow +\infty} (x - \ln chx).$$

$$579. \lim_{x \rightarrow 0} \frac{e^{\sin 2x} - e^{\sin x}}{thx}.$$

$$580. \lim_{n \rightarrow \infty} \left(\frac{ch \frac{p}{n}}{\cos \frac{p}{n}} \right)^{n^2}.$$

$$581. \lim_{x \rightarrow \infty} \arcsin \frac{1-x}{1+x}.$$

$$582. \lim_{x \rightarrow +\infty} \arccos(\sqrt{x^2 + x} - x).$$

$$583. \lim_{x \rightarrow 2} \arctg \frac{x-4}{(x-2)^2}.$$

$$584. \lim_{x \rightarrow \infty} \arctg \frac{x}{\sqrt{1+x^2}}.$$

$$585. \lim_{h \rightarrow 0} \frac{\arctg(x+h) - \arctgx}{h}.$$

$$586. \lim_{x \rightarrow 0} \frac{\ln \frac{1+x}{1-x}}{\arctg(1+x) - \arctg(1-x)}.$$

$$587. \lim_{n \rightarrow \infty} \left[n \arctg \frac{1}{n(x^2+1)+x} \cdot \text{tg}^n \left(\frac{p}{4} + \frac{x}{2n} \right) \right].$$

$$588. \lim_{x \rightarrow \infty} x \left(\frac{p}{4} - \arctg \frac{x}{x+1} \right).$$

$$589. \lim_{x \rightarrow +\infty} x \left(\frac{p}{2} - \arcsin \frac{x}{\sqrt{x^2+1}} \right).$$

$$590. \lim_{n \rightarrow \infty} \left[1 + \frac{(-1)^n}{n} \right]^{\cos ec(p\sqrt{1+n^2})}.$$

$$591. \lim_{x \rightarrow 0} \frac{1}{x^{100}} e^{x^2}.$$

$$592. \lim_{x \rightarrow +0} x \ln x.$$

$$593. \text{ a) } \lim_{x \rightarrow -\infty} (\sqrt{x^2 + x} - x);$$

$$\text{ b) } \lim_{x \rightarrow +\infty} (\sqrt{x^2 + x} - x).$$

$$594. \text{ a) } \lim_{x \rightarrow -\infty} (\sqrt{1+x+x^2} - \sqrt{1-x+x^2});$$

$$\text{ b) } \lim_{x \rightarrow +\infty} (\sqrt{1+x+x^2} - \sqrt{1-x+x^2}).$$

$$594.1. \text{ Agar } f(x) = \ln \frac{x + \sqrt{x^2 + a^2}}{x + \sqrt{x^2 + b^2}} \text{ bo`lsa, } h = \lim_{x \rightarrow +\infty} f(x) - \lim_{x \rightarrow -\infty} f(x) \text{ ni toping.}$$

$$595. a) \lim_{x \rightarrow 1-0} \operatorname{arctg} \frac{1}{1-x}; \quad \delta) \lim_{x \rightarrow 1+0} \operatorname{arctg} \frac{1}{1-x}.$$

$$596. a) \lim_{x \rightarrow -\infty} \frac{1}{1+e^{1/x}}; \quad \delta) \lim_{x \rightarrow +0} \frac{1}{1+e^{1/x}}$$

$$597. a) \lim_{x \rightarrow -\infty} \frac{\ln(1+e^x)}{x}; \quad \delta) \lim_{x \rightarrow +\infty} \frac{\ln(1+e^x)}{x}.$$

$$598. \text{Isbotlang: } a) \lim_{x \rightarrow -\infty} \frac{2x}{1+x} = 2+0; \quad \delta) \lim_{x \rightarrow +\infty} \frac{2x}{1+x} = 2-0.$$

$$599. \text{Isbotlang: } a) x \rightarrow -0 \text{ da } 2^x \rightarrow 1-0; \quad \delta) x \rightarrow +0 \text{ da } 2^x \rightarrow 1+0.$$

600. Agar $f(x) = x + [x^2]$ bo`lsa, $f(1)$, $f(1-0)$, $f(1+0)$ larni toping.

601. Agar $f(x) = \operatorname{sgn}(\sin px)$ bo`lsa $f(n)$, $f(n-0)$, $f(n+0)$ ($n \in Z$) larni toping.

Hisoblang (602-606):

$$602. \lim_{x \rightarrow 0} x \sqrt{\cos \frac{1}{x}}. \quad 603. \lim_{x \rightarrow 0} x \left[\frac{1}{x} \right]. \quad 604. \lim_{n \rightarrow \infty} \sin(p\sqrt{n^2+1}).$$

$$605. \lim_{n \rightarrow \infty} \sin^2(p\sqrt{n^2+n}). \quad 606. \lim_{n \rightarrow \infty} \sin \sin \dots \sin x.$$

n марта

607. Agar $\lim_{x \rightarrow a} j(x) = A$ va $\lim_{x \rightarrow A} y(x) = B$ bo`lsa, bundan $\lim_{x \rightarrow a} y(j(x)) = B$ ekanligi kelib chiqadimi?

Ushbu misolni ko`ring: $x = \frac{p}{q}$ bo`lganda $j(x) = \frac{1}{q}$, bunda p, q - o`zaro tub bo`lgan butun sonlar va x - irratsional bo`lganda $j(x) = 0$; $x \neq 0$ bo`lganda $y(x) = 1$ va $x = 0$ bo`lganda $y(x) = 0$; shu bilan birga $x \rightarrow 0$.

608. Koshi teoremlarini isbotlang: agar $f(x)$ funksiya $(a, +\infty)$ oraliqda aniqlangan va har bir (a, b) chekli oraliqda chegaralangan bo`lsa, u holda

$$a) \lim_{x \rightarrow +\infty} \frac{f(x)}{x} = \lim_{x \rightarrow +\infty} [f(x+1) - f(x)];$$

$$\delta) \lim_{x \rightarrow +\infty} [f(x)]^{1/x} = \lim_{x \rightarrow +\infty} \frac{f(x+1)}{f(x)} \quad (f(x) \geq C > 0),$$

o`rinli, bunda tengliklarning o`ng tomonlaridagi limitlar mavjud deb faraz qilamiz.

609. Agar a) $f(x)$ funksiya $x > a$ sohada aniqlangan; b) har bir $a < x < b$ chekli sohada chegaralangan; e) $\lim_{x \rightarrow +\infty} [f(x+1) - f(x)] = \infty$ tenglik bajarilsa, u holda

$$\lim_{x \rightarrow +\infty} \frac{f(x)}{x} = \infty$$

bo`lishini isbotlang.

610. Agar 1) $f(x)$ funksiya $x > a$ sohada aniqlangan; 2) har bir $a < x < b$ chekli sohada chegaralangan; 3) biror natural n son uchun ushbu

$$\lim_{x \rightarrow +\infty} \frac{f(x+1) - f(x)}{x^n} = l$$

chekli yoki cheksiz limit mavjud bo`lsa, u holda

$$\lim_{x \rightarrow +\infty} \frac{f(x)}{x^{n+1}} = \frac{l}{n+1}$$

ekanligini isbotlang.

611. Isbotlang: a) $\lim_{n \rightarrow \infty} \left(1 + \frac{x}{n}\right)^n = e^x$; b) $\lim_{n \rightarrow \infty} \left(1 + x + \frac{x^2}{2!} + \dots + \frac{x^n}{n!}\right) = e^x$.

612. Isbotlang: $\lim_{n \rightarrow \infty} n \sin(2p\pi/n) = 2p$.

Yo'llanma. 72 – misoldagi (*) formulani qo'llang.

Quyidagi funksiyalarning grafigini yasang (613-625.2):

613. a) $y = 1 - x^{100}$;

b) $y = \lim_{n \rightarrow \infty} (1 - x^{2n}) \quad (-1 \leq x \leq 1)$.

614. a) $y = \frac{x^{100}}{1 + x^{100}} \quad (x \geq 0)$;

b) $y = \lim_{n \rightarrow \infty} \frac{x^n}{1 + x^n} \quad (x \geq 0)$.

615. $y = \lim_{n \rightarrow \infty} \frac{x^n - x^{-n}}{x^n + x^{-n}} \quad (x \neq 0)$.

616. $y = \lim_{n \rightarrow \infty} \sqrt{x^2 + \frac{1}{n^2}}$.

617. $y = \lim_{n \rightarrow \infty} \sqrt[n]{1 + x^n} \quad (x \geq 0)$.

618. $y = \lim_{n \rightarrow \infty} \sqrt[n]{1 + x^n + \left(\frac{x^2}{2}\right)^n} \quad (x \geq 0)$.

619. $y = \lim_{n \rightarrow \infty} \frac{x^{n+2}}{\sqrt{2^{2n} + x^{2n}}} \quad (x \geq 0)$.

620. a) $y = \sin^{1000} x$;

b) $y = \lim_{n \rightarrow \infty} \sin^{2n} x$.

621. $y = \lim_{n \rightarrow \infty} \frac{\ln(2^n + x^n)}{n} \quad (x \geq 0)$.

622. $y = \lim_{n \rightarrow \infty} (x - 1) \operatorname{arctg} x^n$.

623. $y = \lim_{n \rightarrow \infty} \sqrt[n]{1 + e^{n(x+1)}}$.

624. $y = \lim_{t \rightarrow +\infty} \frac{x + e^{tx}}{1 + e^{tx}}$.

625. $y = \lim_{t \rightarrow x} \frac{1}{t - x} \ln \frac{t}{x} \quad (x > 0)$.

625.1. $y = \lim_{n \rightarrow \infty} \frac{xtg^{2n} \frac{px}{4} + \sqrt{x}}{tg^{2n} \frac{px}{4} + 1} \quad (x \geq 0)$.

625.2. $y = \lim_{n \rightarrow \infty} x \operatorname{sgn} |\sin^2(n!px)|$.

625.3. egri chiziqni quring: $\lim_{n \rightarrow \infty} \sqrt[n]{|x|^n + |y|^n} = 1$

626. Agar $y = f(x)$ egri chiziq uchun

$$\lim_{x \rightarrow \infty} [f(x) - (kx + b)] = 0$$

shart bajarilsa, u holda $y = kx + b$ to'g'ri chiziq $y = f(x)$ egri chiziq uchun asimptota (og'ma) deyiladi. YUqoridagi tenglamani qo'llab asimptota mavjud bo'lishining zaruriy va etarli shartlarini keltirib chiqaring.

627. Quyidagi chiziqlarning asimptotalarini toping va grafigini yasang:

a) $y = \frac{x^3}{x^2 + x - 2}$; b) $y = \sqrt{x^2 + x}$; v) $y = \sqrt[3]{x^2 - x^3}$;

g) $y = \frac{xe^x}{e^x - 1}$; d) $y = \ln(1 + e^x)$; e) $y = x + \arccos \frac{1}{x}$.

Quyidagi limitlarni toping (628-630):

628. $\lim_{n \rightarrow \infty} \left[\frac{x^{n+1}}{(n+1)!} + \frac{x^{n+2}}{(n+2)!} + \dots + \frac{x^{2n}}{(2n)!} \right]$.

629. $\lim_{n \rightarrow \infty} \left[(1+x)(1+x^2)(1+x^4) \dots (1+x^{2^n}) \right], |x| < 1$.

$$630. \lim_{n \rightarrow \infty} \left(\cos \frac{x}{2} \cos \frac{x}{4} \dots \cos \frac{x}{2^n} \right).$$

$$631. \lim_{x \rightarrow 0} \frac{j(x)}{y(x)} = 1, \quad y(x) > 0 \quad \text{va} \quad n \rightarrow \infty \quad \text{da} \quad a_{mn} \rightarrow 0 \quad (m = 1, 2, \dots) \quad \text{bo'lsin, ya'ni}$$

$m = 1, 2, \dots$ va $n > N(\epsilon)$ bo'lganda $|a_{mn}| < \epsilon$ tengsizlik bajarilsin. U holda

$$\lim_{n \rightarrow \infty} [j(a_{1n}) + j(a_{2n}) + \dots + j(a_{mn})] = \lim_{n \rightarrow \infty} [y(a_{1n}) + y(a_{2n}) + \dots + y(a_{mn})]$$

tenglikni isbotlang, bunda tenglikning o'ng tomonidagi limit mavjud deb faraz qiling.

Avvalgi teoremadan foydalanib, quyidagilarni toping (632-636):

$$632. \lim_{n \rightarrow \infty} \sum_{k=1}^n \left(\sqrt[3]{1 + \frac{k}{n^2}} - 1 \right).$$

$$633. \lim_{n \rightarrow \infty} \sum_{k=1}^n \sin \frac{ka}{n^2}.$$

$$634. \lim_{n \rightarrow \infty} \sum_{k=1}^n \left(a^{k/n^2} - 1 \right) \quad (a > 0).$$

$$635. \lim_{n \rightarrow \infty} \prod_{k=1}^n \left(1 + \frac{k}{n^2} \right).$$

$$636. \lim_{n \rightarrow \infty} \prod_{k=1}^n \cos \frac{ka}{n\sqrt{n}}.$$

637. x_n ketma-ketlik quyidagi tengliklar bilan berilgan:

$$x_1 = \sqrt{a}, \quad x_2 = \sqrt{a + \sqrt{a}}, \quad x_3 = \sqrt{a + \sqrt{a + \sqrt{a}}}, \quad \dots, \quad (a > 0).$$

$\lim_{n \rightarrow \infty} x_n$ ni toping.

637.1. x_n ketma-ketlik quyidagicha berilgan:

$$x_1 = 0, \quad x_2 = 1, \quad x_n = \frac{1}{2}(x_{n-1} + x_{n-2}) \quad (n = 2, 3, \dots).$$

$\lim_{n \rightarrow \infty} x_n$ ni toping.

637.2. y_n ketma-ketlik x_n ketma-ketlik yordamida quyidagi munosabatlar orqali aniqlanadi:

$$y_0 = x_0, \quad y_n = x_n - a x_{n-1} \quad (n = 1, 2, \dots)$$

bunda $|a| < 1$. Agar $\lim_{n \rightarrow \infty} y_n = b$ bo'lsa, $\lim_{n \rightarrow \infty} x_n$ ni toping.

637.3. x_n ketma-ketlik quyidagicha aniqlanadi:

$$x_0 = 1, \quad x_n = \frac{1}{1 + x_{n-1}} \quad (n = 1, 2, \dots).$$

$\lim_{n \rightarrow \infty} x_n$ ni toping.

Y o`ll a n m a. x_n va $x = \frac{1}{1+x}$ tenglamaning ildizlari orasidagi ayirmani ko'ring.

638. $y_n = y_n(x)$ ($0 \leq x \leq 1$) funksiyalar ketma-ketligi quyidagicha aniqlanadi:

$$y_1 = \frac{x}{2}, \quad y_n = \frac{x}{2} - \frac{y_{n-1}^2}{2} \quad (n = 2, 3, \dots).$$

$\lim_{n \rightarrow \infty} y_n$ ni toping.

639. $y_n = y_n(x)$ ($0 \leq x \leq 1$) funksiyalar ketma-ketligi quyidagicha aniqlanadi:

$$y_1 = \frac{x}{2}, \quad y_n = \frac{x}{2} + \frac{y_{n-1}^2}{2} \quad (n = 2, 3, \dots).$$

$\lim_{n \rightarrow \infty} y_n$ ni toping.

639.1. $x > 0$ va $y_n = y_{n-1}(2 - xy_{n-1})$ ($n = 1, 2, \dots$) bo'lsin. Agar $y_i > 0$ ($i = 0, 1$) bo'lsa, u holda y_n ketma-ketlik yaqinlashuvchi va uning limiti

$$\lim_{n \rightarrow \infty} y_n = \frac{1}{x}$$

ga tengligini isbotlang.

Y o`ll a n m a. $\frac{1}{x} - y_n$ ayirmani o'rganing.

639.2. $y = \sqrt{x}$, $x > 0$ ni topish uchun quyidagicha jarayon qo'llaniladi: $y_0 > 0$ - ixtiyoriy va

$$y_n = \frac{1}{2} \left(y_{n-1} + \frac{x}{y_{n-1}} \right) \quad (n = 1, 2, \dots).$$

U holda $\lim_{n \rightarrow \infty} y_n = \sqrt{x}$ bo'lishini isbotlang.

Y o`ll a n m a. Quyidagi formulani qo'llang:

$$\frac{y_n - \sqrt{x}}{y_n + \sqrt{x}} = \left(\frac{y_{n-1} - \sqrt{x}}{y_{n-1} + \sqrt{x}} \right)^2 \quad (n \geq 1).$$

640. Ushbu

$$x - e \sin x = m \quad (0 < e < 1) \quad (1)$$

Kepler tenglamasining taqribiy echimi uchun quyidagi (ketma-ket yaqinlashish usuli) usul qo'llaniladi:

$$x_0 = m, \quad x_1 = m + e \sin x_0, \quad \dots, \quad x_n = m + e \sin x_{n-1}, \quad \dots$$

$x = \lim_{n \rightarrow \infty} x_n$ limit mavjudligini va x soni (1) tenglamaning yagona echimi ekanligini isbotlang.

641. Agar $w_h[f]$ - $f(x)$ funksiyaning $|x - x| \leq h$ ($h > 0$) kesmadagi tebranishi bo'lsa, u holda

$$w_0[f] = \lim_{h \rightarrow 0} w_h[f]$$

soni $f(x)$ funksiyaning x nuqtadagi tebranishi deyiladi.

Agar $f(0) = 0$ bo'lsa, u holda $x \neq 0$ bo'lganda quyidagi funksiyalarning $x = 0$ nuqtadagi tebranishini aniqlang:

$$\text{a) } f(x) = \sin \frac{1}{x}; \quad \text{b) } f(x) = \frac{1}{x^2} \cos^2 \frac{1}{x}; \quad \text{v) } f(x) = x \left(2 + \sin \frac{1}{x} \right);$$

$$\text{g) } f(x) = \frac{1}{p} \operatorname{arctg} \frac{1}{x}; \quad \text{d) } f(x) = \frac{|\sin x|}{x}; \quad \text{e) } f(x) = \frac{1}{1 + e^{1/x}};$$

$$\text{j) } f(x) = (1 + |x|)^{1/x}.$$

642. $f(x) = \sin \frac{1}{x}$ bo'lsin. U holda $-1 \leq a \leq 1$ shartni qanoatlantiruvchi a son qanday bo'lishidan qat'iy nazar $\lim_{n \rightarrow \infty} f(x_n) = a$ tenglik bajariladigan $x_n \rightarrow 0$ ($n = 1, 2, \dots$) ketma-ketlik tanlash mumkin ekanligini isbotlang.

643. Ushbu

$$\text{a) } f(x) = \sin^2 \frac{1}{x} + \frac{2}{p} \operatorname{arctg} \frac{1}{x}; \quad \text{b) } f(x) = (2 - x^2) \cos \frac{1}{x}; \quad \text{v) } f(x) = \left(1 + \cos^2 \frac{1}{x} \right)^{\sec^2(1/x)}$$

funksiyalar uchun $l = \lim_{x \rightarrow 0} f(x)$ va $L = \overline{\lim}_{x \rightarrow 0} f(x)$ larni aniqlang.

644. Ushbu

a) $f(x) = \sin x$; b) $f(x) = x^2 \cos^2 x$;

v) $f(x) = 2^{\sin x^2}$; $f(x) = \frac{x}{1+x^2 \sin^2 x} \quad (x \geq 0)$

funksiyalar uchun $l = \lim_{x \rightarrow \infty} f(x)$ va $L = \overline{\lim}_{x \rightarrow \infty} f(x)$ larni aniqlang.

6. O-simvolika

645. $AOB = x$ ga teng markaziy burchakni 1-tartibli cheksiz kichik miqdor deb hisoblab, quyidagi kattaliklarning kichiklik tartibini aniqlang (4-rasm):

- a) AB vatar; b) CD kesma;
 v) AOB sektor yuzi;
 g) ABC uchburchak yuzi; d) ABB_1A_1 trapetsiya yuzi;
 e) ABC segment yuzi.

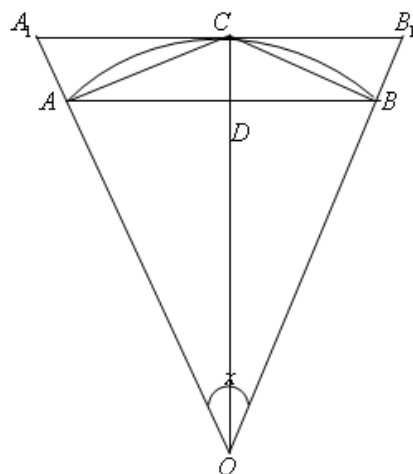

4-расм

646. $o(f(x))$ funksiya $x \rightarrow a$ da $f(x)$ funksiyaga nisbatan kichik o`shish tartibiga ega ixtiyoriy funksiya, $O(f(x))$ funksiya esa $x \rightarrow a$ da $f(x)$ funksiya bilan bir xil o`shish tartibiga ega ixtiyoriy funksiya bo`lsin, bunda $f(x) > 0$.

Quyidagi tengliklarni isbotlang:

- a) $o(o(f(x))) = o(f(x))$; b) $O(o(f(x))) = o(f(x))$;
 v) $o(O(f(x))) = o(f(x))$; g) $O(O(f(x))) = O(f(x))$;
 d) $O(f(x)) + o(f(x)) = O(f(x))$.

647. $x \rightarrow 0$ va $n > 0$ bo`lsin. Isbotlang:

- a) $CO(x^n) = O(x^n)$ ($C \neq 0$ - o`zgarmas son); b) $O(x^n) + O(x^m) = O(x^n)$ ($n < m$);
 v) $O(x^n)O(x^m) = O(x^{n+m})$.

648. $x \rightarrow +\infty$ va $n > 0$ bo`lsin. Isbotlang:

- a) $CO(x^n) = O(x^n)$; b) $O(x^n) + O(x^m) = O(x^n)$ ($n > m$);
 v) $O(x^n)O(x^m) = O(x^{n+m})$.

649. \sim belgisi quyidagi xossalarga ega ekanligini ko`rsating:

- 1) refleksivlik: $j(x) \sim j(x)$; 2) simmetrik: agar $j(x) \sim y(x)$ bo`lsa, u holda $y(x) \sim j(x)$; 3) tranzitivlik: agar $j(x) \sim y(x)$ va $y(x) \sim c(x)$ bo`lsa, u holda $j(x) \sim c(x)$.

650. $x \rightarrow 0$ da quyidagi tengliklar o`rinli ekanligini isbotlang:

- a) $2x - x^2 = O(x)$; b) $x \sin \sqrt{x} = O\left(x^{\frac{3}{2}}\right)$; v) $x \sin \frac{1}{x} = O(|x|)$;
 g) $\ln x = o\left(\frac{1}{x^e}\right)$ ($e > 0$); d) $\sqrt{x + \sqrt{x + \sqrt{x}}} \sim \sqrt[3]{x}$; e) $\arctg \frac{1}{x} = O(1)$;
 j) $(1+x)^n = 1 + nx + o(x)$.

651. $x \rightarrow +\infty$ da quyidagi tengliklar o`rinli ekanligini isbotlang:

a) $2x^3 - 3x^2 + 1 = O(x^3)$; b) $\frac{x+1}{x^2+1} = O\left(\frac{1}{x}\right)$; v) $x + x^2 \sin x = O(x^2)$;
g) $\frac{\arctg x}{1+x^2} = O\left(\frac{1}{x^2}\right)$; d) $\ln x = o(x^e)$ ($e > 0$); e) $x^p e^{-x} = o\left(\frac{1}{x^2}\right)$;
j) $\sqrt{x + \sqrt{x + \sqrt{x}}} \sim \sqrt{x}$; z) $x^2 + x \ln^{100} x \sim x^2$.

652. Etarlicha katta $x > 0$ uchun quyidagi tengliklar o`rinli ekanligini isbotlang:

a) $x^2 + 10x + 100 < 0,001x^3$; b) $\ln^{1000} x < \sqrt{x}$; v) $x^{10} e^x < e^{2x}$.

652.1. $x \rightarrow +\infty$ da quyidagi aimptotik formulani isbotlang:

$$\sqrt{x^2 + px + q} = x + \frac{p}{2} + O\left(\frac{1}{x}\right).$$

653. $x \rightarrow 0$ bo`lsin. Quyidagi funksiyalarning Cx^n ($C = const$) ko`rinishdagi bosh hadini ajrating va x o`zgaruvchiga nisbatan kichiklik tartibini aniqlang:

a) $2x - 3x^2 + x^5$; b) $\sqrt{1+x} - \sqrt{1-x}$; v) $\sqrt{1-2x} - \sqrt[3]{1-3x}$; g) $\tg x - \sin x$.

654. $x \rightarrow 0$ bo`lsin. Ushbu

a) $f(x) = \frac{1}{\ln x}$; b) $f(x) = e^{-1/x^2}$

cheksiz kichik funksiyalarni n ning har qanday qiymatida x^n ($n > 0$) cheksiz kichik funksiya bilan taqqoslab bo`lmasligini isbotlang, ya`ni n ning hech qanday qiymatida $\lim_{x \rightarrow 0} \frac{f(x)}{x^n} = k$ tenglik o`rinli bo`lmaydi, bunda $k \neq 0$ - chekli son.

655. $x \rightarrow 1$ bo`lsin. Quyidagi funksiyalarning $C(x-1)^n$ ($C = const$) ko`rinishdagi bosh hadini ajrating va $x-1$ o`zgaruvchiga nisbatan kichiklik tartibini aniqlang:

a) $x^3 - 3x + 2$; b) $\sqrt[3]{1-\sqrt{x}}$; v) $\ln x$; g) $e^x - e$; d) $x^x - 1$.

656. $x \rightarrow +\infty$ bo`lsin. Quyidagi funksiyalarning Cx^n ($C = const$) ko`rinishdagi bosh hadini ajrating va cheksiz katta x o`zgaruvchiga nisbatan o`shish tartibini aniqlang:

a) $x^2 + 100x + 10000$; b) $\frac{2x^5}{x^3 - 3x + 1}$; v) $\sqrt[3]{x^2 - x} + \sqrt{x}$; g) $\sqrt{1 + \sqrt{1 + \sqrt{x}}}$.

657. $x \rightarrow +\infty$ bo`lsin. Quyidagi funksiyalarning $C\left(\frac{1}{x}\right)^n$ ko`rinishdagi bosh hadini ajrating va $\frac{1}{x}$ cheksiz kichik funksiya nisbatan kichiklik tartibini aniqlang:

a) $\frac{x+1}{x^4+1}$; b) $\sqrt{x+1} - \sqrt{x}$; v) $\sqrt{x+2} - 2\sqrt{x+1} + \sqrt{x}$; g) $\frac{1}{x} \sin \frac{1}{x}$.

658. $x \rightarrow 1$ bo`lsin. Quyidagi funksiyalarning $C\left(\frac{1}{x-1}\right)^n$ ko`rinishdagi bosh hadini ajrating va $\frac{1}{x-1}$ cheksiz katta funksiya nisbatan o`shish tartibini aniqlang:

a) $\frac{x^2}{x^2-1}$; b) $\sqrt{\frac{1+x}{1-x}}$; v) $\frac{x}{\sqrt[3]{1-x^3}}$; g) $\frac{1}{\sin px}$; d) $\frac{\ln x}{(1-x)^2}$.

659. $x \rightarrow +\infty$ va $f_n(x) = x^n$ ($n = 1, 2, \dots$) bo`lsin. Quyidagilarni isbotlang:

1) Har bir $f_n(x)$ funksiya o`zidan avval keladigan $f_{n-1}(x)$ funksiya nisbatan tezroq o`sadi. 2) e^x funksiya $f_n(x)$ ($n = 1, 2, \dots$) funksiyalarning har biriga nisbatan tezroq o`sadi.

660. $x \rightarrow +\infty$ va $f_n(x) = \sqrt[n]{x}$ ($n = 1, 2, \dots$) bo'lsin. Quyidagilarni isbotlang:

1) Har bir $f_n(x)$ funksiya o'zidan avval keladigan $f_{n-1}(x)$ funksiyaga nisbatan sekinroq o'sadi. 2) $f(x) = \ln x$ funksiya $f_n(x)$ ($n = 1, 2, \dots$) funksiyalarning har biriga nisbatan sekinroq o'sadi.

661. Har qanaday

$$f_1(x), f_2(x), \dots, f_n(x), \dots \quad (x_0 < x < +\infty)$$

funksiyalar ketma-ketligi uchun $x \rightarrow +\infty$ da $f_n(x)$ ($n = 1, 2, \dots$) funksiyalarning har biriga nisbatan tezroq o'sadigan $f(x)$ funksiyani qurish mumkinligini isbotlang.

7. Uzlüksiz funksiya

662. $y = f(x)$ uzlüksiz funksiya grafigi berilgan. Berilgan a nuqta va $e > 0$ son uchun $|x - a| < d$ bo'lganda $|f(x) - f(a)| < e$ shart bajariladigan $d > 0$ sonni geometrik nuqtai nazardan ko'rsating.

663. Metalldan tomoni $x_0 = 10$ sm bo'lgan kvadrat plastinka tayyorlash kerak. Bu plastinkaning $y = x^2$ yuzi uning proekti $y_0 = 100$ sm² yuzidan

a) ± 1 sm²; b) $\pm 0,1$ sm²; v) $\pm 0,01$ sm²; g) $\pm e$ sm²

ga farq qilishi uchun plastinkaning x tomonini qanday oraliqlarda o'zgartirish mumkin?

664. Kubning qirrasini 2 m va 3 m oraliqda joylashgan. Kubning y hajmini e m³ dan katta bo'lmagan absolyut xatolik bilan hisoblash uchun uning x qirrasini qanday Δ absolyut xatolik bilan o'lchash mumkin, bunda:

a) $e = 0,1$ m³; b) $e = 0,01$ m³; v) $e = 0,001$ m³?

665. $x_0 = 100$ nuqtaning qanday eng katta atrofida $y = \sqrt{x}$ funksiya grafigining ordinatasi $y_0 = 10$ ordinatadan $e = 10^{-n}$ ($n \geq 0$) ga kichik bo'ladi? Bu atrofning o'lchamlarini (kattaliklarini) $n = 0, 1, 2, 3$ larda aniqlang.

666. "e - d" tilida $f(x) = x^2$ funksiyaning $x = 5$ nuqtada uzlüksiz ekanligini isbotlang.

Quyidagi jadvalni to'ldiring:

e	1	0,1	0,01	0,001	...
d					

667. $f(x) = \frac{1}{x}$ va $e = 0,001$ bo'lsin. x_0 nuqtaning $x_0 = 0,1; 0,01; 0,001; \dots$ qiymatlari uchun $|x - x_0| < d$ tengsizlikdan $|f(x) - f(x_0)| < e$ tengsizlik kelib chiqadigan eng katta $d = d(e, x_0)$ sonlarni toping.

Berilgan $e = 0,001$ son uchun x_0 nuqtaning (0,1) oraliqdagi barcha qiymatlari uchun agar $|x - x_0| < d$ bo'lsa, $|f(x) - f(x_0)| < e$ shart bajariladigan $d > 0$ sonni tanlash mumkinmi?

668. x_0 nuqtada aniqlangan $f(x)$ funksiya shu nuqtada uzlüksiz bo'lmashlik shartini "e - d" tilida yozing.

669. Ba'zi bir $e > 0$ sonlar uchun $|x - x_0| < d$ bo'lganda $|f(x) - f(x_0)| < e$ tengsizlik bajariladigan mos $d = d(e, x_0) > 0$ sonlarni topish mumkin bo'lsin. Agar: a) e

sonlar chekli to'plamni tashkil etsa; b) e sonlar $e = \frac{1}{2^n}$ ($n = 1, 2, \dots$) ikkilik kasrlardan iborat cheksiz to'plamni tashkil etsa, $f(x)$ funksiya x_0 nuqtada uzluksiz bo'ladimi?

670. $f(x) = x + 0,001[x]$ funksiya berilgan bo'lsin. Har qanday $e > 0,001$ son uchun $|x' - x| < d$ bo'lganda $|f(x') - f(x)| < e$ tengsizlik bajariladigan $d = d(e, x_0) > 0$ sonni tanlash mumkinligini, har qanday $0 < e < 0,001$ son uchun esa x ning barcha qiymatlari uchun buni qilish mumkin emasligini isbotlang.

Qanday nuqtalarda bu funksiyaning uzluksizligi buziladi?

671. Har qanday etarlicha kichik $d > 0$ son uchun $|x - x_0| < d$ tengsizlikdan $|f(x) - f(x_0)| < e$ tengsizlik o'rinni bo'ladigan $e = e(d, x_0) > 0$ son mavjud bo'lsin. Bundan $f(x)$ funksiyaning $x = x_0$ nuqtada uzluksizligi kelib chiqadimi? YUqoridagi tengsizliklar orqali $f(x)$ funksiyaning qanday xossasi ifodalanadi?

672. Har qanday $e > 0$ son uchun $|f(x) - f(x_0)| < e$ bo'lganda $|x - x_0| < d$ shart bajariladigan $d = d(e, x_0)$ son mavjud bo'lsin. Bundan $f(x)$ funksiyaning $x = x_0$ nuqtada uzluksizligi kelib chiqadimi? YUqoridagi tengsizliklar orqali $f(x)$ funksiyaning qanday xossasi ifodalanadi?

673. Har qanday etarlicha kichik $d > 0$ son uchun $|f(x) - f(x_0)| < e$ tengsizlikdan $|x - x_0| < d$ tengsizlik o'rinni bo'ladigan $e = e(d, x_0) > 0$ son mavjud bo'lsin. Bundan $f(x)$ funksiyaning $x = x_0$ nuqtada uzluksizligi kelib chiqadimi? YUqoridagi tengsizliklar orqali $f(x)$ funksiyaning qanday xossasi ifodalanadi?

Quyidagi misolni ko'ring: $f(x) = \begin{cases} \arctg x, & \text{agar } x \text{ raqional b'ulsa,} \\ p - \arctg x, & \text{agar } x \text{ irraqional b'ulsa.} \end{cases}$

674. Quyidagi funksiylarning uzluksizligini " $e - d$ " tilida isbotlang:

a) $ax + b$; b) x^2 ; v) x^3 ; g) \sqrt{x} ; d) $\sqrt[3]{x}$; e) $\sin x$
j) $\cos x$; z) $\arctg x$.

Quyidagi funksiylarning uzluksizligini aniqlang va grafigini tasvirlang (675-686):

675. $f(x) = |x|$.

676. $f(x) = \begin{cases} \frac{x^2 - 4}{x - 2}, & \text{agar } x \neq 2; \\ A, & \text{agar } x = 2. \end{cases}$

677. Agar $x \neq -1$ bo'lsa, $f(x) = \frac{1}{(1+x)^2}$ va $f(-1)$ - ixtiyoriy son.

678. a) Agar $x \neq 0$ bo'lsa, $f_1(x) = \left| \frac{\sin x}{|x|} \right|$ va $f_1(0) = 1$;

b) Agar $x \neq 0$ bo'lsa, $f_2(x) = \frac{\sin x}{|x|}$ va $f_2(0) = 1$.

679. Agar $x \neq 0$ bo'lsa, $f(x) = \sin \frac{1}{x}$ va $f(0)$ - ixtiyoriy son.

680. Agar $x \neq 0$ bo'lsa, $f(x) = x \sin \frac{1}{x}$ va $f(0) = 0$.

681. Agar $x \neq 0$ bo'lsa, $f(x) = e^{-1/x^2}$ va $f(0) = 0$.

682. Agar $x \neq 1$ bo'lsa, $f(x) = \frac{1}{1+e^{1/x-1}}$ va $f(1)$ - ixtiyoriy son.

683. Agar $x \neq 0$ bo'lsa, $f(x) = x \ln x^2$ va $f(0) = a$.

684. $f(x) = \operatorname{sgn} x$.

685. $f(x) = [x]$.

686. $f(x) = \sqrt{x} - [\sqrt{x}]$.

Quyidagi funksiyalarning uzilish nuqtalari va ularning turini aniqlang (687-700):

$$687. y = \frac{x}{(1+x)^2}.$$

$$688. y = \frac{1+x}{1+x^3}.$$

$$689. y = \frac{x^2-1}{x^3-3x+2}.$$

$$690. y = \frac{\frac{1}{x} - \frac{1}{x+1}}{\frac{1}{x-1} - \frac{1}{x}}.$$

$$691. y = \frac{x}{\sin x}.$$

$$692. y = \sqrt{\frac{1-\cos px}{4-x^2}}.$$

$$693. y = \cos^2 \frac{1}{x}.$$

$$694. y = \operatorname{sgn} \left(\sin \frac{p}{x} \right).$$

$$695. y = \frac{\cos \frac{p}{x}}{\cos \frac{p}{x}}.$$

$$696. y = \operatorname{arctg} \frac{1}{x}.$$

$$697. y = \sqrt{x} \operatorname{arctg} \frac{1}{x}.$$

$$698. y = e^{x+1/x}.$$

$$699. y = \frac{1}{\ln x}.$$

$$700. y = \frac{1}{1-e^{x/1-x}}.$$

Quyidagi funksiyalarni uzluksizlikka tekshiring va grafiklarining eskizini chizing (701-719):

$$701. y = \operatorname{sgn}(\sin x).$$

$$702. y = x - [x].$$

$$703. y = x[x].$$

$$704. y = [x] \sin px.$$

$$705. y = x^2 - [x^2].$$

$$706. y = \left[\frac{1}{x} \right].$$

$$707. y = x \left[\frac{1}{x} \right].$$

$$708. y = \operatorname{sgn} \left(\cos \frac{1}{x} \right).$$

$$709. y = \left[\frac{1}{x^2} \right] \operatorname{sgn} \left(\sin \frac{p}{x} \right).$$

$$710. y = \operatorname{ctg} \frac{p}{x}.$$

$$711. y = \sec^2 \frac{1}{x}.$$

$$712. y = (-1)^{[x^2]}.$$

$$713. y = \operatorname{arctg} \left(\frac{1}{x} + \frac{1}{x-1} + \frac{1}{x-2} \right).$$

$$714. y = \frac{1}{x^2 \sin^2 x}.$$

$$715. y = \frac{1}{\sin(x^2)}.$$

$$716. y = \ln \frac{x^2}{(x+1)(x-3)}.$$

$$717. y = e^{-1/x}.$$

$$718. y = 1 - e^{-1/x^2}.$$

$$719. y = \operatorname{th} \frac{2x}{1-x^2}.$$

Quyidagi funksiyalarni uzluksizlikka tekshiring va grafiklarini yasang (720-728):

$$720. y = \lim_{n \rightarrow \infty} \frac{1}{1+x^n} \quad (x \geq 0).$$

$$721. y = \lim_{n \rightarrow \infty} \frac{n^x - n^{-x}}{n^x + n^{-x}}.$$

$$722. y = \lim_{n \rightarrow \infty} \sqrt[n]{1+x^{2n}}.$$

$$723. y = \lim_{n \rightarrow \infty} \cos^{2n} x.$$

$$724. y = \lim_{n \rightarrow \infty} \frac{x}{1+(2 \sin x)^{2n}}.$$

$$725. y = \lim_{n \rightarrow \infty} [x \operatorname{arctg}(n \operatorname{ctg} x)].$$

$$726. y = \lim_{n \rightarrow \infty} \frac{x+x^2 e^{nx}}{1+e^{nx}}.$$

$$727. y = \lim_{t \rightarrow +\infty} \frac{\ln(1+e^{xt})}{\ln(1+e^t)}.$$

$$728. y = \lim_{t \rightarrow +\infty} (1+x) \operatorname{th} tx.$$

$$729. f(x) = \begin{cases} 2x & 0 \leq x \leq 1, \\ 2-x, & 1 < x \leq 2 \end{cases} \text{ funksiya uzluksiz bo`ladimi?}$$

730. Ushbu

$$f(x) = \begin{cases} e^x, & x < 0, \\ a+x, & x \geq 0 \end{cases}$$

funksiya a sonning qanday qiymatida uzluksiz bo`ladi?

731. Quyidagi funksiyalarning uzilish nuqtalari va ularning turini aniqlang:

$$a) f(x) = \begin{cases} x^2, & 0 \leq x \leq 1, \\ 2-x, & 1 < x \leq 2; \end{cases} \quad b) f(x) = \begin{cases} x, & |x| \leq 1, \\ 1, & |x| > 1; \end{cases}$$

$$v) f(x) = \begin{cases} \cos \frac{px}{2}, & |x| \leq 1, \\ |x-1|, & |x| > 1; \end{cases} \quad g) f(x) = \begin{cases} \operatorname{ctg}^2 px, & x \notin Z, \\ 0, & x \in Z; \end{cases}$$

$$d) f(x) = \begin{cases} \sin px, & \text{agar } x \text{ raatsional b`ulsa,} \\ 0, & \text{agar } x \text{ irraatsional b`ulsa.} \end{cases}$$

732. $d = d(x)$ - Ox o`qining x nuqtasidan shu o`qning $0 \leq x \leq 1$ va $2 \leq x \leq 3$

kesmalaridan iborat to`plamning nuqtalari orasidagi masofani ifodalovchi funksiya bo`lsin. d funksiyaning analitik ko`rinishini toping, grafigini yasang va uzluksizlikka tekshiring.

733. E figura asosi va balandligi 1 ga teng bo`lgan teng yonli uchburchak va har birining asosi 1 ga, balandliklari mos ravishda 2 va 3 ga teng bo`lgan ikkita to`g`ri to`rtburchaklardan iborat. $S = S(y)$ ($0 \leq y < +\infty$) funksiya E figuraning $Y = 0$ va $Y = y$ parallel to`g`ri chiziqlar orasidagi qismining yuzini ifodalaydi, $b = b(y)$ ($0 \leq y < +\infty$) funksiya esa E figura bilan $Y = y$ to`g`ri chiziq kesimining uzunligini ifodalaydi. S va b funksiyalarning analitik ko`rinishlarini toping, grafklarini yasang va uzluksizlikka tekshiring (5-rasm).

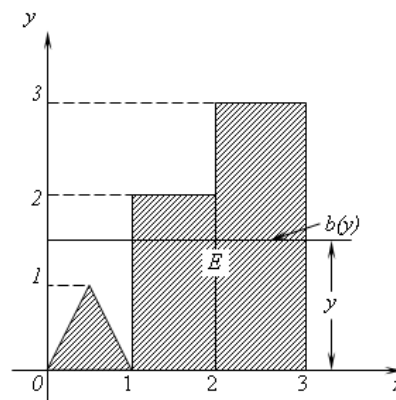

5-рasm

734. Ushbu

$$c(x) = \lim_{m \rightarrow \infty} \left\{ \lim_{n \rightarrow \infty} \cos^n \right\} (pm!x)$$

Dirixle funksiyasi x ning har bir qiymatida uzilishga ega ekanligini isbotlang.

735. Quyidagi funksiyani uzluksizlikka tekshiring:

$$f(x) = xc(x),$$

bunda $c(x)$ - Dirixle funksiyasi. Bu funksiya grafigining eskizini yasang.

736. Ushbu

$$f(x) = \begin{cases} \frac{1}{n}, & \text{agar } x = \frac{m}{n} \text{ b`ulsa, bunda } m \text{ va } n \text{ u`zaro tub sonlar;} \\ 0, & \text{agar } x \text{ irraatsional son b`ulsa,} \end{cases}$$

Riman funksiyasi x ning barcha ratsional qiymatlarida uzilishga ega va barcha irratsional qiymatlarida esa uzluksiz ekanligini isbotlang. Bu funksiya grafigining eskizini yasang.

737. Quyidagi funksiyani uzluksizlikka tekshiring:

$$f(x) = \begin{cases} \frac{nx}{n+1}, & \text{agar } x = \frac{m}{n} \text{ kiskarmas raatsional kasr b`ulsa, bunda } n \geq 1; \\ |x|, & \text{agar } x \text{ irraatsional son b`ulsa.} \end{cases}$$

Bu funksiya grafigining eskizini chizing.

738. $f(x) = \frac{1 - \cos x}{x^2}$ funksiya x ning $x = 0$ dan boshqa barcha qiymatlarida aniqlangan.

Bu funksiya $x = 0$ nuqtada uzluksiz bo`lishi uchun $f(0)$ ni qanday tanlash kerak?

739. $f(1)$ sonni har qanday tanlanganda ham $f(x) = \frac{1}{1-x}$ funksiya $x = 1$ nuqtada uzilishga ega bo`lishini isbotlang.

740. $f(x)$ funksiya $x = 0$ nuqtada ma`noga ega emas. $f(0)$ sonni shunday tanlangi, $f(x)$ funksiya $x = 0$ nuqtada uzluksiz bo`lsin:

a) $f(x) = \frac{\sqrt{1+x}-1}{\sqrt[3]{1+x}-1}$; b) $f(x) = \frac{\operatorname{tg} 2x}{x}$; v) $f(x) = \sin x \sin \frac{1}{x}$;

g) $f(x) = (1+x)^{1/x}$; d) $f(x) = \frac{1}{x^2} e^{-1/x^2}$; e) $f(x) = x^x \ (x > 0)$;

j) $f(x) = x \ln^2 x$.

741. Agar: a) $f(x)$ funksiya $x = x_0$ nuqtada uzluksiz, $g(x)$ funksiya esa $x = x_0$ nuqtada uzilishga ega; b) ikkala $f(x)$ va $g(x)$ funksiyalar $x = x_0$ nuqtada uzilishga ega bo`lsa, u holda $f(x) + g(x)$ funksiya $x = x_0$ nuqtada, albatta, uzilishga ega bo`ladimi? Har bir hol misol keltiring.

742. Agar: a) $f(x)$ funksiya $x = x_0$ nuqtada uzluksiz, $g(x)$ funksiya esa $x = x_0$ nuqtada uzilishga ega; b) ikkala $f(x)$ va $g(x)$ funksiyalar $x = x_0$ nuqtada uzilishga ega bo`lsa, u holda $f(x)g(x)$ funksiya $x = x_0$ nuqtada, albatta, uzilishga ega bo`ladimi? Har bir hol misol keltiring.

743. Uzilishga ega funksiyaning kvadrati ham uzilishga ega bo`ladi deb tasdiqlash mumkinmi?

744. Agar:

a) $f(x) = \operatorname{sgn} x$, $g(x) = 1 + x^2$; b) $f(x) = \operatorname{sgn} x$, $g(x) = x(1 - x^2)$;

v) $f(x) = \operatorname{sgn} x$, $g(x) = 1 + x - [x]$

bo`lsa, $f[g(x)]$ va $g[f(x)]$ funksiyalarni uzluksizlikka tekshiring.

745. Agar

$$f(u) = \begin{cases} u, & \text{agar } 0 < u \leq 1 \text{ бўлса;} \\ 2-u, & \text{agar } 1 < u < 2 \text{ бўлса} \end{cases}$$

va

$$j(x) = \begin{cases} x, & \text{agar } x \text{ рационал бўлса;} \\ 2-x, & \text{agar } x \text{ иррационал бўлса} \end{cases} \quad (0 < x < 1)$$

bo`lsa, u holda $y = f(u)$ murakkab funksiyani uzluksizlikka tekshiring, bunda $u = j(x)$.

746. Agar $f(x)$ funksiya uzluksiz bo`lsa, u holda $F(x) = |f(x)|$ funksiya ham uzluksiz bo`lishini isbotlang.

747. Agar $f(x)$ funksiya uzluksiz bo`lsa, u holda

$$f_c(x) = \begin{cases} -c, & \text{agar } f(x) < -c \text{ бўлса;} \\ f(x), & \text{agar } |f(x)| \leq c \text{ бўлса;} \\ c, & \text{agar } f(x) > c \text{ бўлса} \end{cases}$$

funksiya ham uzluksiz bo`lishini isbotlang, bunda c - ixtiyoriy musbat son.

748. Agar $f(x)$ funksiya $[a, b]$ kesmada uzluksiz bo`lsa, u holda

$$m(x) = \inf_{a \leq x \leq b} \{f(x)\} \quad \text{va} \quad M(x) = \sup_{a \leq x \leq b} \{f(x)\}$$

Funksiyalar ham $[a, b]$ kesmada uzluksiz bo`lishini isbotlang.

749. Agar $f(x)$ va $g(x)$ funksiyalar uzluksiz bo`lsa, u holda

$$j(x) = \min[f(x), g(x)] \quad \text{va} \quad y(x) = \max[f(x), g(x)]$$

funksiyalar ham uzluksiz bo`lishini isbotlang.

750. $f(x)$ funksiya $[a, b]$ kesmada aniqlangan va chegaralangan funksiya bo`lsin. U holda

$$m(x) = \inf_{a \leq x < b} \{f(x)\} \quad \text{va} \quad M(x) = \sup_{a \leq x < b} \{f(x)\}$$

funksiyalar $[a, b]$ kesmada chapdan uzluksiz ekanligini isbotlang.

751. Agar $f(x)$ funksiya $a \leq x < +\infty$ oraliqda uzluksiz va $\lim_{x \rightarrow +\infty} f(x)$ chekli limit mavjud bo`lsa, u holda bu funksiya berilgan oraliqda chegaralangan ekanligini isbotlang.

752. $f(x)$ funksiya $(x_0, +\infty)$ oraliqda uzluksiz va chegaralangan bo`lsin. U holda har qanday T son uchun

$$\lim_{n \rightarrow \infty} [f(x_n + T) - f(x_n)] = 0$$

tenglik bajariladigan $x_n \rightarrow +\infty$ ketma-ketlik mavjudligini isbotlang.

753. $j(x)$ va $y(x)$ funksiyalar $-\infty < x < +\infty$ oraliqda aniqlangan uzluksiz, davriy funksiyalar va

$$\lim_{x \rightarrow +\infty} [j(x) - y(x)] = 0$$

tenglik o`rinli bo`lsin. U holda $j(x) = y(x)$ bo`lishini isbotlang.

754. Chegaralangan monoton funksiyaning barcha uzilish nuqtalari 1-tur uzilish nuqtalari bo`lishini isbotlang.

755. Agar $f(x)$ funksiya $[a, b]$ kesmada monoton va chegaralangan va $f(a)$ va $f(b)$ sonlar orasidagi barcha sonlar uning qiymatlari bo`lsa, u holda $f(x)$ funksiya $[a, b]$ kesmada uzluksiz ekanligini isbotlang.

756. Ushbu

$$f(x) = \begin{cases} \sin \frac{1}{x-a}, & \text{agar } x \neq a \text{ bo`lsa;} \\ 0, & \text{agar } x = a \text{ bo`lsa} \end{cases}$$

funksiyaning qiymatlari ixtiyoriy $[a, b]$ kesmada $f(a)$ va $f(b)$ sonlar orasidagi barcha sonlardan iborat ekanligini, lekin $f(x)$ funksiya $[a, b]$ kesmada uzluksiz emasligini isbotlang.

757. Isbotlang: agar $f(x)$ funksiya (a, b) oraliqda uzluksiz bo`lsa, u holda shu oraliqdan olingan ixtiyoriy x_1, x_2, \dots, x_n qiymatlar orasida yotuvchi shunday x son topiladiki,

$$f(x) = \frac{1}{n} [f(x_1) + f(x_2) + \dots + f(x_n)]$$

tenglik o`rinli bo`ladi.

758. $f(x)$ funksiya (a, b) oraliqda uzluksiz va

$$l = \underline{\lim}_{x \rightarrow a} f(x), \quad L = \overline{\lim}_{x \rightarrow a} f(x)$$

bo`lsin. U holda har qanday I ($l \leq I \leq L$) son uchun

$$\lim_{n \rightarrow \infty} f(x_n) = I$$

tenglik bajariladigan $x_n \rightarrow a$ ($n = 1, 2, \dots$) ketma-ketlik mavjudligini isbotlang.

8. Teskari funksiya. Parametrik berilgan funksiya.

759. Ushbu

$$y = \frac{ax+b}{cx+d} \quad (ad - bc \neq 0)$$

kasr-chiziqli funksiyaga teskari funksiyani toping. Qanday holda teskari funksiya berilgan funksiya bilan ustma-ust tushadi?

760. $y = x + [x]$ funksiya uchun $x = x(y)$ teskari funksiyani toping.

761. Ushbu

$$y - e \sin y = x \quad (0 \leq e < 1)$$

Kepler tenglamasini qanoatlantiruvchi yagona $y = y(x)$ ($-\infty < x < +\infty$) uzluksiz funksiya mavjudligini isbotlang.

762. $\operatorname{ctg} x = kx$ tenglama har qanday haqiqiy k ($-\infty < k < +\infty$) son uchun $0 < x < p$ oraliqda yagona uzluksiz $x = x(k)$ ildizga ega ekanligini isbotlang.

763. Monoton bo'lmagan $y = f(x)$ ($-\infty < x < +\infty$) funksiya bir qiymatli teskari funksiyaga ega bo'lishi mumkinmi? Quyidagi misolni ko'ring:

$$y = \begin{cases} x, & \text{agar } x \text{ raatsional b'ylsa;} \\ -x, & \text{agar } x \text{ irraatsional b'ylsa.} \end{cases}$$

764. Qanday holda $y = f(x)$ funksiya va $x = f^{-1}(y)$ teskari funksiyalar bitta funksiyani ifodalaydi?

765. Uzilishga ega bo'lgan $y = (1+x^2) \operatorname{sgn} x$ funksiyaga teskari bo'lgan funksiya uzluksiz ekanligini isbotlang.

766. Agar $[a, b]$ kesmada aniqlangan $f(x)$ funksiya shu kesmada qat'iy o'suvchi va

$$\lim_{n \rightarrow \infty} f(x_n) = f(a) \quad (a \leq x_n \leq b)$$

bo'lsa, u holda

$$\lim_{n \rightarrow \infty} x_n = a$$

tenglikni isbotlang.

Quyidagi funksiyalar uchun teskari funksiyaning bir qiymatli uzluksiz yaroq-larini aniqlang:

767. $y = x^2$.

768. $y = 2x - x^2$.

769. $y = \frac{2x}{1+x^2}$.

770. $y = \sin x$.

771. $y = \cos x$.

772. $y = \operatorname{tg} x$.

773. Uzluksiz $y = 1 + \sin x$ funksiyaning ($0 < x < 2p$) oraliqdagi qiymatlari to'plami kesmadan iborat ekanligini isbotlang.

774. Quyidagi tenglikni isbotlang:

$$\arcsin x + \arccos x = \frac{p}{2}.$$

775. Quyidagi tenglikni isbotlang:

$$\operatorname{arctg} x + \operatorname{arctg} \frac{1}{x} = \frac{p}{2} \operatorname{sgn} x \quad (x \neq 0).$$

776. Quyidagi arktangenslarni qo`shish teoremasini isbotlang:

$$\operatorname{arctg} x + \operatorname{arctg} y = \operatorname{arctg} \frac{x+y}{1-xy} + e p,$$

bunda $e = e(x, y)$ funksiya $0, 1, -1$ qiymatlardan birini qabul qiladi.

x ning berilgan qiymati uchun y ning qanday qiymatlarida e funksiya uzilishga ega? Oxy tekislikda e funksiya uzluksiz bo`ladigan sohalarni quring va qurilgan sohalarda bu funksiyaning qiymatlarini aniqlang.

777. Quyidagi arksinuslarni qo`shish teoremasini isbotlang:

$$\arcsin x + \arcsin y = (-1)^e \arcsin \left(x\sqrt{1-y^2} + y\sqrt{1-x^2} \right) + e p$$

$$(|x| \leq 1, |y| \leq 1),$$

bunda

$$e = \begin{cases} 0, & \text{agap } xy \leq 0 \text{ ёки } x^2 + y^2 \leq 1 \text{ бўлса,} \\ \operatorname{sgn} x, & \text{agap } xy > 0 \text{ ва } x^2 + y^2 > 1 \text{ бўлса.} \end{cases}$$

778. Quyidagi arkkosinuslarni qo`shish teoremasini isbotlang:

$$\arccos x + \arccos y = (-1)^e \arccos \left(xy - \sqrt{1-x^2} \sqrt{1-y^2} \right) + 2pe, \quad (|x| \leq 1, |y| \leq 1),$$

bunda

$$e = \begin{cases} 0, & \text{agap } x + y \geq 0, \\ 1, & \text{agap } x + y < 0. \end{cases}$$

779. Funksiyalarning grafigini yasang:

a) $y = \arcsin x - \arcsin \sqrt{1-x^2}$; b) $y = \arcsin \left(2x\sqrt{1-x^2} \right) - 2\arcsin x$.

780. Ushbu

$$x = \operatorname{arctg} t, \quad y = \operatorname{arcctg} t \quad (-\infty < t < +\infty)$$

tenglamalar bilan berilgan $y = y(x)$ funksiyani toping. Bu funksiya qanday sohada aniqlangan?

781. $x = ch t, y = sh t \quad (-\infty < t < +\infty)$ bo`lsin. t parametrining qanday qiymatlarida y funksiyani x o`zgaruvchiga nisbatan bir qiymatli funksiya deb olish mumkin? Turli sohalar uchun y ning ko`rinishlarini toping.

782. Ushbu

$$x = j(t), \quad y = y(t) \quad (a < t < b)$$

tenglamalar sistemasining echimi bir qiymatli $y = y(x)$ funksiya bo`lishining zaruriy va etarli shartlari qanday?

Quyidagi misolni ko`ring: $x = \sin^2 t, y = \cos t^2$.

783. Qanday shartlar bajarilganda ikkita

$$x = j(t), \quad y = y(t) \quad (a < t < b)$$

va

$$x = j(c(t)), \quad y = y(c(t)) \quad (a < t < b)$$

tenglamalar sistemasi bitta $y = y(x)$ funksiyani aniqlaydi?

784. (a, b) oraliqda aniqlangan $j(x)$ va $y(x)$ funksiyalar shu oraliqda uzluksiz va

$$A = \inf_{a < x < b} j(x), \quad B = \sup_{a < x < b} j(x)$$

bo`lsin. Qanday holda (A, B) oraliqda aniqlangan va $a < x < b$ oraliqda

$$j(x) = f(j(x))$$

tenglikni qanoatlantiruvchi bir qiymatli $f(x)$ mavjud?

9. Tekis uzluksiz funksiya

785. TSexda tomoni x sm bo'lgan ($1 \leq x \leq 10$) kvadrat plastinkalar ishlab chiqariladi. Bu plastinkalarning y yuzi ularning loyihasi yuzidan e dan kichik songa farq qilishi uchun tomonlarini, berilgan oraliqda uzunliklariga bog'liq bo'lmagan holda, qanday d qo'yim bilan qayta ishlash mumkin? Agar:

a) $e = 1 \text{ sm}^2$; b) $e = 0,01 \text{ sm}^2$; v) $e = 0,0001 \text{ sm}^2$

bo'lsa, sonli hisobni bajaring.

786. Kengligi e ga va uzunligi d ga teng tsilindrik mufta $y = \sqrt[3]{x}$ chiziqqa kiydirilgan va bu mufta o'zining o'qi Ox o'qiga parallel bo'lgan holatda chiziq bo'ylab sirpanib harakatlanmoqda. Agar: a) $e = 1$; b) $e = 0,1$; v) $e = 0,01$; g) e ixtiyoriy kichik son bo'lsa, bu mufta egri chiziqning $-10 \leq x \leq 10$ tengsizlik bilan aniqlanadigan qismini erkin bosib o'tishi uchun d nimaga teng bo'lishi kerak?

787. Quyidagi tasdiqni " $e - d$ " tilida ifodalang: $f(x)$ funksiya biror to'plamda (intervalda, kesmada va hokazo) uzluksiz, lekin bu to'plamda tekis uzluksiz emas.

788. $f(x) = \frac{1}{x}$ funksiya $(0, 1)$ intervalda uzluksiz, lekin shu intervalda tekis uzluksiz emasligini isbotlang.

789. $f(x) = \sin \frac{p}{x}$ funksiya $(0, 1)$ intervalda uzluksiz va chegaralangan, lekin shu intervalda tekis uzluksiz emasligini isbotlang.

790. $f(x) = \sin x^2$ funksiya $-\infty < x < +\infty$ cheksiz intervalda uzluksiz va chegaralangan, lekin shu intervalda tekis uzluksiz emasligini isbotlang.

791. Agar $f(x)$ funksiya $a < x < +\infty$ sohada aniqlangan va uzluksiz va $\lim_{x \rightarrow +\infty} f(x)$ chekli limit mavjud bo'lsa, u holda $f(x)$ funksiya shu sohada tekis uzluksiz ekanligini isbotlang.

792. CHegaranmagan $f(x) = x + \sin x$ funksiya butun sonlar o'qida ($-\infty < x < +\infty$) tekis uzluksiz ekanligini isbotlang.

793. $f(x) = x^2$ funksiya

a) $(-l, l)$, bunda l etarlicha katta ixtiyoriy musbat son; b) $-\infty < x < +\infty$

intervalda tekis uzluksiz bo'ladimi?

Quyidagi funksiyalarni ko'rsatilgan sohalarda tekis uzluksizlikka tekshiring (794-800):

794. $f(x) = \frac{x}{4-x^2}$ ($-1 \leq x \leq 1$).

795. $f(x) = \ln x$ ($0 < x < 1$).

796. $f(x) = \frac{\sin x}{x}$ ($0 < x < p$).

797. $f(x) = e^x \cos \frac{1}{x}$ ($0 < x < 1$).

798. $f(x) = \arctg x$ ($-\infty < x < +\infty$).

799. $f(x) = \sqrt{x}$ ($1 \leq x < +\infty$).

800. $f(x) = x \sin x$ ($0 \leq x < +\infty$).

801. $f(x) = \frac{|\sin x|}{x}$ funksiya $J_1 = (-1 < x < 0)$ va $J_2 = (0 < x < 1)$ intervallarning har birida

tekis yaqinlashuvchi, lekin $J_1 + J_2 = \{0 < |x| < 1\}$ intervalda tekis yaqinlashuvchi emasligini isbotlang.

801.1. Agar $f(x)$ funksiya $[a, c]$ va $[c, b]$ kesmalarning har birida tekis yaqinlashuvchi bo`lsa, u holda bu funksiya $[a, b] = [a, c] \cup [c, b]$ kesmada ham tekis yaqinlashuvchi bo`lishini isbotlang.

802. Agar:

a) $f(x) = 5x - 3$ ($-\infty < x < +\infty$); b) $f(x) = x^2 - 2x - 1$ ($-2 \leq x \leq 5$);

v) $f(x) = \frac{1}{x}$ ($0,1 \leq x \leq 1$); g) $f(x) = \sqrt{x}$ ($0 \leq x < +\infty$);

d) $f(x) = 2 \sin x - \cos x$ ($-\infty < x < +\infty$);

e) $f(x) = x \sin \frac{1}{x}$ ($x \neq 0$) va $f(0) = 0$ ($0 \leq x \leq p$).

bo`lsa, ixtiyoriy $\epsilon > 0$ son uchun $f(x)$ funksiyaning berilgan oraliqda tekis uzluksizlik shartlarini qanoatlantiruvchi $d = d(\epsilon)$ (biror!) sonni toping.

803. $f(x) = x^2$ funksiyaning tebranishi har bir bo`lingan kesmada 0,0001 dan kichik bo`lishi uchun $[1, 10]$ kesmani nechta bir-biriga teng kesmalarga bo`lish etarli bo`ladi? 804. (a, b) intervalda tekis uzluksiz bo`lgan chekli sondagi funksiyalarning yig`indisi va ko`paytmasi ham shu intervada tekis uzluksiz bo`lishini isbotlang.

805. Agar monoton va chegaralangan $f(x)$ funksiya chekli yoki cheksiz (a, b) intervalda uzluksiz bo`lsa, u holda bu funksiya (a, b) intervalda tekis uzluksiz bo`lishini isbotlang.

806. Agar $f(x)$ funksiya chekli (a, b) intervalda tekis uzluksiz bo`lsa, u holda ushbu

$$A = \lim_{x \rightarrow a+0} f(x) \quad \text{va} \quad B = \lim_{x \rightarrow b-0} f(x)$$

limitlar mavjud. Agar (a, b) interval cheksiz bo`lsa, teorema o`rinli bo`ladimi?

806.1. Chekli (a, b) intervalda aniqlangan va uzluksiz $f(x)$ funksiyaning uzluksiz ravishda $[a, b]$ kesmaga davom ettirish uchun $f(x)$ funksiya (a, b) intervalda tekis uzluksiz bo`lishi zarur va etarli ekanligini isbotlang.

807. (a, b) intervalda $f(x)$ funksiyaning uzluksizlik moduli deb

$$w_f(d) = \sup |f(x_1) - f(x_2)|$$

funksiyaga aytiladi, bunda x_1 va x_2 lar $|x_1 - x_2| \leq d$ shartni qanoatlantiruvchi (a, b) intervaldagi ixtiyoriy nuqtalar.

$f(x)$ funksiyaning (a, b) oraliqda tekis uzluksiz bo`lishi uchun

$$\lim_{d \rightarrow 0} w_f(d) = 0$$

tenglik bajarilishi zarur va etarli ekanligini isbotlang.

808. Agar:

a) $f(x) = x^3$ ($0 \leq x \leq 1$);

b) $f(x) = \sqrt{x}$ ($0 \leq x \leq a$) va ($a < x < +\infty$);

v) $f(x) = \sin x + \cos x$ ($0 \leq x \leq 2p$)

bo`lsa,

$$w_f(d) \leq Cd^a$$

ko`rinishdagi $w_f(d)$ uzluksizlik modulning bahosini toping, bunda C va a - o`zgarmas sonlar.

10. Funktsional tenglamalar

809. x va y ning barcha haqiqiy qiymatlarida

$$f(x+y) = f(x) + f(y) \quad (1)$$

tenglamani qanoatlantiruvchi yagona uzluksiz $f(x)$ ($-\infty < x < +\infty$) funksiya $f(x) = ax$ ko`rinishdagi chiziqli bir jinsli funksiya ekanligini isbotlang, bunda $a = f(1)$ - ixtiyoriy o`zgarmas son.

810. (1) tenglamani qanoatlantiruvchi monoton $f(x)$ funksiya chiziqli bir jinsli ekanligini isbotlang.

811. (1) tenglamani qanoatlantiruvchi va etarlicha kichik $(-e, e)$ intervalda chegaralangan $f(x)$ funksiya chiziqli bir jinsli ekanligini isbotlang.

812. x va y ning barcha qiymatlarida

$$f(x+y) = f(x)f(y) \quad (2)$$

tenglamani qanoatlantiruvchi yagona nolga aynan teng bo`lmagan uzluksiz $f(x)$ ($-\infty < x < +\infty$) funksiya $f(x) = a^x$ ko`rsatkichli funksiya ekanligini isbotlang, bunda $a = f(1)$ - musbat o`zgarmas son.

813. (2) tenglamani qanoatlantiruvchi, nolga aynan teng bo`lmagan va $(0, e)$ intervalda chegaralangan $f(x)$ funksiya ko`rsatkichli funksiya ekanligini isbotlang.

814. x va y ning barcha musbat qiymatlarida

$$f(xy) = f(x) + f(y)$$

tenglamani qanoatlantiruvchi yagona nolga aynan teng bo`lmagan uzluksiz $f(x)$ ($0 < x < +\infty$) funksiya $f(x) = \log_a x$ logarifmik funksiya ekanligini isbotlang, bunda a - musbat o`zgarmas son ($a \neq 1$).

815. x va y ning barcha musbat qiymatlarida

$$f(xy) = f(x)f(y) \quad (3)$$

tenglamani qanoatlantiruvchi yagona nolga aynan teng bo`lmagan uzluksiz $f(x)$ ($0 < x < +\infty$) funksiya $f(x) = x^a$ darajali funksiya ekanligini isbotlang, bunda a - o`zgarmas son.

816. x va y ning barcha haqiqiy qiymatlarida (3) tenglamani qanoatlantiruvchi barcha uzluksiz $f(x)$ ($-\infty < x < +\infty$) funksiyalarni toping.

817. Uzilishga ega $f(x) = \operatorname{sgn} x$ funksiya (3) tenglamani qanoatlantirishini isbotlang.

818. x va y ning barcha haqiqiy qiymatlarida

$$f(x+y) + f(x-y) = 2f(x)f(y)$$

tenglamani qanoatlantiruvchi barcha uzluksiz $f(x)$ ($-\infty < x < +\infty$) funksiyalarni toping.

819. x va y ning barcha haqiqiy qiymatlarida

$$f(x+y) = f(x)f(y) - g(x)g(y)$$

$$g(x+y) = f(x)g(y) + f(y)g(x)$$

tenglamalar sistemasini va

$$f(0) = 1, \quad g(0) = 0$$

shartlarni qanoatlantiruvchi barcha uzluksiz chegaralangan $f(x)$ va $g(x)$ ($-\infty < x < +\infty$) funksiyalarni toping.

Y o`ll a n m a. $F(x) = f^2(x) + g^2(x)$ funksiyani ko`ring.

820. $\Delta f(x) = f(x + \Delta x) - f(x)$ va $\Delta^2 f(x) = \Delta\{\Delta f(x)\} - f(x)$ funksiyaning mos ravishda birinchi va ikkinchi tartibli chekli ayirmalari bo`lsin.

Agar $f(x)$ ($-\infty < x < +\infty$) funksiya uzluksiz va $\Delta^2 f(x) \equiv 0$ bo`lsa, u holda bu funksiya chiziqli ekanligini isbotlang, ya`ni $f(x) = ax + b$, bunda a va b - o`zgarmas sonlar.

II-BO`LIM

BIR O`ZGARUVCHILI FUNKSIYANING DIFFERENSIAL HISOBI

1. Funksiya hosilasi

821. Agar x o`zgaruvchi 1 dan 1000 gacha o`zgarsa, $y = \lg x$ funksiyaning x argumentining Δx orttirmasi va unga mos Δy funksiya orttirmasini aniqlang.

822. Agar x o`zgaruvchi 0,01 dan 0,001 gacha o`zgarsa, $y = 1/x^2$ funksiyaning x argumentining Δx orttirmasi va unga mos Δy funksiya orttirmasini aniqlang.

823. x o`zgaruvchi Δx orttirmaga ega. Agar: a) $y = ax + b$; b) $y = ax^2 + bx + c$; v) $y = a^x$ bo`lsa, Δy orttirmani aniqlang.

824. Quyidagilarni isbotlang:

a) $\Delta [f(x) + g(x)] = \Delta f(x) + \Delta g(x)$;

b) $\Delta [f(x)g(x)] = g(x + \Delta x)\Delta f(x) + f(x)\Delta g(x)$.

825. $y = x^2$ chiziqning $A(2, 4)$ va $A'(2 + \Delta x, 4 + \Delta y)$ nuqtalari orqali AA' kesuvchi o`tkazilgan. Agar: a) $\Delta x = 1$; b) $\Delta x = 0,1$; v) $\Delta x = 0,01$; g) Δx bo`lsa, bu kesuvchining burchak koeffitsientini toping.

Berilgan chiziqqa A nuqtada o`tkazilgan urinmaning burchak koeffitsienti nimaga teng?

826. Ox o`qining $1 \leq x \leq 1 + h$ kesmasi $y = x^3$ funksiya yordamida Oy o`qiga akslanadi. Cho`zilishning o`rtacha koeffitsientini hisoblang va agar: a) $h = 0,1$; b) $h = 0,01$ v) $h = 0,001$ bo`lsa, sonli hisobni bajaring.

Bu akslantirishda $x = 1$ nuqtadagi cho`zilish koeffitsienti nimaga teng?

827. Nuqtaning Ox o`qi bo`yicha harakati ushbu

$$x = 10t + 5t^2$$

formula bilan ifodalanadi. Harakatning $20 \leq t \leq 20 + \Delta t$ vaqt oralig`idagi o`rtacha tezligi-ni toping va agar: a) $\Delta t = 1$; b) $\Delta t = 0,1$; v) $\Delta t = 0,01$ bo`lganda sonli hisobni bajaring. Harakatning $t = 20$ vaqt momentidagi tezligi nimaga teng?

828. Hosilaning ta`rifidan foydalanib, quyidagi funksiyalarning hosilalarini toping:

a) x^2 ; b) x^3 ; v) $\frac{1}{x}$; g) \sqrt{x} ; d) $\sqrt[3]{x}$;

e) $tg x$; j) $ctg x$; z) $\arcsin x$; i) $\arccos x$; k) $arctg x$.

829. $f'(x) = (x-1)(x-2)^2(x-3)^3$ funksiya uchun $f'(1)$, $f'(2)$ va $f'(3)$ larni toping.

830. $f(x) = x^2 \sin(x-2)$ funksiya uchun $f'(2)$ ni toping.

831. Agar

$$f(x) = x + (x-1)\arcsin\sqrt{\frac{x}{x+1}}$$

bo`lsa, $f'(1)$ ni toping.

832. Agar $f(x)$ funksiya a nuqtada differensiallanuvchi bo`lsa, u holda

$$\lim_{x \rightarrow a} \frac{f(x) - f(a)}{x - a}$$

limitni toping.

833. Agar $f(x)$ funksiya differensiallanuvchi va n - natural son bo`lsa, u holda

$$\lim_{n \rightarrow \infty} n \left[f \left(x + \frac{1}{n} \right) - f(x) \right] = f'(x) \quad (1)$$

tenglik o`rinli ekanligini isbotlang.

Agar $f(x)$ funksiya uchun (1) limit mavjud bo`lsa, u holda bu funksiya hosilaga ega bo`ladimi? Misol sifatida Dirixle funksiyasini ko`ring(734-misol).

Hosila jadvalidan foydalanib, quyidagi funksiyalarning hosilalarini toping (834-843):

834. $y = 2 + x - x^2$.

$$y'(0); y'\left(\frac{1}{2}\right); y'(1); y'(-10) \text{ lar nimaga teng?}$$

835. $y = \frac{x^3}{3} + \frac{x^2}{2} - 2x$.

x ning qanday qiymatlarida: a) $y'(x) = 0$; b) $y'(x) = -2$; v) $y'(x) = 10$?

836. $y = a^5 + 5a^3x^2 - x^5$.

837. $y = \frac{ax+b}{a+b}$.

838. $y = (x-a)(x-b)$.

839. $y = (x+1)(x+2)^2(x+3)^3$.

840. $y = (x \sin a + \cos a)(x \cos a - \sin a)$.

841. $y = (1 + nx^m)(1 + mx^n)$.

842. $y = (1-x)(1-x^2)^2(1-x^3)^3$.

842.1. $y = (5+2x)^{10}(3-4x)^{20}$.

843. $y = \frac{1}{x} + \frac{2}{x^2} + \frac{3}{x^3}$.

844. Quyidagi formulani isbotlang:

$$\left(\frac{ax+b}{cx+d} \right)' = \frac{\begin{vmatrix} a & b \\ c & d \end{vmatrix}}{(cx+d)^2}$$

Quyidagi funksiyalarning hosilalarini toping (845-971):

845. $y = \frac{2x}{1-x^2}$.

846. $y = \frac{1+x-x^2}{1-x+x^2}$.

847. $y = \frac{x}{(1-x)^2(1+x)^3}$.

848. $y = \frac{(2-x^2)(2-x^3)}{(1-x)^2}$.

849. $y = \frac{(1-x)^p}{(1+x)^q}$.

850. $y = \frac{x^p(1-x)^q}{1+x}$.

851. $y = x + \sqrt{x} + \sqrt[3]{x}$.

852. $y = \frac{1}{x} + \frac{1}{\sqrt{x}} + \frac{1}{\sqrt[3]{x}}$.

853. $y = \sqrt[3]{x^2} - \frac{2}{\sqrt{x}}$.

854. $y = x\sqrt{1+x^2}$.

855. $y = (1+x)\sqrt{2+x^2}\sqrt[3]{3+x^3}$.

856. $y = \sqrt[m+n]{(1-x)^m(1+x)^n}$.

857. $y = \frac{x}{\sqrt{a^2-x^2}}$.

858. $y = \sqrt[3]{\frac{1+x^3}{1-x^3}}$.

859. $y = \frac{1}{\sqrt{1+x^2}(x+\sqrt{1+x^2})}$.

860. $y = \sqrt{x+\sqrt{x+\sqrt{x}}}$.

861. $y = \sqrt[3]{1 + \sqrt[3]{1 + \sqrt[3]{x}}}$.
863. $y = (2 - x^2) \cos x + 2x \sin x$.
865. $y = \sin^n x \cos nx$.
867. $y = \frac{\sin^2 x}{\sin x^2}$.
869. $y = \frac{1}{\cos^n x}$.
871. $y = \operatorname{tg} \frac{x}{2} - \operatorname{ctg} \frac{x}{2}$.
873. $y = 4\sqrt[3]{\operatorname{ctg}^2 x} + \sqrt[3]{\operatorname{ctg}^8 x}$.
875. $y = \sin \left[\cos^2 (\operatorname{tg}^3 x) \right]$.
877. $y = 2^{\operatorname{tg}^{1/x}}$.
879. $y = \left[\frac{1-x^2}{2} \sin x - \frac{(1-x)^2}{2} \cos x \right] e^{-x}$.
881. $y = \frac{\ln 3 \cdot \sin x + \cos x}{3^x}$.
883. $y = e^x + e^{e^x} + e^{e^{e^x}}$.
885. $y = x^{a^a} + a^{x^a} + a^{a^x} \quad (a > 0)$.
887. $y = \ln(\ln(\ln x))$.
889. $y = \frac{1}{2} \ln(1+x) - \frac{1}{4} \ln(1+x^2) - \frac{1}{2(1+x)}$.
891. $y = \frac{1}{4(1+x^4)} + \frac{1}{4} \ln \frac{x^4}{1+x^4}$.
893. $y = \frac{1}{1-k} \ln \frac{1+x}{1-x} + \frac{\sqrt{k}}{1-k} \ln \frac{1+x\sqrt{k}}{1-x\sqrt{k}} \quad (0 < k < 1)$.
894. $y = \sqrt{x+1} - \ln(1 + \sqrt{x+1})$.
896. $y = x \ln(x + \sqrt{1+x^2}) - \sqrt{1+x^2}$.
897. $y = x \ln^2(x + \sqrt{1+x^2}) - 2\sqrt{1+x^2} \ln(x + \sqrt{1+x^2}) + 2x$.
898. $y = \frac{x}{2} \sqrt{x^2 + a^2} + \frac{a^2}{2} \ln(x + \sqrt{x^2 + a^2})$.
899. $y = \frac{1}{2\sqrt{ab}} \ln \frac{\sqrt{a} + x\sqrt{b}}{\sqrt{a} - x\sqrt{b}} \quad (a > 0, b > 0)$.
862. $y = \cos 2x - 2 \sin x$.
864. $y = \sin(\cos^2 x) \cdot \cos(\sin^2 x)$.
866. $y = \sin[\sin(\sin x)]$.
868. $y = \frac{\cos x}{2 \sin^2 x}$.
870. $y = \frac{\sin x - x \cos x}{\cos x + x \sin x}$.
872. $y = \operatorname{tg} x - \frac{1}{3} \operatorname{tg}^3 x + \frac{1}{5} \operatorname{tg}^5 x$.
874. $y = \sec^2 \frac{x}{a} + \operatorname{cosec}^2 \frac{x}{a}$.
876. $y = e^{-x^2}$.
878. $y = e^x (x^2 - 2x + 2)$.
880. $y = e^x \left(1 + \operatorname{ctg} \frac{x}{2} \right)$.
882. $y = e^{ax} \frac{a \sin bx - b \cos bx}{\sqrt{a^2 + b^2}}$.
884. $y = \left(\frac{a}{b} \right)^x \left(\frac{b}{x} \right)^a \left(\frac{x}{a} \right)^b \quad (a > 0, b > 0)$.
886. $y = \operatorname{tg}^3 x^2$.
888. $y = \ln(\ln^2(\ln^3 x))$.
890. $y = \frac{1}{4} \ln \frac{x^2 - 1}{x^2 + 1}$.
892. $y = \frac{1}{2\sqrt{6}} \ln \frac{x\sqrt{3} - \sqrt{2}}{x\sqrt{3} + \sqrt{2}}$.
895. $y = \ln(x + \sqrt{x^2 + 1})$.

$$900. y = \frac{2+3x^2}{x^4} \sqrt{1-x^2} + 3 \ln \frac{1+\sqrt{1-x^2}}{x}.$$

$$901. y = \ln \operatorname{tg} \frac{x}{2}.$$

$$902. y = \ln \operatorname{tg} \left(\frac{x}{2} + \frac{p}{4} \right).$$

$$903. y = \frac{1}{2} \operatorname{ctg}^2 x + \ln \sin x.$$

$$904. y = \ln \sqrt{\frac{1-\sin x}{1+\sin x}}.$$

$$905. y = -\frac{\cos x}{2 \sin^2 x} + \ln \sqrt{\frac{1+\cos x}{\sin x}}.$$

$$906. y = \ln \frac{b+a \cos x + \sqrt{b^2-a^2} \sin x}{a+b \cos x} \quad (0 \leq |a| < |b|).$$

$$907. y = \frac{1}{x} (\ln^3 x + 3 \ln^2 x + 6 \ln x + 6).$$

$$908. y = \frac{1}{4x^4} \ln \frac{1}{x} - \frac{1}{16x^4}.$$

$$909. y = \frac{3}{2} (1 - \sqrt[3]{1+x^2}) + 3 \ln (1 + \sqrt[3]{1+x^2}).$$

$$910. y = \ln \left[\frac{1}{x} + \ln \left(\frac{1}{x} + \ln \frac{1}{x} \right) \right].$$

$$911. y = x [\sin(\ln x) - \cos(\ln x)].$$

$$912. y = \ln \operatorname{tg} \frac{x}{2} - \cos x \cdot \ln \operatorname{tg} x.$$

$$913. y = \arcsin \frac{x}{2}.$$

$$914. y = \arccos \frac{1-x}{\sqrt{2}}.$$

$$915. y = \operatorname{arctg} \frac{x^2}{a}.$$

$$916. y = \frac{1}{\sqrt{2}} \operatorname{arctg} \frac{\sqrt{2}}{x}.$$

$$917. y = \sqrt{x} - \operatorname{arctg} \sqrt{x}.$$

$$918. y = x + \sqrt{1-x^2} \cdot \arccos x.$$

$$919. y = x \arcsin \sqrt{\frac{x}{1+x}} + \operatorname{arctg} \sqrt{x} - \sqrt{x}.$$

$$920. y = \arccos \frac{1}{x}.$$

$$921. y = \arcsin(\sin x).$$

$$922. y = \arccos(\cos^2 x).$$

$$923. y = \arcsin(\sin x - \cos x).$$

$$924. y = \arccos \sqrt{1-x^2}.$$

$$925. y = \operatorname{arctg} \frac{1+x}{1-x}.$$

$$926. y = \operatorname{arctg} \left(\frac{\sin x + \cos x}{\sin x - \cos x} \right).$$

$$927. y = \frac{2}{\sqrt{a^2-b^2}} \operatorname{arctg} \left(\sqrt{\frac{a-b}{a+b}} \operatorname{tg} \frac{x}{2} \right) \quad (a > b \geq 0).$$

$$928. y = \arcsin \frac{1-x^2}{1+x^2}.$$

$$929. y = \frac{1}{\arccos^2(x^2)}.$$

$$930. y = \operatorname{arctg} x + \frac{1}{3} \operatorname{arctg}(x^3).$$

$$931. y = \ln(1 + \sin^2 x) - 2 \sin x \cdot \operatorname{arctg}(\sin x).$$

$$932. y = \ln \left(\arccos \frac{1}{\sqrt{x}} \right).$$

$$933. y = \ln \frac{x+a}{\sqrt{x^2+b^2}} + \frac{a}{b} \operatorname{arctg} \frac{x}{b} \quad (b \neq 0).$$

$$934. y = \frac{x}{2} \sqrt{a^2-x^2} + \frac{a^2}{2} \arcsin \frac{x}{a} \quad (a > 0).$$

$$935. y = \frac{1}{6} \ln \frac{(x+1)^2}{x^2-x+1} + \frac{1}{\sqrt{3}} \operatorname{arctg} \frac{2x-1}{\sqrt{3}}.$$

$$936. y = \frac{1}{4\sqrt{2}} \ln \frac{x^2+x\sqrt{2}+1}{x^2-x\sqrt{2}+1} - \frac{1}{2\sqrt{2}} \operatorname{arctg} \frac{x\sqrt{2}}{x^2-1}.$$

$$937. y = x(\arcsin x)^2 + 2\sqrt{1-x^2} \arcsin x - 2x.$$

$$938. y = \frac{\arccos x}{x} + \frac{1}{2} \ln \frac{1-\sqrt{1-x^2}}{1+\sqrt{1-x^2}}.$$

$$939. y = \operatorname{arctg} \sqrt{x^2-1} - \frac{\ln x}{\sqrt{x^2-1}}.$$

$$940. y = \frac{\arcsin x}{\sqrt{1-x^2}} + \frac{1}{2} \ln \frac{1-x}{1+x}.$$

$$941. y = \frac{1}{12} \ln \frac{x^4-x^2+1}{(x^2+1)^2} - \frac{1}{2\sqrt{3}} \operatorname{arctg} \frac{\sqrt{3}}{2x^2-1}.$$

$$942. y = \frac{x^6}{1+x^{12}} - \operatorname{arccctg} x^6.$$

$$943. y = \ln \frac{1-\sqrt[3]{x}}{\sqrt{1+\sqrt[3]{x}+\sqrt[3]{x^2}}} + \sqrt{3} \operatorname{arctg} \frac{1+2\sqrt[3]{x}}{\sqrt{3}}.$$

$$944. y = \operatorname{arctg} \frac{x}{1+\sqrt{1-x^2}}.$$

$$945. y = \operatorname{arccctg} \frac{a-2x}{2\sqrt{ax-x^2}} \quad (a > 0).$$

$$946. y = \frac{3-x}{2} \sqrt{1-2x-x^2} + 2 \arcsin \frac{1+x}{\sqrt{2}}.$$

$$947. y = \frac{1}{4} \ln \frac{\sqrt[4]{1+x^4}+x}{\sqrt[4]{1+x^4}-x} - \frac{1}{2} \operatorname{arctg} \frac{\sqrt[4]{1+x^4}}{x}.$$

$$948. y = \operatorname{arctg} (\operatorname{tg}^2 x).$$

$$949. y = \sqrt{1-x^2} \cdot \ln \sqrt{\frac{1-x}{1+x}} + \frac{1}{2} \ln \frac{1-\sqrt{1-x^2}}{1+\sqrt{1-x^2}} + \sqrt{1-x^2} + \arcsin x.$$

$$950. y = x \operatorname{arctg} x - \frac{1}{2} \ln(1+x^2) - \frac{1}{2} (\operatorname{arctg} x)^2.$$

$$951. y = \ln(e^x + \sqrt{1+e^{2x}}).$$

$$952. y = \operatorname{arctg} (x + \sqrt{1+x^2}).$$

$$953. y = \arcsin \left(\frac{\sin a \sin x}{1 - \cos a \cos x} \right).$$

$$954. y = \frac{1}{4\sqrt{3}} \ln \frac{\sqrt{x^2+2}-x\sqrt{3}}{\sqrt{x^2+2}+x\sqrt{3}} + \frac{1}{2} \operatorname{arctg} \frac{\sqrt{x^2+2}}{x}.$$

$$955. y = \frac{1}{2\sqrt{2}} \operatorname{arctg} \frac{x\sqrt{2}}{\sqrt{1+x^4}} - \frac{1}{4\sqrt{2}} \ln \frac{\sqrt{1+x^4}-x\sqrt{2}}{\sqrt{1+x^4}+x\sqrt{2}}.$$

$$956. y = \frac{x\sqrt{1-x^2}}{1+x^2} - \frac{3}{\sqrt{2}} \operatorname{arccctg} \frac{x\sqrt{2}}{\sqrt{1-x^2}}.$$

$$957. y = \arccos(\sin x^2 - \cos x^2).$$

$$958. y = \arcsin(\sin x^2) + \arccos(\cos x^2).$$

$$959. y = e^{m \arcsin x} [\cos(m \arcsin x) + \sin(m \arcsin x)].$$

$$960. y = \operatorname{arctg} e^x - \ln \sqrt{\frac{e^{2x}}{e^{2x}+1}}.$$

$$960.1. y = \sqrt{1+\sqrt[3]{1+\sqrt[4]{1+x^4}}}$$

$$960.2. y = \operatorname{arccctg} \frac{1}{\sqrt{\operatorname{ctg} \frac{1}{x^2}}}.$$

$$960.3. y = \ln^2(\sec 2^{\sqrt[3]{x}}).$$

$$961. y = x + x^x + x^{x^x} \quad (x > 0).$$

$$962. y = x^{x^a} + x^{a^x} + a^{x^x} \quad (a > 0, x > 0).$$

$$963. y = \sqrt[x]{x} \quad (x > 0).$$

$$964. y = (\sin x)^{\cos x} + (\cos x)^{\sin x}.$$

$$965. y = (\ln x)^x : x^{\ln x}.$$

$$965.1. y = \left[\frac{\arcsin(\sin^2 x)}{\arccos(\cos^2 x)} \right]^{\operatorname{arctg}^2 x}.$$

$$966. y = \log_x e.$$

$$967. y = \ln(chx) + \frac{1}{2ch^2x}.$$

$$968. y = \frac{chx}{sh^2x} - \ln\left(\frac{cth\frac{x}{2}}{2}\right).$$

$$969. y = \operatorname{arctg}(tgx).$$

$$970. y = \arccos\left(\frac{1}{chx}\right).$$

$$971. y = \frac{b}{a}x + \frac{2\sqrt{a^2 - b^2}}{a} \operatorname{arctg}\left(\sqrt{\frac{a-b}{a+b}} th\frac{x}{2}\right) \quad (0 \leq |b| < a).$$

972. $u = \cos^2 x$ o'zgaruvchi kiritib, ushbu

$$y = \ln(\cos^2 x + \sqrt{1 + \cos^4 x})$$

funksiyaning hosilasini toping.

Avvalgi misolda ko'rsatilgan usulni qo'llab, quyidagi funksiyalarning hosilasini toping (973-976):

$$973. y = (\arccos x)^2 \left[\ln^2(\arccos x) - \ln(\arccos x) + \frac{1}{2} \right].$$

$$974. y = \frac{1}{2} \operatorname{arctg}\left(\sqrt[4]{1+x^4}\right) + \frac{1}{4} \ln \frac{\sqrt[4]{1+x^4} + 1}{\sqrt[4]{1+x^4} - 1}.$$

$$975. y = \frac{e^{-x^2} \arcsin(e^{-x^2})}{\sqrt{1-e^{-2x^2}}} + \frac{1}{2} \ln(1-e^{-2x^2}).$$

$$976. y = \frac{a^x}{1+a^{2x}} - \frac{1-a^{2x}}{1+a^{2x}} \operatorname{arccotg} a^{-x}.$$

977. Quyidagi funksiyalarning hosilasini toping, ularning va hosilalarining grafiklarini yasang:

$$a) y = |x|; \quad b) y = x|x|; \quad v) y = \ln|x|.$$

978. Quyidagi funksiyalarning hosilasini toping:

$$a) y = [(x-1)^2(x+1)^3]; \quad b) y = |\sin^3 x|;$$

$$v) y = \arccos \frac{1}{|x|}; \quad g) y = [x] \sin^2 px.$$

Quyidagi funksiyalarning hosilasini toping, ularning va hosilalarining grafiklarini yasang (979-983):

$$979. y = \begin{cases} 1-x, & -\infty < x < 1; \\ (1-x)(2-x), & 1 \leq x \leq 2; \\ -(2-x), & 2 < x < +\infty. \end{cases}$$

$$980. y = \begin{cases} (x-a)^2(x-b)^2, & a \leq x \leq b; \\ 0, & x \notin [a, b]. \end{cases}$$

$$981. y = \begin{cases} x, & x < 0; \\ \ln(1+x), & x \geq 0. \end{cases}$$

$$982. y = \begin{cases} \operatorname{arctg} x, & |x| \leq 1; \\ \frac{p}{4} \operatorname{sgn} x + \frac{x-1}{2}, & |x| > 1. \end{cases}$$

$$983. y = \begin{cases} x^2 e^{-x^2}, & |x| \leq 1; \\ \frac{1}{e}, & |x| > 1. \end{cases}$$

984. Berilgan $y = f(x)$ funksiya logarifmining hosilasi shu funksiyaning logarifmik hosilasi deyiladi:

$$\frac{y'}{y} = \frac{d}{dx} \ln |f(x)| \equiv \frac{f'(x)}{f(x)}.$$

Quyidagi funksiyalarning logarifmik hosilasini toping:

$$\begin{aligned} \text{a) } y &= x \sqrt{\frac{1-x}{1+x}}; & \text{b) } y &= \frac{x^2}{1-x} \sqrt[3]{\frac{3-x}{(3+x)^2}}; \\ \text{v) } y &= (x-a_1)^{a_1} (x-a_2)^{a_2} \dots (x-a_n)^{a_n}; & \text{g) } y &= (x + \sqrt{1+x^2})^n. \end{aligned}$$

985. $j(x)$ va $y(x)$ funksiyalar x o'zgaruvchi bo'yicha differensiallanuvchi funksiyalar bo'lsin. Quyidagi funksiyalarning hosilasini toping:

$$\begin{aligned} \text{a) } y &= \sqrt{j^2(x) + y^2(x)}; & \text{b) } y &= \operatorname{arctg} \frac{j(x)}{y(x)}; \\ \text{v) } y &= j^{(x)} \sqrt[y(x)]{} \quad (j(x) \neq 0; y(x) > 0); \\ \text{g) } y &= \log_{j(x)} y(x) \quad (j(x) > 0; y(x) > 0). \end{aligned}$$

986. Agar $f(u)$ differensiallanuvchi bo'lsa, y' ni toping:

$$\begin{aligned} \text{a) } y &= f(x^2); & \text{b) } y &= f(\sin^2 x) + f(\cos^2 x); \\ \text{v) } y &= f(e^x) \cdot e^{f(x)}; & \text{g) } y &= f\{f[f(x)]\}. \end{aligned}$$

986.1. Ushbu

$$f(x) = x(x-1)(x-2) \dots (x-1000)$$

funksiya uchun $f'(0)$ ni toping.

987. Quyidagi n - tartibli determinantni differensiallash qoidasini isbotlang:

$$\begin{vmatrix} f_{11}(x) & f_{12}(x) & \dots & f_{1n}(x) \\ \dots & \dots & \dots & \dots \\ f_{k1}(x) & f_{k2}(x) & \dots & f_{kn}(x) \\ \dots & \dots & \dots & \dots \\ f_{n1}(x) & f_{n2}(x) & \dots & f_{nn}(x) \end{vmatrix} = \sum_{k=1}^n \begin{vmatrix} f_{11}(x) & f_{12}(x) & \dots & f_{1n}(x) \\ \dots & \dots & \dots & \dots \\ f'_{k1}(x) & f'_{k2}(x) & \dots & f'_{kn}(x) \\ \dots & \dots & \dots & \dots \\ f_{n1}(x) & f_{n2}(x) & \dots & f_{nn}(x) \end{vmatrix}.$$

988. $F'(x)$ ni toping:

$$F(x) = \begin{vmatrix} x-1 & 1 & 2 \\ -3 & x & 3 \\ -2 & -3 & x+1 \end{vmatrix}.$$

989. $F'(x)$ ni toping:

$$F(x) = \begin{vmatrix} x & x^2 & x^3 \\ 1 & 2x & 3x^2 \\ 0 & 2 & 6x \end{vmatrix}.$$

990. Funksiya grafigi berilgan. Uning hosilasining grafigini taqribiy yasang.

991. Ushbu

$$f(x) = \begin{cases} x^2 \sin \frac{1}{x}, & x \neq 0; \\ 0, & x = 0. \end{cases}$$

funksiya uzilishga ega bo'lgan hosilaga ega ekanligini isbotlang.

992. Qanday shartlar bajarilganda

$$f(x) = x^n \sin \frac{1}{x} \quad (x \neq 0) \quad \text{va} \quad f(0) = 0$$

funksiya a) $x = 0$ nuqtada uzluksiz; b) $x = 0$ nuqtada differensiallanuvchi; v) $x = 0$ nuqtada uzluksiz hosilaga ega?

993. Qanday shartlar bajarilganda

$$f(x) = |x|^m \sin \frac{1}{|x|^m} \quad (x \neq 0) \quad \text{va} \quad f(0) = 0 \quad (m > 0)$$

funksiya a) koordinata boshi atrofida chegaralagan hosilaga ega; b) shu atrofda chegaralan-magan hosilaga ega?

994. Agar

$$f(x) = (x - a)j(x)$$

bo`lsa, $f'(a)$ ni toping, bunda $j(x)$ funksiya $x = a$ nuqtada uzluksiz.

995. Ushbu

$$f(x) = |x - a|j(x)$$

funksiya a nuqtada hosilaga ega emasligini ko`rsating, bunda $j(x)$ funksiya uzluksiz va $j(a) \neq 0$.

Bir tomonlama $f'_-(a)$ va $f'_+(a)$ hosilalar nimaga teng?

996. Berilgan a_1, a_2, \dots, a_n nuqtalarda hosilaga ega bo`lmagan uzluksiz funksiyaga misol quring.

997. Ushbu

$$f(x) = x^2 \left| \cos \frac{p}{x} \right| \quad (x \neq 0) \quad \text{va} \quad f(0) = 0$$

funksiya $x = 0$ nuqtaning ixtiyoriy atrofida hosilaga ega bo`lmaydigan nuqtalarga ega, lekin $x = 0$ nuqtaning o`zida hosilaga ega ekanligini isbotlang.

Bu funksiya grafigining eskizini yasang.

998. Ushbu

$$f(x) = \begin{cases} x^2, & \text{agar } x \text{ raional b\u00fclsa;} \\ 0, & \text{agar } x \text{ irraional b\u00fclsa} \end{cases}$$

funksiya faqat $x = 0$ nuqtada hosilaga ega ekanligini isbotlang.

999. Quyidagi funksiyalarni differensiallanuvchilikka tekshiring:

$$\text{a) } y = \left| (x-1)(x-2)^2(x-3)^3 \right|; \quad \text{b) } y = |\cos x|; \quad \text{v) } y = |p^2 - x^2| \sin^2 x;$$

$$\text{g) } y = \arcsin(\cos x); \quad \text{d) } y = \begin{cases} \frac{x-1}{4}(x+1)^2, & |x| \leq 1; \\ |x| - 1, & |x| > 1. \end{cases}$$

Quyidagi $f(x)$ funksiya uchun chap $f'_-(x)$ va o`ng $f'_+(x)$ hosilalarni toping (1000-1008):

$$1000. f(x) = |x|.$$

$$1001. f(x) = [x] \sin px.$$

$$1002. f(x) = x \left| \cos \frac{p}{x} \right| \quad (x \neq 0), \quad f(0) = 0.$$

$$1003. f(x) = \sqrt{\sin x^2}.$$

$$1004. f(x) = \frac{x}{1 + e^{1/x}} \quad (x \neq 0), \quad f(0) = 0.$$

$$1005. f(x) = \sqrt{1 - e^{-x^2}}.$$

$$1006. f(x) = |\ln|x|| \quad (x \neq 0).$$

$$1007. f(x) = \arcsin \frac{2x}{1+x^2}.$$

$$1008. f(x) = (x-2) \operatorname{arctg} \frac{1}{x-2} \quad (x \neq 2), \quad f(2) = 0.$$

1009. Ushbu

$$f(x) = x \sin \frac{1}{x} \quad x \neq 0 \quad \text{va} \quad f(0) = 0$$

funksiya $x=0$ nuqtada uzluksiz, lekin bu nuqtada chap va o'ng hosilalarga ega emasligini isbotlang.

1009.1. x_0 nuqta $f(x)$ funksiyaning 1-tur uzilish nuqtasi bo'lsin. U holda

$$f'_-(x_0) = \lim_{h \rightarrow -0} \frac{f(x_0+h) - f(x_0-0)}{h} \quad \text{va} \quad f'_+(x_0) = \lim_{h \rightarrow +0} \frac{f(x_0+h) - f(x_0+0)}{h}$$

ifodalar $f(x)$ funksiyaning x_0 nuqtadagi umumlashgan bir tomonlama (mos ravishda chap va o'ng) hosilalari deyiladi.

Quyidagi funksiyalarning x_0 uzilish nuqtasidagi $f'_-(x_0)$ va $f'_+(x_0)$ hosilalarini toping:

$$\text{a) } f(x) = \sqrt{\frac{x^2 + x^3}{x}}; \quad \text{b) } f(x) = \operatorname{arctg} \frac{1+x}{1-x}; \quad \text{v) } f(x) = \frac{1}{1+e^{1/x}}.$$

1010. Ushbu

$$f(x) = \begin{cases} x^2, & x \leq x_0; \\ ax+b, & x > x_0 \end{cases}$$

funksiya $x = x_0$ nuqtada uzluksiz va hosilaga ega bo'lishi uchun a va b koeffitsientlarni qanday tanlash kerak?

1011. $x = x_0$ nuqtada chapdan differensiallanuvchi bo'lgan ushbu

$$F(x) = \begin{cases} f(x), & x \leq x_0; \\ ax+b, & x > x_0 \end{cases}$$

funksiya $x = x_0$ nuqtada uzluksiz va hosilaga ega bo'lishi uchun a va b koeffitsientlarni qanday tanlash kerak?

1012. $a \leq x \leq b$ kesmada $y = A(x-a)(x-b)(x-c)$ kubik parabola yordamida (bunda A va c parametrlarni aniqlanadi) ushbu

$$y = k_1(x-a) \quad (-\infty < x < a), \quad y = k_2(x-b) \quad (b < x < +\infty)$$

ikkita yarim to'g'ri chiziqlarni ulang.

$$1013. y = \frac{m^2}{|x|} \quad (|x| > c) \quad \text{egri chiziq qismini} \quad y = a + bx^2 \quad (|x| \leq c) \quad (a \text{ va } b - \text{noma'lum}$$

parametrlar) parabola bilan shunday to'ldiringki, natijada silliq chiziq hosil bo'lsin.

1014. Agar: a) $f(x)$ funksiya x_0 nuqtada hosilaga ega, $g(x)$ funksiya bu nuqtada hosilaga ega bo'lmasa; b) $f(x)$ va $g(x)$ funksiyalar x_0 nuqtada hosilaga ega bo'lmasa, $F(x) = f(x) + g(x)$ funksiya $x = x_0$ nuqtada hosilaga ega emas deb tasdiqlash mumkinmi?

1015. Agar: a) $f(x)$ funksiya x_0 nuqtada hosilaga ega, $g(x)$ funksiya bu nuqtada hosilaga ega bo'lmasa; b) $f(x)$ va $g(x)$ funksiyalar x_0 nuqtada hosilaga ega bo'lmasa, $F(x) = f(x)g(x)$ funksiya $x = x_0$ nuqtada hosilaga ega emas deb tasdiqlash mumkinmi? $x_0 = 0$ uchun quyidagi misollarni ko'ring:

$$\text{a) } f(x) = x, \quad g(x) = |x|; \quad \text{b) } f(x) = |x|, \quad g(x) = |x|.$$

1016. Agar: a) $f(x)$ funksiya $x = g(x_0)$ nuqtada hosilaga ega, $g(x)$ funksiya $x = x_0$ nuqtada hosilaga ega bo'lmasa; b) $f(x)$ funksiya $x = g(x_0)$ nuqtada hosilaga ega emas, $g(x)$ funksiya esa $x = x_0$ nuqtada hosilaga ega bo'lsa; v) $f(x)$ funksiya $x = g(x_0)$ nuqtada hosilaga ega emas, $g(x)$ funksiya esa $x = x_0$ nuqtada hosilaga ega emas bo'lsa, $F(x) = f(g(x))$ funksiyaning $x = x_0$ nuqtada differentsiallanuvchiligi haqida nima deyish mumkin?

$x_0 = 0$ uchun misollar ko'ring:

a) $f(x) = x^2$, $g(x) = |x|$; b) $f(x) = |x|$, $g(x) = x^2$;

v) $f(x) = 2x + |x|$, $g(x) = \frac{2}{3}x - \frac{1}{3}|x|$.

1017. $y = x + \sqrt[3]{\sin x}$ funksiyaning grafigi qanday nuqtalarda vertikal urinmalarga ega? Bu grafikni yasang.

1018. $f(x)$ funksiya o'zining uzilish nuqtasida a) chekli hosilaga; b) cheksiz hosilaga ega bo'lishi mumkinmi?

Misol sifatida $f(x) = \operatorname{sgn} x$ funksiyaning ko'ring.

1019. Agar $f(x)$ funksiya chegaralangan (a, b) intervalda differentsiallanuvchi va $\lim_{x \rightarrow a} f(x) = \infty$ bo'lsa, u holda ushbu

1) $\lim_{x \rightarrow a} f'(x) = \infty$; 2) $\lim_{x \rightarrow a} |f'(x)| = +\infty$

tengliklar albatta bajarilishi shartmi?

Misol sifatida $x \rightarrow 0$ da $f(x) = \frac{1}{x} + \cos \frac{1}{x}$ funksiyaning ko'ring.

1020. Agar $f(x)$ funksiya chegaralangan (a, b) intervalda differentsiallanuvchi va $\lim_{x \rightarrow a} f'(x) = \infty$ bo'lsa, u holda ushbu

$$\lim_{x \rightarrow a} f(x) = \infty$$

tenglik albatta bajarilishi shartmi?

Misol sifatida $x \rightarrow 0$ da $f(x) = \sqrt[3]{x}$ funksiyaning ko'ring.

1021. $f(x)$ funksiya $(x_0, +\infty)$ intervalda differentsiallanuvchi va $\lim_{x \rightarrow +\infty} f(x)$ mavjud bo'lsin. Bundan $\lim_{x \rightarrow +\infty} f'(x)$ limitning mavjudligi kelib chiqadimi?

Misol sifatida $f(x) = \frac{\sin(x^2)}{x}$ funksiyaning ko'ring.

1022. Chegaralangan $f(x)$ funksiya $(x_0, +\infty)$ intervalda differentsiallanuvchi va $\lim_{x \rightarrow \infty} f'(x)$ mavjud bo'lsin. Bundan chekli yoki cheksiz $\lim_{x \rightarrow \infty} f(x)$ limitning mavjudligi kelib chiqadimi?

Misol sifatida $f(x) = \cos(\ln x)$ funksiyaning ko'ring.

1023. Funksiyalar orasidagi tengsizlikni hadma-had differentsiallashtirish mumkinmi?

1024. Yig'indilarni hisoblash formulalarini keltirib chiqaring:

$$P_n = 1 + 2x + 3x^2 + \dots + nx^{n-1}$$

va

$$Q_n = 1^2 + 2^2 x + 3^2 x^2 + \dots + n^2 x^{n-1}.$$

Yo'llanma. $(x + x^2 + \dots + x^n)'$ ni ko'ring.

1025. Yig`indilarni hisoblash formulalarini keltirib chiqaring:

$$S_n = \sin x + \sin 2x + \dots + \sin nx$$

va

$$T_n = \cos x + 2\cos 2x + \dots + n\cos nx.$$

1025.1. Yig`indini hisoblash formulasini keltirib chiqaring:

$$S_n = \operatorname{ch} x + 2\operatorname{ch} 2x + \dots + n \operatorname{ch} nx.$$

Y o`l l a n m a. $S_n = (\operatorname{sh} x + \operatorname{sh} 2x + \dots + \operatorname{sh} nx)'$.

1026. Ushbu

$$\cos \frac{x}{2} \cos \frac{x}{4} \dots \cos \frac{x}{2^n} = \frac{\sin x}{2^n \sin \frac{x}{2^n}}$$

ayniyatdan foydalanib, yig`indini hisoblash formulasini keltirib chiqaring:

$$S_n = \frac{1}{2} \operatorname{tg} \frac{x}{2} + \frac{1}{4} \operatorname{tg} \frac{x}{4} + \dots + \frac{1}{2^n} \operatorname{tg} \frac{x}{2^n}.$$

1027. Differensiallanuvchi juft funksiyaning hosilasi toq, differensiallanuvchi toq funksiyaning hosilasi esa juft funksiya ekanligini isbotlang.

Bu tasdiqni geometrik nuqtai-nazardan izoxlang.

1028. Davri T bo`lgan differensiallanuvchi davriy funksiyaning hosilasi yana T davrli davriy funksiya ekanligini isbotlang.

1029. Doiraning radiusi $R = 10$ sm bo`lib, u 2 sm/s tezlik bilan tekis o`ssa, u holda o`sha vaqtda doiraning yuzi qanday tezlik bilan o`sadi?

1030. To`g`ri to`rtburchakning tomonlari $x = 20$ m va $y = 15$ m bo`lib, birinchi tomoni 1 m/s tezlik bilan kamaysa, ikkinchi tomoni esa 2 m/s tezlik bilan o`ssa, u holda o`sha vaqtda to`g`ri to`rtburchakning yuzi va diametri qanday tezlik bilan o`zgaradi?

1031. Bitta portdan bir vaqtning o`zida shimol yo`nalishida A paraxod va sharq yo`nalishida B paraxod yo`lga chiqdi. Agar A paraxodning tezligi 30 km/s, B paraxodniki esa 40 km/c bo`lsa, ular orasidagi masofa qanday tezlik bilan o`sadi?

1032. $S(x)$ funksiya ushbu

$$f(x) = \begin{cases} x, & 0 \leq x \leq 2; \\ 2x - 2, & 2 < x < +\infty \end{cases}$$

egri chiziq, Ox o`qi va Ox o`qiga x ($x \geq 0$) nuqtada o`tkazilgan perpendikulyar orasidagi yuzani ifodalovchi funksiya bo`lsin. $S(x)$ funksiyaning analitik ko`rinishini tuzing, uning $S'(x)$ hosilasini toping va $y = S'(x)$ funksiyaning grafigini yasang.

1033. $S(x)$ funksiya ushbu

$$y = \sqrt{a^2 - x^2}$$

aylana yoyi, Ox o`qi va Ox o`qiga 0 va x ($|x| \leq a$) nuqtalarda o`tkazilgan ikki perpendikulyarlar orasidagi yuzani ifodalovchi funksiya bo`lsin. $S(x)$ funksiyaning analitik ko`rinishini tuzing, uning $S'(x)$ hosilasini toping va $y = S'(x)$ funksiyaning grafigini yasang.

2. Teskari funksiya hosilasi. Parametrik funksiya hosilasi.

Oshkormas funksiya hosilasi

1034. $y^3 + 3y = x$ tenglama bilan aniqlanadigan bir qiymatli $y = y(x)$ funksiya mavjud ekanligini isbotlang va uning y'_x hosilasini toping.

1035. $y - e \sin y = x$ ($0 \leq e < 1$) tenglama bilan aniqlanadigan bir qiymatli $y = y(x)$ funksiya mavjud ekanligini isbotlang va uning y'_x hosilasini toping.

1036. Quyidagi funksiyalar uchun $x = x(y)$ teskari funksiyaning aniqlanish sohasini toping va ularning hosilasini toping:

a) $y = x + \ln x$ ($x > 0$); b) $y = x + e^x$; v) $y = sh x$; g) $y = th x$.

1037. Quyidagi funksiyalar uchun $x = x(y)$ teskari funksiyaning bir qiymatli uzluksiz yaproqlarini ajrating, ularning hosilalarini toping va grafiklarini yasang:

a) $y = 2x^2 - x^4$; b) $y = \frac{x^2}{1+x^2}$; v) $y = 2e^{-x} - e^{-2x}$.

1038. Agar $x = -1 + 2t - t^2$, $y = 2 - 3t + t^3$ bo'lsa, $y = y(x)$ funksiya grafigi eskizini chizing va y'_x hosilasini toping. $x = 0$ va $x = -1$ da y'_x hosilaning qiymati nimaga teng? Qanday $M(x, y)$ nuqtada $y'_x(x) = 0$?

Quyidagi parametrik ko'rinishda berilgan funksiyalar uchun y'_x hosilalarni toping (parametrlar musbat, 1039-1046):

1039. $x = \sqrt[3]{1 - \sqrt{t}}$, $y = \sqrt{1 - \sqrt[3]{t}}$.

1040. $x = \sin^2 t$, $y = \cos^2 t$.

1041. $x = a \cos t$, $y = b \sin t$.

1042. $x = a ch t$, $y = b sh t$.

1043. $x = a \cos^3 t$, $y = a \sin^3 t$.

1044. $x = a(t - \sin t)$, $y = a(1 - \cos t)$.

1045. $x = e^{2t} \cos^2 t$, $y = e^{2t} \sin^2 t$.

1046. $x = \arcsin \frac{t}{\sqrt{1+t^2}}$, $y = \arccos \frac{1}{\sqrt{1+t^2}}$.

1047. Ushbu

$$x = 2t + |t|, \quad y = 5t^2 + 4t|t|$$

tenglamalar sistemasi bilan aniqlanadigan $y = y(x)$ funksiya $t = 0$ nuqtada differentsiallanuvchi, lekin bu nuqtada uning hosilasini odatdagi formula bilan topib bo'lmashligini isbotlang.

Quyidagi oshkormas funksiyalarning y'_x hosilalarini toping (1048-1053):

1048. $x^2 + 2xy - y^2 = 2x$.

$x = 2$, $y = 4$ va $x = 2$, $y = 0$ nuqtalardagi y' hosila nimaga teng?

1049. $y^2 = 2px$ (parabola).

1050. $\frac{x^2}{a^2} + \frac{y^2}{b^2} = 1$ (ellips).

1051. $\sqrt{x} + \sqrt{y} = \sqrt{a}$ (parabola).

1052. $x^{2/3} + y^{2/3} = a^{2/3}$ (astroida).

1053. $\operatorname{arctg} \frac{y}{x} = \ln \sqrt{x^2 + y^2}$ (logarifmik spiral').

1054. Agar

a) $r = aj$ (Arximed spirali); b) $r = a(1 + \cos j)$ (kardioida);

v) $r = ae^{mj}$ (logarifmik spiral'), bunda $r = \sqrt{x^2 + y^2}$ va $j = \operatorname{arctg} \frac{y}{x}$ - qutb koordinatlar.

3. Hosilaning geometrik ma'nosi

1055. $y = (x+1)\sqrt[3]{3-x}$ egri chiziqqa a) $A(-1, 0)$; b) $(2, 3)$; v) $C(3, 0)$ nuqtalarda o'tkazilgan urinma va normalning tenglamalarini tuzing.

1056. Qanday nuqtalarda $y = 2 + x - x^2$ egri chiziqqa o'tkazilgan urinma a) Ox o'qiga parallel; b) birinchi chorak bissektrisasiga parallel bo'ladi?

1057. Ushbu

$$y = a(x - x_1)(x - x_2) \quad (a \neq 0, x_1 < x_2)$$

parabola Ox o'qini bir-biriga teng bo'lgan a va b $\left(0 < a < \frac{p}{2}, 0 < b < \frac{p}{2}\right)$ burchaklar ostida kesib o'tishini isbotlang.

1058. $y = 2 \sin x$ ($-p \leq x \leq p$) egri chiziqning "tikligi" (ya'ni $|y|$) 1 dan katta bo'ladigan qismlarini aniqlang.

1059. $y = x$ va $y_1 = x + 0,01 \sin 1000px$ funksiyalar bir-biridan 0,01 dan katta bo'lmagan songa farq qiladi. Bu funksiyalar hosilalari ayirmasining maksimal qiymati haqida nima deyish mumkin? Mos grafiklarni yasang.

1060. $y = \ln x$ egri chiziq Ox o'qini qanday burchak ostida kesib o'tadi?

1061. $y = x^2$ va $x = y^2$ egri chiziqlar qanday burchaklar ostida kesishadi?

1062. $y = \sin x$ va $y = \cos x$ egri chiziqlar qanday burchaklar ostida kesishadi?

1063. n parametrlarning qanday qiymatida

$$y = \arctg nx \quad (n > 0)$$

egri chiziq Ox o'qini 89° dan katta bo'lgan burchak ostida kesib o'tadi?

1063.1. $y = |x|^a$ egri chiziq

a) $0 < a < 1$ da Oy o'qiga urinishini; b) $1 < a < +\infty$ da Ox o'qiga urinishini isbotlang.

1063.2. Ushbu

$$y = \begin{cases} |x|^a, & a \neq 0, x \neq 0, \\ 1, & x = 0 \end{cases}$$

funksiya grafigi uchun $A(0, 1)$ nuqtadan o'tuvchi kesuvchining limit holati Oy o'qi bo'lishini isbotlang.

1064. Quyidagi egri chiziq'larga ko'rsatilgan x_0 nuqtalarda o'tkazilgan chap va o'ng urinmalar orasidagi burchakni toping:

$$\text{a) } y = \sqrt{1 - e^{-a^2 x^2}}, \quad x_0 = 0; \quad \text{b) } y = \arcsin \frac{2x}{1+x^2}, \quad x_0 = 1.$$

1065. $r = ae^{mj}$ (a va m - o'zgarmas sonlar) logarifmik spiralga o'tkazilgan urinma urinish nuqtasining radius-vektori bilan o'zgarmas burchak tashkil qilishini isbotlang.

1066. $y = ax^n$ egri chiziqning urinma ostining uzunligini aniqlab, bu egri chiziqqa urinma yasash usulini ko'rsating.

1067. $y^2 = 2px$ parabolaga

a) urinma osti urinish nuqtasi abstsissasining ikkilanganiga tengligini;

b) normal osti o'zgarmas songa tengligini isbotlang.

Bu parabolaga urinma yasash usulini ko'rsating.

1068. $y = a^x$ ($a > 0$) ko'rsatkichli egri chiziq o'zgarmas urinma ostiga ega ekanligini isbotlang. Bu egri chiziqqa urinma yasash usulini ko'rsating.

1069. Ushbu

$$y = a \operatorname{ch} \frac{x}{a}$$

zanjirli chiziqqa uning ixtiyoriy $M(x_0, y_0)$ nuqtasida o'tkazilgan normalning uzunligini aniqlang.

1070. $x^{2/3} + y^{2/3} = a^{2/3}$ ($a > 0$) astroidaga o'tkazilgan urinmaning koordinata o'qlari orasidagi kesmasining uzunligi o'zgarmas songa teng ekanligini isbotlang.

1071. a, b, c koeffitsientlar orasida qanday shartlar bajarilganda $y = ax^2 + bx + c$ parabola Ox o'qiga urinadi?

1072. Qanday shartlar bajarilganda ushbu

$$y = x^3 + px + q$$

kubik parabola Ox o'qiga urinadi?

1073. a parametrning qanday qiymatida $y = ax^2$ parabola $y = \ln x$ egri chiziqqa urinadi?

1074. Agar $f(x)$ differensiallanuvchi funksiya bo'lsa, u holda

$$y = f(x) \quad (f(x) > 0) \quad \text{va} \quad y = f(x) \sin ax$$

egri chiziqlar bir-biriga umumiy nuqtalarda urinishini isbotlang.

1075. $x^2 - y^2 = a$ va $xy = b$ giperbolalar oilalari ortogonal panjara tashkil etishini isbotlang, ya'ni bu oilalardagi egri chiziqlar to'g'ri burchak ostida kesishadi.

1076. $y^2 = 4a(a - x)$ ($a > 0$) va $y^2 = 4b(b + x)$ ($b > 0$) parabolalar oilalari ortogonal panjara tashkil etishini isbotlang.

1077. Ushbu

$$x = 2t - t^2, \quad y = 3t - t^3$$

egri chiziqqa a) $t = 0$; b) $t = 1$ nuqtalarda o'tkazilgan urinma va normalning tenglamalarini tuzing.

1078. Ushbu

$$x = \frac{2t + t^2}{1 + t^3}, \quad y = \frac{2t - t^2}{1 + t^3}$$

egri chiziqqa a) $t = 0$; b) $t = 1$; v) $t = \infty$ nuqtalarda o'tkazilgan urinma va normalning tenglamalarini tuzing.

1079. Ushbu

$$x = a(t - \sin t), \quad y = a(1 - \cos t)$$

tsikloidaning ixtiyoriy $t = t_0$ nuqtasida o'tkazilgan urinmasining tenglamasini tuzing.

Bu tsikloidaga urinma yasash usulini ko'rsating.

1080. Ushbu

$$x = a \left(\ln \operatorname{tg} \frac{t}{2} + \cos t \right), \quad y = a \sin t \quad (a > 0, \quad 0 < t < \pi)$$

traktisa o'zgarmas uzunlikka ega bo'lgan urinma kesmasiga ega ekanligini isbotlang.

Quyidagi egri chiziq'larga ko'rsatilgan nuqtalarda o'tkazilgan urinma va normal tenglamalarini tuzing:

$$1081. \frac{x^2}{100} + \frac{y^2}{64} = 1, \quad M(6; 6,4).$$

$$1082. xy + \ln y = 1, \quad M(1; 1).$$

4. Funksiya differensial

1083. Ushbu

$$f(x) = x^3 - 2x + 1$$

funksiya uchun 1) $\Delta f(1)$; 2) $df(1)$ larni aniqlang va a) $\Delta x = 1$; b) $\Delta x = 0,1$; v) $\Delta x = 0,01$ bo'lganda ularni taqqoslang.

1084. Harakat tenglamasi

$$x = 5t^2$$

formula bilan berilgan, bunda t - soniyada, x - o'zgaruvchi esa metrda o'lchanadi.

$t = 2$ vaqtdagi Δx - yo'l orttirmasi va dx - yo'l differensialini aniqlang va agar: a) $\Delta t = 1$ s; b) $\Delta t = 0,1$ s; v) $\Delta t = 0,001$ s bo'lsa, ularni taqqoslang.

Quyidagi funksiyalarning differensialini toping (1085-1089):

1085. $y = \frac{1}{x}$.

1086. $y = \frac{1}{a} \operatorname{arctg} \frac{x}{a} \quad (a \neq 0)$.

1087. $y = \frac{1}{2a} \ln \left| \frac{x-a}{x+a} \right|$.

1088. $y = \ln \left| x + \sqrt{x^2 + a} \right|$.

1089. $y = \arcsin \frac{x}{a} \quad (a \neq 0)$.

1090. Toping:

a) $d(xe^x)$;

b) $d(\sin x - x \cos x)$;

v) $d\left(\frac{1}{x^3}\right)$;

g) $d\left(\frac{\ln x}{\sqrt{x}}\right)$;

d) $d(\sqrt{a^2 + x^2})$;

e) $d\left(\frac{x}{\sqrt{1-x^2}}\right)$;

j) $d \ln(1-x^2)$;

z) $d\left(\arccos \frac{1}{|x|}\right)$;

i) $d\left[\frac{\sin x}{2 \cos^2 x} + \frac{1}{2} \ln \left| \operatorname{tg} \left(\frac{x}{2} + \frac{p}{4} \right) \right| \right]$.

u, v, w - x o'zgaruvchiga nisbatan differensiallanuvchi funksiyalar bo'lsin. Quyidagi funksiyalarning differensialini toping (1091-1095):

1091. $y = uvw$.

1092. $y = \frac{u}{v^2}$.

1093. $y = \frac{1}{\sqrt{u^2 + v^2}}$.

1094. $y = \operatorname{arctg} \frac{u}{v}$.

1095. $y = \ln \sqrt{u^2 + v^2}$.

1096. Toping:

a) $\frac{d}{d(x^3)}(x^3 - 2x^6 - x^9)$;

b) $\frac{d}{d(x^2)}\left(\frac{\sin x}{x}\right)$;

v) $\frac{d(\sin x)}{d(\cos x)}$;

g) $\frac{d(\operatorname{tg} x)}{d(\operatorname{ctg} x)}$;

d) $\frac{d(\arcsin x)}{d(\arccos x)}$.

1097. Doiraviy sektorning radiusi $R = 100$ sm va markaziy burchagi $\alpha = 60^\circ$ ga teng. Agar a) uning R radiusi 1 sm ga orttirilsa; b) uning α burchagi $30'$ ga kamaytirilsa, bu sektorning yuzi qanday o'zgaradi? Aniq va taqribiy echimlar bering.

1098. Mayatnik tebranishining davri (soniyalarda)

$$T = 2\pi \sqrt{\frac{l}{g}}$$

formula bilan aniqlanadi, bunda l - mayatnikning santimetrda uzunligi, $g = 981$ sm/c² - tortishish kuchining tezlanishi.

T davr 0,05 s ga ortishi uchun mayatnikning $l = 20$ sm uzunligini qanchaga o'zgartirish kerak?

Funksiya orttirmasini differensial bilan almashtirib, quyidagilarni taqribiy hisoblang (1099-1103):

1099. $\sqrt[3]{1,02}$.

1100. $\sin 29^\circ$.

1101. $\cos 151^\circ$.

1102. $\operatorname{arctg} 1,05$.

1103. $\lg 11$.

1104. Ushbu

$$\sqrt{a^2 + x} \approx a + \frac{x}{2a} \quad (a > 0)$$

taqribiy formulani isbotlang, bunda $|x| = a$ (A va B musbat sonlar orasidagi $A = B$ munosabat A son B ga qaraganda ancha kichik degan ma`noni anglatadi).

Bu formula yordamida quyidagilarni taqribiy hisoblang:

a) $\sqrt{5}$; b) $\sqrt{34}$; v) $\sqrt{120}$

va jadvaldagi qiymatlari bilan taqqoslang.

1104.1. Ushbu

$$\sqrt{a^2 + x} = a + \frac{x}{2a} - r \quad (a > 0, x > 0)$$

formulani isbotlang, bunda $0 < r < \frac{x^3}{8a^3}$.

1105. Ushbu

$$\sqrt[n]{a^n + x} \approx a + \frac{x}{na^{n-1}} \quad (a > 0)$$

taqribiy formulani isbotlang, bunda $|x| = a$.

Bu formula yordamida quyidagilarni taqribiy hisoblang:

a) $\sqrt[3]{9}$; b) $\sqrt[4]{80}$; v) $\sqrt[7]{100}$; g) $\sqrt[10]{1000}$.

1106. Kvadratning tomoni $x = 2,4 \text{ m} \pm 0,05 \text{ m}$ ga teng. Bu kvadratning yuzini qanday absolyut va nisbiy xatoliklar bilan hisoblash mumkin?

1107. SHarning hajmini 1 % aniqlikkacha hisoblash uchun uning R radiusini qanday nisbiy xatolik bilan o`lchash mumkin?

1108. Mayatnikning tebranishi yordamida tortishish kuchining tezlanishini aniqlash maqsadida $g = 4p^2l/T^2$ formuladan foydalaniladi, bunda l - mayatnik uzunligi, T - mayatnik tebranishining to`la davri. a) l uzunlikni; b) T davrni o`lchashda d nisbiy xatolik g ning qiymatiga qanday ta`sir qiladi?

1109. Agar $x(x > 0)$ sonning nisbiy xatoligi d ga teng bo`lsa, bu son o`nli logarifmining absolyut xatoligini aniqlang.

1110. Logarifmik jadval bo`yicha burchaklarning tangenslari o`nli xonalari bir xil bo`lganda sinuslarning logarifmik jadvaliga qaraganda aniqroq hisoblanishini isbotlang.

5. YUqori tartibli hosila va differensiallar

Quyidagi funksiyalar uchun y'' ni toping (1111-1119):

1111. $y = x\sqrt{1+x^2}$.

1112. $y = \frac{x}{\sqrt{1-x^2}}$.

1113. $y = e^{-x^2}$.

$$1114. y = tg x. \quad 1115. y = (1+x^2) arctg x. \quad 1116. y = \frac{\arcsin x}{\sqrt{1-x^2}}.$$

$$1117. y = x \ln x \quad 1118. y = \ln f(x).$$

$$1119. y = x[\sin(\ln x) + \cos(\ln x)]$$

1120. Agar

$$y = e^{\sin x} \cos(\sin x)$$

bo`lsa, $y(0)$, $y'(0)$ va $y''(0)$ larni toping.

$u = j(x)$ va $v = y(x)$ - ikki marta differensiallanuvchi funksiyalar bo`lsin. y'' ni toping, agar:

$$1121. y = u^2.$$

$$1122. y = \ln \frac{u}{v}.$$

$$1123. y = \sqrt{u^2 + v^2}.$$

$$1124. y = u^v \quad (u > 0).$$

$f(x)$ - uch marta differensiallanuvchi funksiya bo`lsin. y'' va y''' larni toping, agar:

$$1125. y = f(x^2).$$

$$1126. y = f\left(\frac{1}{x}\right).$$

$$1127. y = f(e^x).$$

$$1128. y = f(\ln x).$$

1129. $y = f(j(x))$, bunda $j(x)$ - etarlicha marta differensiallanuvchi funksiya.

1130. $y = e^x$ funksiya uchun quyidagi ikki holda $d^2 y$ ni toping: a) x - erkli o`zgaruvchi, b) x - oraliq argument.

x ni erkli o`zgaruvchi deb hisoblab, quyidagi funksiyalar uchun $d^2 y$ ni toping:

$$1131. y = \sqrt{1+x^2}.$$

$$1132. y = \frac{\ln x}{x}.$$

$$1133. y = x^2.$$

u va v - ikki marta differensiallanuvchi x ning funksiyalari bo`lsin. $d^2 y$ ni toping, agar:

$$1134. y = uu.$$

$$1135. y = \frac{u}{v}.$$

$$1136. y = u^m v^n \quad (m, n = const).$$

$$1137. y = a^u \quad (a > 0).$$

$$1138. y = \ln \sqrt{u^2 + v^2}.$$

$$1139. y = arctg \frac{u}{v}.$$

Quyidagi parametrik usulda berilgan funksiyalar uchun y'_x , y''_{x^2} , y'''_{x^3} larni toping:

$$1140. x = 2t - t^2, \quad y = 3t - t^3.$$

$$1141. x = a \cos t, \quad y = a \sin t.$$

$$1142. x = a(t - \sin t), \quad y = a(1 - \cos t).$$

$$1143. x = e^t \cos t, \quad y = e^t \sin t.$$

$$1144. x = f'(t), \quad y = tf'(t) - f(t).$$

1145. $y = f(x)$ funksiya etarlicha marta differensiallanuvchi funksiya bo`lsin. Unga teskari bo`lgan $x = f^{-1}(y)$ funksiya uchun x' , x'' , x''' hosilalarni toping (bu hosilalar mavjud deb faraz qilamiz).

Quyidagi oshkormas funksiyalarning y'_x , y''_{x^2} , y'''_{x^3} hosilalarini toping:

$$1146. x^2 + y^2 = 25. \quad M(3, 4) \text{ nuqtadagi } y', y'', y''' \text{ hosilalarning qiymatini toping.}$$

$$1147. y^2 = 2px.$$

$$1148. x^2 - xy + y^2 = 1.$$

y'_x , y''_{x^2} hosilalarini toping:

$$1149. y^2 + 2 \ln y = x^4.$$

$$1150. \sqrt{x^2 + y^2} = ae^{arctg y/x} \quad (a > 0).$$

1151. $f(x)$ funksiya $x \leq x_0$ da aniqlangan va ikki marta differensiallanuvchi funk-tsiya bo`lsin. Ushbu

$$F(x) = \begin{cases} f(x), & x \leq x_0; \\ a(x-x_0)^2 + b(x-x_0) + c, & x > x_0 \end{cases}$$

funksiya ikki marta differensiallanuvchi bo`lishi uchun a, b va c koeffitsientlarni qan-day tanlash kerak?

1152. Nuqta ushbu

$$s = 10 + 20t - 5t^2$$

qonun bo`yicha to`g`ri chiziqli harakatlanmoqda. Harakatning tezligi va tezlanishini toping. $t = 2$ vaqtdagi tezlik va tezlanish nimaga teng?

1153. $M(x, y)$ nuqta $x^2 + y^2 = a^2$ aylana bo`ylab, uni T s ichida bir marta to`la aylanib, tekis harakat qilmoqda. Agar $t = 0$ da berilgan nuqta $M_0(a, 0)$ holatda bo`lsa, u holda uning Ox o`qiga proektsiyasining v tezligini va j tezlanishini toping.

1154. $M(x, y)$ og`ir material nuqta Oxy vertikal tekislikda gorizont tekisligiga α burchak ostida boshlang`ich v_0 tezlik bilan tashlab yuborildi. Harakat tenglamasini (havo qarshiligini hisobga olmagan holda) tuzing va v tezlikni, j tezlanishni hamda harakat traektoriyasini aniqlang. Nuqtaning eng katta ko`tarilish balandligi va uchish masofasi nimaga teng?

1155. Nuqtaning harakat tenglamasi

$$x = 4 \sin wt - 3 \cos wt, \quad y = 3 \sin wt + 4 \cos wt, \quad (w = \text{const})$$

formula bilan berilgan. Harakat traektoriyasini, tezlikni hamda tezlanishni aniqlang.

Quyidagi funksiyalar uchun ko`rsatilgan tartibli hosilalarni toping (1156-1170):

1156. $y = x(2x-1)^2(x+3)^3$, $y^{(6)}$ va $y^{(7)}$.

1157. $y = \frac{a}{x^m}$, $y^{(m)}$.

1158. $y = \sqrt{x}$, $y^{(10)}$.

1159. $y = \frac{x^2}{1-x}$, $y^{(8)}$.

1160. $y = \frac{1+x}{\sqrt{1-x}}$, $y^{(100)}$.

1161. $y = x^2 e^{2x}$, $y^{(20)}$.

1162. $y = \frac{e^x}{x}$, $y^{(10)}$.

1163. $y = x \ln x$, $y^{(5)}$.

1164. $y = \frac{\ln x}{x}$, $y^{(5)}$.

1165. $y = x^2 \sin 2x$, $y^{(50)}$.

1166. $y = \frac{\cos 3x}{\sqrt[3]{1-3x}}$, $y^{(m)}$.

1167. $y = \sin x \sin 2x \sin 3x$, $y^{(10)}$.

1168. $y = x \operatorname{sh} x$, $y^{(100)}$.

1169. $y = e^x \cos x$, $y^{(V)}$.

1170. $y = \sin^2 x \ln x$, $y^{(6)}$.

Quyidagi misollarda, x ni erkli o`zgaruvchi deb hisoblab, ko`rsatilgan tartibli differensiallarni toping (1171-1175):

1171. $y = x^5$, $d^5 y$.

1172. $y = 1/\sqrt{x}$, $d^3 y$.

1173. $y = x \cos 2x$, $d^{10} y$.

1174. $y = e^x \ln x$, $d^4 y$.

1175. $y = \cos x \cdot \operatorname{ch} x$, $d^6 y$.

Quyidagi misollarda, agar u - x ning funksiyasi bo`lib, etarlicha marta differensiallanuvchi bo`lsa, ko`rsatilgan tartibli differensiallarni toping (1176-1178):

1176. $y = u^2$, $d^{10} y$.

1177. $y = e^u$, $d^4 y$.

1178. $y = \ln u$, $d^3 y$.

1179. $y = f(x)$ uchun d^2y , d^3y , d^4y larni toping, bunda x - biror erkli o'zgaruvchi-ning funksiyasi.

1180. x ni erkli o'zgaruvchi deb hisoblamay, $y = f(x)$ funksiyaning y'' , y''' hosilalarini x va y o'zgaruvchilarning ketma-ket differensiallari orqali ifodalang.

1181. $y = C_1 \cos x + C_2 \sin x$ funksiya (C_1 va C_2 - ixtiyoriy o'zgarmas sonlar) ushbu

$$y'' + y = 0$$

tenglamani qanoatlantirishini ko'rsating.

1182. $y = C_1 \operatorname{ch} x + C_2 \operatorname{sh} x$ funksiya (C_1 va C_2 - ixtiyoriy o'zgarmas sonlar) ushbu

$$y'' - y = 0$$

tenglamani qanoatlantirishini ko'rsating.

1183. $y = C_1 e^{I_1 x} + C_2 e^{I_2 x}$ funksiya (C_1 va C_2 - ixtiyoriy o'zgarmas sonlar, I_1, I_2 - o'zgarmas sonlar) ushbu

$$y'' - (I_1 + I_2)y' + I_1 I_2 y = 0$$

tenglamani qanoatlantirishini ko'rsating.

1184. Ushbu

$$y = x^n [C_1 \cos(\ln x) + C_2 \sin(\ln x)]$$

funksiya (C_1 va C_2 - ixtiyoriy o'zgarmas sonlar, n - o'zgarmas son) ushbu

$$x^2 y'' + (1 - 2n)xy' + (1 + n^2)y = 0$$

tenglamani qanoatlantirishini ko'rsating.

1185. Ushbu

$$y = e^{x/\sqrt{2}} \left(C_1 \cos \frac{x}{\sqrt{2}} + C_2 \sin \frac{x}{\sqrt{2}} \right) + e^{-x/\sqrt{2}} \left(C_3 \cos \frac{x}{\sqrt{2}} + C_4 \sin \frac{x}{\sqrt{2}} \right)$$

funksiya (C_1, C_2, C_3, C_4 - ixtiyoriy o'zgarmas sonlar) ushbu

$$y^{IV} + y = 0$$

tenglamani qanoatlantirishini ko'rsating.

1186. Agar $f(x)$ funksiya n -tartibli hosilaga ega bo'lsa, u holda

$$[f(ax + b)]^{(n)} = a^n f^{(n)}(ax + b)$$

formulani isbotlang.

1187. Agar $P(x) = a_0 x^n + a_1 x^{n-1} + \dots + a_n$ bo'lsa, $P^{(n)}(x)$ ni toping.

Quyidagi funksiyalar uchun $y^{(n)}$ ni toping (1188-1210):

1188. $y = \frac{ax + b}{cx + d}$.

1189. $y = \frac{1}{x(1-x)}$.

1190. $y = \frac{1}{x^2 - 3x + 2}$. Y o`l l a n m a. Funksiyani oddiy kasrlarga yoying.

1191. $y = \frac{1}{\sqrt{1-2x}}$.

1192. $y = \frac{x}{\sqrt[3]{1+x}}$.

1193. $y = \sin^2 x$.

1194. $y = \cos^2 x$.

1195. $y = \sin^3 x$.

1196. $y = \cos^3 x$.

1197. $y = \sin ax \sin bx$.

1198. $y = \cos ax \cos bx$.

1199. $y = \sin ax \cos bx$.

1200. $y = \sin^2 ax \cos bx$.

1201. $y = \sin^4 x + \cos^4 x$.

1202. $y = x \cos ax$.

1203. $y = x^2 \sin ax$.

1204. $y = (x^2 + 2x + 2)e^{-x}$.

$$1205. y = e^x/x.$$

$$1206. y = e^x \cos x.$$

$$1207. y = e^x \sin x.$$

$$1208. y = \ln \frac{a+bx}{a-bx}.$$

$$1209. y = e^{ax} P(x), P(x) - \text{ko`phad.}$$

$$1210. y = x \operatorname{sh} x.$$

$d^n y$ ni toping (1211-1212):

$$1211. y = x^n e^x.$$

$$1212. y = \frac{\ln x}{x}.$$

1213. Tengliklarni isbotlang:

$$1) [e^{ax} \sin(bx+c)]^{(n)} = e^{ax} (a^2 + b^2)^{n/2} \sin(bx+c+nj),$$

$$2) [e^{ax} \cos(bx+c)]^{(n)} = e^{ax} (a^2 + b^2)^{n/2} \cos(bx+c+nj),$$

bunda $\sin j = \frac{b}{\sqrt{a^2 + b^2}}, \quad \cos j = \frac{a}{\sqrt{a^2 + b^2}}.$

1214. $y^{(n)}$ ni toping:

a) $y = \operatorname{ch} ax \cos bx;$

b) $y = \operatorname{ch} ax \sin bx.$

1215. $f(x) = \sin^{2p} x$ ($p \in N$) funksiyani ushbu

$$f(x) = \sum_{k=0}^p A_k \cos 2kx$$

trigonometrik ko`phadga almashtirib, $f^{(n)}(x)$ ni toping.

Yo`llanma. $\sin x = \frac{1}{2i}(t - \bar{t})$ deb olib, bunda $t = \cos x + i \sin x$ va $\bar{t} = \cos x - i \sin x$,

Muavr formulasidan foydalaning.

1216. Agar

a) $f(x) = \sin^{2p+1} x;$

b) $f(x) = \cos^{2p} x;$

v) $f(x) = \cos^{2p+1} x$

bo`lsa, $f^{(n)}(x)$ ni toping, bunda p - butun musbat son (avvalgi masalaga qarang).

Agar

$$f(x) = f_1(x) + if_2(x)$$

bo`lsa, bunda i - mavhum bir va $f_1(x), f_2(x)$ - x haqiqiy o`zgaruvchiga nisbatan haqiqiy funksiyalar, u holda ta`rif bo`yicha

$$f'(x) = f_1'(x) + if_2'(x)$$

bo`ladi.

1217. Ushbu

$$\frac{1}{x^2 + 1} = \frac{1}{2i} \left(\frac{1}{x-i} - \frac{1}{x+i} \right)$$

ayniyatdan foydalanib,

$$\left(\frac{1}{x^2 + 1} \right)^{(n)} = \frac{(-1)^n n!}{(1+x^2)^{(n+1)/2}} \sin[(n+1) \operatorname{arctg} x]$$

formulani isbotlang.

Yo`llanma. Muavr formulasini qo`llang.

1218. $f(x) = \operatorname{arctg} x$ funksiya uchun $f^{(n)}(x)$ ni toping.

Quyidagi funksiyalar uchun $f^{(n)}(0)$ ni toping (1219-1222):

$$1219. a) f(x) = \frac{1}{(1-2x)(1+x)};$$

$$b) f(x) = \frac{x}{\sqrt{1-x}}.$$

$$1220. a) f(x) = x^2 e^{ax}; \quad b) f(x) = \arctg x; \quad v) f(x) = \arcsin x.$$

$$1221. a) f(x) = \cos(m \arcsin x); \quad b) f(x) = \sin(m \arcsin x).$$

$$1222. a) f(x) = (\arctg x)^2; \quad b) f(x) = (\arcsin x)^2.$$

1223. Agar

$$f(x) = (x-a)^n j(x)$$

bo'lsa, bunda $j(x)$ funksiya a nuqtaning atrofida $(n-1)$ - tartibli uzluksiz hosilaga ega, $f^{(n)}(a)$ ni toping.

1224. Ushbu

$$f(x) = \begin{cases} x^{2n} \sin \frac{1}{x}, & x \neq 0, \\ 0, & x = 0 \end{cases}$$

funksiya ($n \in N$) $x=0$ nuqtada $1, 2, \dots, n$ - tartibli hosilalarga ega va $(n+1)$ - tartibli hosilaga ega emasligini isbotlang.

1225. Ushbu

$$f(x) = \begin{cases} e^{-1/x^2}, & x \neq 0, \\ 0, & x = 0 \end{cases}$$

funksiya cheksiz ko'p marta differensiallanuvchi ekanligini isbotlang.

Bu funksiya grafigini yasang.

1226. Quyidagi

$$T_m(x) = \frac{1}{2^{m-1}} \cos(m \arccos x) \quad (m = 1, 2, \dots)$$

CHebishev ko'phadlari ushbu

$$(1-x^2)T_m''(x) - xT_m'(x) + m^2T_m(x) = 0$$

tenglamani qanoatlantirishini isbotlang.

1227. Quyidagi

$$P_m(x) = \frac{1}{2^m m!} [(x^2-1)^m]^{(m)} \quad (m = 0, 1, 2, \dots)$$

Lejandr ko'phadlari ushbu

$$(1-x^2)P_m''(x) - 2xP_m'(x) + m(m+1)P_m(x) = 0$$

tenglamani qanoatlantirishini isbotlang.

Y o`l l a n m a. $(x^2-1)u' = 2mxu$ tenglikni $m+1$ - marta differensiallang, bunda $u = (x^2-1)^m$.

1228. CHebishev-Lagerra ko'phadlari ushbu

$$L_m(x) = e^x (x^m e^{-x})^{(m)} \quad (m = 0, 1, 2, \dots)$$

formula orqali aniqlanadi.

$L_m(x)$ ko'phadning oshkor ko'rinishdagi ifodasini toping va bu ko'phad ushbu

$$xL_m''(x) + (1-x)L_m'(x) + mL_m(x) = 0$$

tenglamani qanoatlantirishini isbotlang.

Y o`l l a n m a. $xu' + (x-m)u = 0$ tenglikdan foydalaning, bunda $u = x^m e^{-x}$.

1229. n marta differensiallanuvchi $f(u)$ va $j(x)$ funksiyalar uchun $y = f(u)$ va $u = j(x)$ bo'lsin. U holda ushbu

$$\frac{d^n y}{dx^n} = \sum_{k=1}^n A_k(x) f^{(k)}(u)$$

tenglikni isbotlang, bunda $A_k(x)$ ($k = 0, 1, \dots, n$) koeffitsientlar $f(u)$ funksiyaga bog'liq emas.

1230. $y = f(x^2)$ murakkab funksiyaning n - tartibli hosilasi uchun quyidagi formula o'rinli ekanligini isbotlang:

$$\begin{aligned} \frac{d^n y}{dx^n} &= (2x)^n f^{(n)}(x^2) + \frac{n(n-1)}{1!} (2x)^{n-2} f^{(n-1)}(x^2) + \\ &+ \frac{n(n-1)(n-2)(n-3)}{2!} (2x)^{n-4} f^{(n-2)}(x^2) + \dots \end{aligned}$$

1231. Chebishev-Ermit ko'phadlari ushbu

$$H_m(x) = (-1)^m e^{x^2} (e^{-x^2})^{(m)} \quad (m = 0, 1, 2, \dots)$$

formula orqali aniqlanadi.

$H_m(x)$ ko'phadning oshkor ko'rinishdagi ifodasini toping va bu ko'phad ushbu

$$H_m''(x) - 2xH_m'(x) + 2mH_m(x) = 0$$

tenglamani qanoatlantirishini isbotlang.

Yo'llanma. $u' + 2xu = 0$ tenglikdan foydalaning, bunda $u = e^{-x^2}$.

1232. Tenglikni isbotlang:

$$(x^{n-1} e^{1/x})^{(n)} = \frac{(-1)^n}{x^{n+1}} e^{1/x}.$$

Yo'llanma. Matematik induksiya usulini qo'llang.

1232.1. Formulani isbotlang:

$$\frac{d^n}{dx^n} (x^n \ln x) = n! \left(\ln x + \sum_{k=1}^n \frac{1}{k} \right) \quad (x > 0).$$

1232.2. Formulani isbotlang:

$$\frac{d^{2n}}{dx^{2n}} \left(\frac{\sin x}{x} \right) = \frac{(2n)!}{x^{2n+1}} [C_n(x) \sin x - S_n(x) \cos x],$$

bunda $C_n(x) = 1 - \frac{x^2}{2!} + \dots + (-1)^n \frac{x^{2n}}{(2n)!}$ va $S_n(x) = x - \frac{x^3}{3!} + \dots + (-1)^{n-1} \frac{x^{2n-1}}{(2n-1)!}$.

1233. Differensiallash amalini $\frac{d}{dx} = D$ kabi belgilaylik va

$$f(D) = \sum_{k=0}^n p_k(x) D^k$$

ifodani shartli ravishda differensial ko'phad deylik, bunda $p_k(x)$ ($k = 0, 1, \dots, n$) - ba'zi bir uzluksiz funksiyalar. U holda quyidagini isbotlang:

$$f(D)\{e^{Ix}u(x)\} = e^{Ix}f(D+I)u(x) \quad (I = \text{const}).$$

1234. Agar

$$\sum_{k=0}^n a_k x^k y_x^{(k)} = 0$$

tenglamada $x = e^t$ deb olsak, bunda t - erkli o'zgaruvchi, u holda tenglama ushbu

$$\sum_{k=0}^n a_k D(D-1)\dots(D-k+1)y = 0$$

ko`rinishga kelishini isbotlang, bunda $D = \frac{d}{dt}$.

6. Roll', Lagranj va Koshi teoremlari

1235. Quyidagi funksiya uchun Roll' teoremasining o`rinli ekanligini tekshiring:

$$f(x) = (x-1)(x-2)(x-3).$$

1236. $f(x) = 1 - \sqrt[3]{x^2}$ funksiya $x_1 = -1$ va $x_2 = 1$ nuqtalarda nolga teng, lekin $-1 \leq x \leq 1$ da $f'(x) \neq 0$. Bu narsa Roll' teoremasiga zid kelayotgandek tuyuladi. Roll' teoremasidagi ziddiyatni tushuntiring.

1237. $f(x)$ funksiya chekli yoki cheksiz (a, b) intervalning har bir nuqtasida $f'(x)$ hosilaga ega bo`lsin va

$$\lim_{x \rightarrow a+0} f(x) = \lim_{x \rightarrow b-0} f(x)$$

bo`lsin. U holda $f'(c) = 0$ ni isbotlang, bunda $c - (a, b)$ intervalning biror nuqtasi.

1238. Agar: 1) $f(x)$ funksiya $[x_0, x_n]$ kesmada aniqlangan va $(n-1)$ - tartibli $f^{(n-1)}(x)$ hosilaga ega; 2) $f(x)$ funksiya (x_0, x_n) intervalda n - tartibli $f^{(n)}(x)$ hosilaga ega; 3) ushbu

$$f(x_0) = f(x_1) = \dots = f(x_n) \quad (x_0 < x_1 < \dots < x_n)$$

tengliklar bajarilsa, u holda (x_0, x_n) intervalda $f^{(n)}(x) = 0$ tenglik bajariladigan hech bo`lmaganda bitta x nuqta mavjud ekanligini isbotlang.

1239. Agar: 1) $f(x)$ funksiya $[a, b]$ kesmada aniqlangan va $(p+q)$ - tartibli $f^{(p+q)}(x)$ hosilaga ega; 2) $f(x)$ funksiya (a, b) intervalda $(p+q+1)$ - tartibli $f^{(p+q+1)}(x)$ hosilaga ega; 3) ushbu

$$f(a) = f'(a) = \dots = f^{(p)}(a) = 0, \quad f(b) = f'(b) = \dots = f^{(q)}(b) = 0$$

tengliklar o`rinli bo`lsa, u holda $f^{(p+q+1)}(c) = 0$ ekanligini isbotlang, bunda $c - (a, b)$ intervalning biror nuqtasi.

1240. Agar a_k ($k = 0, 1, \dots, n$) haqiqiy koeffitsientli

$$P_n(x) = a_0 x^n + a_1 x^{n-1} + \dots + a_n \quad (a_0 \neq 0)$$

ko`phadning barcha ildizlari haqiqiy bo`lsa, u holda uning $P_n'(x)$, $P_n''(x)$, \dots , $P_n^{(n-1)}(x)$ ketma-ket olingan hosilalari ham faqat haqiqiy ildizlarga ega ekanligini isbotlang.

1241. Ushbu

$$P_n(x) = \frac{1}{2^n n!} \frac{d^n}{dx^n} \left\{ (x^2 - 1)^n \right\}$$

Lejandr ko`phadining barcha ildizlari haqiqiy va $(-1, 1)$ oraliqda yotishini isbotlang.

1242. Ushbu

$$L_n(x) = e^x \frac{d^n}{dx^n} (x^n e^{-x})$$

CHebishev-Lagerra ko`phadining barcha ildizlari musbat ekanligini isbotlang.

1243. Ushbu

$$H_n(x) = (-1)^n e^{x^2} \frac{d^n}{dx^n} (e^{-x^2})$$

Chebyshev-Ermit ko'phadining barcha ildizlari haqiqiy ekanligini isbotlang.

1244. $y = x^3$ egri chiziqda shunday nuqta topingki, bu nuqtadagi urinma $A(-1, -1)$ $B(2, 8)$ nuqtalarni tutashtiruvchi vatarga parallel bo'lsin.

1245. Agar $ab < 0$ bo'lsa, u holda $[a, b]$ kesmada $f(x) = 1/x$ funksiya uchun chekli orttirmalar formulasi o'rinli bo'ladimi?

1246. Agar:

a) $f(x) = ax^2 + bx + c$ ($a \neq 0$); b) $f(x) = x^3$; v) $f(x) = 1/x$; g) $f(x) = e^x$

bo'lsa, u holda

$$f(x + \Delta x) - f(x) = \Delta x f'(x + q\Delta x) \quad (0 < q < 1)$$

tenglik bajariladigan $q = q(x, \Delta x)$ funksiyani toping.

1246.1. $f(x) \in C^{(1)}(-\infty, +\infty)$ va

$$f(x+h) - f(x) \equiv hf'(x)$$

bo'lsin. U holda $f(x) = ax + b$ ekanligini isbotlang, bunda a va b - o'zgarmas sonlar.

1246.2. $f(x) \in C^{(2)}(-\infty, +\infty)$ va

$$f(x+h) - f(x) \equiv hf' \left(x + \frac{h}{2} \right)$$

bo'lsin. U holda $f(x) = ax^2 + bx + c$ ekanligini isbotlang, bunda a , b va c - o'zgarmas sonlar.

1247. Agar $x \geq 0$ bo'lsa, u holda

$$\sqrt{x+1} - \sqrt{x} = \frac{1}{2\sqrt{x+q(x)}}$$

ekanligini isbotlang, bunda

$$\frac{1}{4} \leq q(x) \leq \frac{1}{2}$$

va $\lim_{x \rightarrow +0} q(x) = 1/4$, $\lim_{x \rightarrow +\infty} q(x) = 1/2$.

1248. Ushbu

$$f(x) = \begin{cases} \frac{3-x^2}{2}, & 0 \leq x \leq 1, \\ \frac{1}{x}, & 1 < x < +\infty \end{cases}$$

funksiya uchun $[0, 2]$ kesmada chekli orttirmalar formulasining c oraliq qiymatini toping.

1249. $f(x) - f(0) = xf'(x(x))$ bo'lsin, bunda $0 < x(x) < x$. Agar $x > 0$ da

$$f(x) = x \sin(\ln x)$$

va $f(0) = 0$ bo'lsa, u holda $x = x(x)$ funksiya ixtiyoriy etarlicha kichik $(0, x)$ intervalda uzilishga ega ekanligini isbotlang, bunda $e > 0$.

1250. $f(x)$ funksiya (a, b) intervalda uzluksiz $f'(x)$ hosilaga ega bo'lsin. (a, b) intervalda yotuvchi ixtiyoriy nuqta uchun shu intervalda yotuvchi va ushbu

$$\frac{f(x_2) - f(x_1)}{x_2 - x_1} = f'(x) \quad (x_1 < x < x_2)$$

tenglikni qanoatlantiruvchi x_1 va x_2 nuqtalar topish mumkinmi?

Quyidagi misolni ko'ring: $f(x) = x^3$ ($-1 \leq x \leq 1$), bunda $x = 0$.

1251. Tengsizliklarni isbotlang:

a) $|\sin x - \sin y| \leq |x - y|$;

b) $py^{p-1}(x-y) \leq x^p - y^p \leq px^{p-1}(x-y)$, agar $0 < y < x$, $p > 1$;

v) $|\arctg a - \arctg b| \leq |a - b|$; g) $\frac{a-b}{a} < \ln \frac{a}{b} < \frac{a-b}{b}$, agar $0 < b < a$.

1252. $f(x) = x^2$ va $g(x) = x^3$ funksiyalar uchun $[-1, 1]$ kesmada Koshi formulasi nima uchun o'rinli emasligini tushuntiring.

1253. $f(x)$ funksiya $[x_1, x_2]$ kesmada differensiallanuvchi va $x_1 x_2 > 0$ bo'lsin. U holda

$$\frac{1}{x_1 - x_2} \left| \begin{array}{cc} x_1 & x_2 \\ f(x_1) & f(x_2) \end{array} \right| = f(x) - x f'(x)$$

tenglikni isbotlang, bunda $x_1 < x < x_2$.

1254. Agar $f(x)$ funksiya chekli (a, b) intervalda differensiallanuvchi, lekin shu intervalda chegaralanmagan bo'lsa, u holda uning $f'(x)$ hosilasi ham (a, b) intervalda chegaralanmaganligini isbotlang. Bunga teskari teorema no'rin(misol quring).

1255. Agar $f(x)$ funksiya chekli yoki cheksiz (a, b) intervalda chegaralangan $f'(x)$ hosilaga ega bo'lsa, u holda $f(x)$ funksiya (a, b) intervalda tekis uzluksiz ekanligini isbotlang.

1256. Agar $f(x)$ funksiya cheksiz $(x_0, +\infty)$ intervalda differensiallanuvchi va $\lim_{x \rightarrow +\infty} f'(x) = 0$ bo'lsa, u holda $\lim_{x \rightarrow +\infty} \frac{f(x)}{x} = 0$, ya'ni $x \rightarrow +\infty$ da $f(x) = o(x)$.

1257. Agar $f(x)$ funksiya cheksiz $(x_0, +\infty)$ intervalda differensiallanuvchi va $x \rightarrow +\infty$ da $f(x) = o(x)$ bo'lsa, u holda

$$\lim_{x \rightarrow +\infty} |f'(x)| = 0$$

tenglikni isbotlang. Xususan, agar $\lim_{x \rightarrow +\infty} f'(x) = k$ mavjud bo'lsa, u holda $k = 0$.

1258. a) Agar: 1) $f(x)$ funksiya $[x_0, X]$ kesmada aniqlangan va uzluksiz; 2) $f(x)$ funksiya (x_0, X) intervalda chekli $f'(x)$ hosilaga ega; 3) chekli yoki cheksiz $\lim_{x \rightarrow x_0+0} f'(x) = f'(x_0+0)$ limit mavjud bo'lsa, u holda mos ravishda chekli yoki cheksiz bir tomonlama $f'_+(x_0)$ hosila mavjud va $f'_+(x_0) = f'(x_0+0)$ ekanligini isbotlang.

b) Ushbu

$$f(x) = \arctg \frac{1+x}{1-x} \quad (x \neq 1), \quad f(1) = 0$$

funksiya uchun chekli $\lim_{x \rightarrow 1} f'(x)$ limit mavjud, lekin $f(x)$ funksiya $f'_-(1)$ va $f'_+(1)$ bir tomonlama hosilalarga ega emasligini isbotlang. Bu tasdiqning geometrik illyustratsiya-sini bering.

Vaholanki, bu nuqtada umumlashgan hosilalar mavjud(1009.1-misolga qarang).

1259. Agar $a < x < b$ da $f'(x) = 0$ bo'lsa, u holda

$$f(x) = const, \quad a < x < b$$

ekanligini isbotlang.

1260. O'zgarma songa teng $f'(x) = k$ hosilaga ega bo'lgan yagona $f(x)$ ($-\infty < x < +\infty$) funksiya bu - $f(x) = kx + b$ chiziqli funksiya ekanligini isbotlang.

1261. Agar $f^{(n)}(x) = 0$ bo'lsa, $f(x)$ funksiya haqida nima deyish mumkin?

1261.1. Agar $f(x) \in C^{(\infty)}(-\infty, +\infty)$ va ixtiyoriy x uchun $f^{(n_x)}(x) = 0$ tenglik bajariladigan natural n_x ($n_x \leq n$) son mavjud bo'lsa, u holda $f(x)$ funksiya polinom ekanligini isbotlang.

1262. Ushbu

$$y' = I y \quad (I = \text{const})$$

tenglamani qanoatlantiruvchi yagona $y = y(x)$ ($-\infty < x < +\infty$) funksiya - bu $y = C e^{Ix}$ ko'rsatkichli funksiya ekanligini isbotlang, bunda C - o'zgarma son.

Yo'llanma. $(y e^{-Ix})'$ ni ko'ring.

1263. $f(x) = \text{arctg} \frac{1+x}{1-x}$ va $g(x) = \text{arctg} x$ funksiyalar 1) $x < 1$ va 2) $x > 1$ sohalarda bir xil hosilaga ega ekanligini tekshiring.

Bu funksiyalar orasidagi bog'lanishni keltirib chiqaring.

1264. Ayniyatlarni isbotlang:

a) $2 \text{arctg} x + \arcsin \frac{2x}{1+x^2} = p \text{sgn} x, |x| \geq 1;$

b) $3 \arccos x - \arccos(3x - 4x^3) = p, |x| \leq \frac{1}{2}.$

1265. Agar: 1) $f(x)$ funksiya $[a, b]$ kesmada uzluksiz; 2) uning ichida chekli $f'(x)$ hosilaga ega; 3) chiziqli bo'lmasa, u holda (a, b) intervalda

$$|f'(c)| > \left| \frac{f(b) - f(a)}{b - a} \right|$$

tengsizlik bajariladigan hech bo'lmaganda bitta c nuqta mavjud ekanligini isbotlang.

Bu tasdiqning geometrik illyustratsiyasini bering.

1266. Agar: 1) $f(x)$ funksiya $[a, b]$ kesmada 2-tartibli $f''(x)$ hosilaga ega va 2) $f'(a) = f'(b) = 0$ bo'lsa, u holda (a, b) intervalda

$$|f''(c)| \geq \frac{4}{(b-a)^2} |f(b) - f(a)|$$

tengsizlik bajariladigan hech bo'lmaganda bitta c nuqta mavjud ekanligini isbotlang.

1267. Avtomobil' biror boshlang'ich punktdan harakatni boshlab, t s dan keyin S m masofani bosib o'tib harakatini to'xtatdi. Qandaydir vaqtda avtomobil' harakatidagi tezlanishning absolyut qiymati $4s/t^2$ m/s² dan kichik bo'lmaganini isbotlang.

7. Funksiyaning o'sish va kamayishi. Tengsizliklar

Quyidagi funksiyalarning qat'iy monotonlik (o'sish yoki kamayish) oraliqlarini toping (1268-1278):

1268. $y = 2 + x - x^2.$

1269. $y = 3x - x^3.$

1270. $y = \frac{2x}{1+x^2}.$

1271. $y = \frac{\sqrt{x}}{x+100} \quad (x \geq 0).$

1272. $y = x + \sin x.$

1273. $y = x + |\sin 2x|.$

$$1274. y = \cos \frac{p}{x}.$$

$$1275. y = \frac{x^2}{2^x}.$$

$$1276. y = x^n e^{-x} \quad (n > 0, x \geq 0).$$

$$1277. y = x^2 - \ln x^2.$$

$$1278. x > 0 \text{ da } f(x) = x \left(\sqrt{\frac{3}{2}} + \sin \ln x \right) \text{ va } f(0) = 0.$$

1279. Aylanaga ichki chizilgan muntazam n -burchakning n tomonlari soni orttirilsa, uning p_n perimetri o'sishini, shu aylanaga tashqi chizilgan muntazam n -burchakning P_n perimetri esa kamayishini isbotlang. Bundan foydalanib, p_n va P_n lar $n \rightarrow \infty$ da umumiy limitga ega ekanligini isbotlang.

1280. Ushbu

$$f(x) = \left(1 + \frac{1}{x} \right)^x$$

funksiya $(-\infty, -1)$ va $(0, +\infty)$ oraliqlarda o'suvchi ekanligini isbotlang.

1281. Ushbu

$$P(x) = a_0 + a_1 x + \dots + a_n x^n \quad (n \geq 1, a_n \neq 0)$$

butun ratsional funksiya $(-\infty, -x_0)$ va $(x_0, +\infty)$ oraliqlarda monoton (qat'iy ma'noda) ekanligini isbotlang, bunda x_0 - etarlicha katta musbat son.

1282. Ushbu

$$R(x) = \frac{a_0 + a_1 x + \dots + a_n x^n}{b_0 + b_1 x + \dots + b_m x^m} \quad (a_n b_m \neq 0)$$

o'zgarmas songa aynan teng bo'lmagan ratsional funksiya $(-\infty, -x_0)$ va $(x_0, +\infty)$ interval-larda monoton (qat'iy ma'noda) ekanligini isbotlang, bunda x_0 - etarlicha katta musbat son.

1283. Monoton funksiyaning hosilasi albatta monoton bo'lishi shartmi? Ushbu misolni ko'ring: $f(x) = x + \sin x$.

1284. Agar $j(x)$ - monoton o'suvchi differensiallanuvchi funksiya bo'lsa va $x \geq x_0$ da

$$|f'(x)| \leq j'(x)$$

tengsizlik bajarilsa, u holda $x \geq x_0$ da

$$|f(x) - f(x_0)| \leq j(x) - j(x_0)$$

tengsizlik o'rinli bo'lishini isbotlang.

Bu faktning geometrik interpretatsiyasini bering.

1285. $f(x)$ funksiya $a \leq x < +\infty$ oraliqda uzluksiz va bundan tashqari $x > a$ da

$$f'(x) > k > 0 \quad (k = \text{const})$$

bo'lsin. Agar $f(a) < 0$ bo'lsa, u holda $f(x) = 0$ tenglama $\left(a, a - \frac{f(a)}{k} \right)$ intervalda bitta va faqat bitta haqiqiy ildizga ega ekanligini isbotlang.

1286. Agar x_0 nuqtaning biror $|x - x_0| < d$ atrofida $\Delta f(x_0) = f(x) - f(x_0)$ funksiya orttiriasining ishorasi $\Delta x_0 = x - x_0$ argument orttiriasining ishorasi bilan ustma-ust tushsa, u holda $f(x)$ funksiya x_0 nuqtada o'suvchi deyiladi.

Agar $f(x)$ ($a < x < b$) funksiya biror chekli yoki cheksiz (a, b) intervalning har bir nuqtasida o'suvchi bo'lsa, u holda bu funksiya shu intervalda o'suvchi bo'lishini isbotlang.

1287. Ushbu

$$\Delta_s(a, b) = \left(\frac{a^3 + b^3}{2} \right)^{1/3}, \quad s \neq 0$$

va

$$\Delta_0(a, b) = \lim_{s \rightarrow 0} \Delta_s(a, b).$$

Xususan, $s = -1$ da o`rta garmonik; $s = 0$ da o`rta geometrik (isbotlang!); $s = 1$ da o`rta arifmetik; $s = 2$ da o`rta kvadratik qiymatlar hosil bo`ladi.

Quyidagilarni isbotlang:

- 1) $\min(a, b) \leq \Delta_s(a, b) \leq \max(a, b)$;
- 2) $\Delta_s(a, b)$ funksiya $a \neq b$ da s o`zgaruvchiga nisbatan o`svuchi;
- 3) $\lim_{s \rightarrow -\infty} \Delta_s(a, b) = \min(a, b)$; $\lim_{s \rightarrow +\infty} \Delta_s(a, b) = \max(a, b)$.

Yo`llanma. $\frac{d}{ds} [\ln \Delta_s(a, b)]$ hosilani ko`ring.

1297. Tengsizliklarni isbotlang:

- a) $x^a - 1 > a(x - 1)$, $a \geq 2$, $x > 1$;
- b) $\sqrt[n]{x} - \sqrt[n]{a} < \sqrt[n]{x - a}$, $n > 1$, $x > a > 0$;
- v) $1 + 2 \ln x \leq x^2$, $x > 0$.

8. Botiqlik yo`nalishi. egilish nuqtasi.

1298. Ushbu

$$y = 1 + \sqrt[3]{x}$$

egri chiziqning $A(-1, 0)$, $B(1, 2)$ va $C(0, 0)$ nuqtalardagi botiqlik yo`nalishini aniqlang.

Quyidagi funksiyalarning qavariqlik oraliqlarini va egilish nuqtalarini toping (1299-1307):

- | | |
|------------------------------|------------------------------------------------|
| 1299. $y = 3x^2 - x^3$. | 1300. $y = \frac{a^2}{a^2 + x^2}$ ($a > 0$). |
| 1301. $y = x + x^{5/3}$. | 1302. $y = \sqrt{1 + x^2}$. |
| 1303. $y = x + \sin x$. | 1304. $y = e^{-x^2}$. |
| 1305. $y = \ln(1 + x^2)$. | 1306. $y = x \sin(\ln x)$ ($x > 0$). |
| 1307. $y = x^x$ ($x > 0$). | |

1308. Ushbu

$$y = \frac{x+1}{x^2+1}$$

egri chiziq bir to`g`ri chiziqda yotuvchi uchta egilish nuqtasiga ega ekanligini isbotlang. Bu funksiya grafigini yasang.

1309. h parametrning qanday qiymatida ushbu

$$y = \frac{h}{\sqrt{p}} e^{-h^2 x^2} \quad (h > 0)$$

«ehtimollik chizig`i» $x = \pm s$ ga teng egilish nuqtalariga ega?

1310. TSikloidaning qavariqlik yo`nalishini aniqlang:

$$x = a(t - \sin t), \quad y = a(1 - \cos t) \quad (a > 0)$$

1311. $f(x)$ funksiya $a \leq x < +\infty$ oraliqda ikki marta differensiallanuvchi bo`lib, 1) $f(a) = A > 0$; 2) $f'(a) < 0$; 3) $x > a$ da $f''(x) \leq 0$ bo`lsin.

$f(x) = 0$ tenglama $(a, +\infty)$ intervalda bitta va faqat bitta haqiqiy ildizga ega ekanligini isbotlang.

1312. Agar (a, b) intervalda berilgan $f(x)$ funksiya uchun bu intervaldagi har qanday x_1 va x_2 nuqtalar hamda ixtiyoriy I_1 va I_2 sonlar uchun ($I_1 > 0, I_2 > 0, I_1 + I_2 = 1$) ushbu

$$f(I_1x_1 + I_2x_2) < I_1f(x_1) + I_2f(x_2) \quad (f(I_1x_1 + I_2x_2) > I_1f(x_1) + I_2f(x_2))$$

tengsizlik o`rinli bo`lsa, u holda $f(x)$ funksiya (a, b) intervalda quyidan (yuqoridan) qavariq deyiladi.

Quyidagilarni isbotlang:

1) Agar $a < x < b$ da $f''(x) > 0$ bo`lsa, $f(x)$ funksiya (a, b) da quyidan qavariq;

2) Agar $a < x < b$ da $f''(x) < 0$ bo`lsa, $f(x)$ funksiya (a, b) da yuqoridan qavariq bo`ladi.

1313. Ushbu

$$x^n (n > 1), \quad e^x, \quad x \ln x$$

funksiyalar $(0, +\infty)$ intervalda quyidan qavariq,

$$x^n (0 < n < 1), \quad \ln x$$

funksiyalar esa $(0, +\infty)$ intervalda yuqoridan qavariq ekanligini isbotlang.

1314. Quyidagi tengsizliklarni isbotlang va ularning geometrik ma`nosini aniqlang:

a) $\frac{1}{2}(x^n + y^n) > \left(\frac{x+y}{2}\right)^n$ ($x > 0, y > 0, x \neq y, n > 1$);

b) $\frac{e^x + e^y}{2} > e^{x+y/2}$ ($x \neq y$);

v) $x \ln x + y \ln y > (x+y) \ln \frac{x+y}{2}$, agar $x > 0, y > 0$.

1314.1. $a \leq x \leq b$ da $f''(x) \geq 0$ bo`lsin. Ixtiyoriy $x_1, x_2 \in [a, b]$ uchun

$$f\left(\frac{x_1 + x_2}{2}\right) \leq \frac{1}{2}[f(x_1) + f(x_2)]$$

tengsizlik o`rinli bo`lishini isbotlang.

1315. Chegaralangan qavariq funksiya $(-\infty, +\infty)$ da uzluksiz va bir tomonlama chap va o`ng hosilalarga ega ekanligini isbotlang.

1316. $f(x)$ funksiya (a, b) intervalda 2 marta differensiallanuvchi va $f''(x) \neq 0$ bo`lsin, bunda $a < x < b$. U holda (a, b) intervalda

$$\frac{f(x_2) - f(x_1)}{x_2 - x_1} = f'(x)$$

tenglik bajariladigan x_1 va x_2 nuqtalarni topish mumkinligini isbotlang.

1317. Agar $f(x)$ funksiya $(x_0, +\infty)$ cheksiz intervalda ikki marta differensiallanuvchi va

$$\lim_{x \rightarrow x_0+0} f(x) = 0, \quad \lim_{x \rightarrow +\infty} f(x) = 0$$

bo`lsa, u holda $(x_0, +\infty)$ intervalda $f''(x) = 0$ tenglik bajariladigan hech bo`lmaganda bitta x nuqta mavjudligini isbotlang.

9. Aniqmasliklarni ochish

Limitlarni hisoblang (1318-1370):

1318. $\lim_{x \rightarrow 0} \frac{\sin ax}{\sin bx}$.
1320. $\lim_{x \rightarrow 0} \frac{\operatorname{tg} x - x}{x - \sin x}$.
1322. $\lim_{x \rightarrow \frac{p}{2}} \frac{\operatorname{tg} 3x}{\operatorname{tg} x}$.
1324. $\lim_{x \rightarrow \frac{p}{4}} \frac{\sqrt[3]{\operatorname{tg} x} - 1}{2 \sin^2 x - 1}$.
1326. $\lim_{x \rightarrow 0} \frac{1 - \cos x^2}{x^2 \sin x^2}$.
1328. $\lim_{x \rightarrow 0} \frac{1}{x\sqrt{x}} \left(\sqrt{a} \operatorname{arctg} \sqrt{\frac{x}{a}} - \sqrt{b} \operatorname{arctg} \sqrt{\frac{x}{b}} \right)$.
1330. $\lim_{x \rightarrow 1} \left(\frac{x^x - x}{\ln x - x + 1} \right)$.
1332. $\lim_{x \rightarrow 0} \frac{\ln(\cos ax)}{\ln(\cos bx)}$.
1334. $\lim_{x \rightarrow 0} \frac{1}{x} \left(\frac{1}{\operatorname{th} x} - \frac{1}{\operatorname{tg} x} \right)$.
1336. $\lim_{x \rightarrow +\infty} \frac{\ln x}{x^e} \quad (e > 0)$.
1337. $\lim_{x \rightarrow +\infty} \frac{x^n}{e^{ax}} \quad (a > 0, n > 0)$.
1339. $\lim_{x \rightarrow +\infty} x^2 e^{-0,01x}$.
1341. $\lim_{x \rightarrow +0} x^e \ln x \quad (e > 0)$.
1343. $\lim_{x \rightarrow 0} x^{x^{x-1}}$.
1345. $\lim_{x \rightarrow +0} x^{k/(1+\ln x)}$.
1347. $\lim_{x \rightarrow 1} (2-x)^{\operatorname{tg} px/2}$.
1349. $\lim_{x \rightarrow 0} (\operatorname{ctg} x)^{\sin x}$.
1351. $\lim_{x \rightarrow \infty} \left(\operatorname{tg} \frac{px}{2x+1} \right)^{1/x}$.
1353. $\lim_{x \rightarrow 0} \left(\frac{a^x - x \ln a}{b^x - x \ln b} \right)^{1/x^2}$.
1355. $\lim_{x \rightarrow 1} \left(\frac{1}{\ln x} - \frac{1}{x-1} \right)$.
1319. $\lim_{x \rightarrow 0} \frac{\operatorname{ch} x - \cos x}{x^2}$.
1321. $\lim_{x \rightarrow 0} \frac{3 \operatorname{tg} 4x - 12 \operatorname{tg} x}{3 \sin 4x - 12 \sin x}$.
1323. $\lim_{x \rightarrow 0} \frac{x \operatorname{ctg} x - 1}{x^2}$.
1325. $\lim_{x \rightarrow 0} \frac{x(e^x + 1) - 2(e^x - 1)}{x^3}$.
1327. $\lim_{x \rightarrow 0} \frac{\arcsin 2x - 2 \arcsin x}{x^3}$.
1329. $\lim_{x \rightarrow 0} \frac{a^x - a^{\sin x}}{x^3} \quad (a > 0)$.
1331. $\lim_{x \rightarrow 0} \frac{\ln(\sin ax)}{\ln(\sin bx)}$.
1333. $\lim_{x \rightarrow 0} \frac{\cos(\sin x) - \cos x}{x^4}$.
1335. $\lim_{x \rightarrow 0} \frac{\operatorname{Arsh}(sh x) - \operatorname{Arsh}(\sin x)}{sh x - \sin x}$,
bunda $\operatorname{Arsh} x = \ln(x + \sqrt{1+x^2})$.
1338. $\lim_{x \rightarrow 0} \frac{e^{1/x^2}}{x^{100}}$.
1340. $\lim_{x \rightarrow 1-0} \ln x \cdot \ln(1-x)$.
1342. $\lim_{x \rightarrow +0} x^x$.
1344. $\lim_{x \rightarrow 0} (x^{x^x} - 1)$.
1346. $\lim_{x \rightarrow 1} x^{1/(1-x)}$.
1348. $\lim_{x \rightarrow \frac{p}{4}} (\operatorname{tg} x)^{\operatorname{tg} 2x}$.
1350. $\lim_{x \rightarrow +0} \left(\ln \frac{1}{x} \right)^x$.
1352. $\lim_{x \rightarrow a} \left(\frac{\operatorname{tg} x}{\operatorname{tg} a} \right)^{\operatorname{ctg}(x-a)}$.
1354. $\lim_{x \rightarrow 0} \left(\frac{1}{x} - \frac{1}{e^x - 1} \right)$.
1356. $\lim_{x \rightarrow 0} \left(\operatorname{ctg} x - \frac{1}{x} \right)$.

$$1357. \lim_{x \rightarrow 0} \left[\frac{1}{\ln(x + \sqrt{1+x^2})} - \frac{1}{\ln(1+x)} \right].$$

$$1358. \lim_{x \rightarrow a} \frac{a^x - x^a}{x - a} \quad (a > 0).$$

$$1359. \lim_{x \rightarrow 0} \frac{(1+x)^{1/x} - e}{x}.$$

$$1360. \lim_{x \rightarrow 0} \frac{(a+x)^x - a^x}{x^2} \quad (a > 0).$$

$$1361. \lim_{x \rightarrow +\infty} \left(\frac{2}{p} \operatorname{arctg} x \right)^x.$$

$$1362. \lim_{x \rightarrow +\infty} (th x)^x.$$

$$1363. \lim_{x \rightarrow 0} \left(\frac{\arcsin x}{x} \right)^{1/x^2}.$$

$$1361.1. \lim_{x \rightarrow 0} \left(\frac{\sin x}{x} \right)^{1/x^2}.$$

$$1363.2. \lim_{x \rightarrow 0} \left(\frac{tg x}{x} \right)^{1/x^2}.$$

$$1363.3. \lim_{x \rightarrow 0} \left(\frac{\operatorname{arctg} x}{x} \right)^{1/x^2}.$$

$$1363.4. \lim_{x \rightarrow 0} \left(\frac{\operatorname{Arsh} x}{x} \right)^{1/x^2}, \quad \operatorname{Arsh} x = \ln(x + \sqrt{1+x^2}).$$

$$1364. \lim_{x \rightarrow 0} \left[\frac{(1+x)^{1/x}}{e} \right]^{1/x}.$$

$$1365. \lim_{x \rightarrow 0} \left(\frac{2}{p} \arccos x \right)^{1/x}.$$

$$1366. \lim_{x \rightarrow 0} \left(\frac{\cos x}{ch x} \right)^{1/x^2}.$$

$$1367. \lim_{x \rightarrow 0} \frac{\ln ch x}{\sqrt[m]{ch x} - \sqrt[n]{ch x}}.$$

$$1368. \lim_{x \rightarrow 0} \left(\frac{1+e^x}{2} \right)^{ch x}.$$

$$1368.1. \lim_{x \rightarrow +\infty} \frac{x^{\ln x}}{(\ln x)^x}.$$

$$1369. \lim_{x \rightarrow +\infty} \left[\sqrt[3]{x^3 + x^2 + x + 1} - \sqrt{x^2 + x + 1} \cdot \frac{\ln(e^x + x)}{x} \right].$$

$$1370. \lim_{x \rightarrow +\infty} \left[(x+a)^{1+(1/x)} - x^{1+1/(x+a)} \right].$$

1371. Agar $y = f(x)$ egri chiziq $x \rightarrow 0$ da $(0, 0)$ ($\lim_{x \rightarrow 0} f(x) = f(0) = 0$) koordinata bo-shiga a burchak ostida kirs, $\lim_{x \rightarrow 0} \frac{y}{x}$ ni toping.

1372. Agar uzluksiz $y = f(x)$ egri chiziq $x \rightarrow +0$ da koordinata boshiga kirs ($\lim_{x \rightarrow +0} f(x) = 0$) va $0 < x < e$ da $y = -kx$ va $y = kx$ ($k \neq \infty$) to'g'ri chiziqlar tashkil qilgan o't-kir burchak ichida to'la yotsa, u holda $\lim_{x \rightarrow +0} x^{f(x)} = 1$ ni isbotlang.

1373. Agar $f(x)$ funksiya uchun 2-tartibli $f''(x)$ hosila mavjud bo'lsa, u holda quyidagini isbotlang:

$$f''(x) = \lim_{h \rightarrow 0} \frac{f(x+h) + f(x-h) - 2f(x)}{h^2}$$

1373.1. Quyidagi funktsiyani $x = 0$ nuqtada differensiallanuvchi bo'lishini tekshi-ring:

$$f(x) = \begin{cases} \frac{1}{x} - \frac{1}{e^x - 1}, & x \neq 0, \\ \frac{1}{2}, & x = 0. \end{cases}$$

1373.2. $y = \frac{x^{1+x}}{(1+x)^x}$ ($x > 0$) egri chiziqning asimptotasini toping.

1374. Quyidagi misollarga Lopital qoidasini tadbiiq qilish mumkin yoki mumkin emasligini aniqlang:

$$\begin{aligned} \text{a) } \lim_{x \rightarrow 0} \frac{x^2 \sin \frac{1}{x}}{\sin x}; & \quad \text{b) } \lim_{x \rightarrow \infty} \frac{x - \sin x}{x + \sin x}; & \quad \text{v) } \lim_{x \rightarrow +\infty} \frac{e^{-2x} (\cos x + 2 \sin x) + e^{-x^2} \sin^2 x}{e^{-x} (\cos x + \sin x)}; \\ \text{g) } \lim_{x \rightarrow \infty} \frac{1 + x + \sin x \cos x}{(x + \sin x \cos x) e^{\sin x}}. & \end{aligned}$$

1375. Agar b vatarga va h strelkaga ega doiraviy segment yoyining uzunligi R radius o'zgaragan holda nolga intilsa, u holda bu doiraviy segment yuzining shu segmentga ichki chizilgan teng yonli uchburchakning yuziga nisbatini toping. Olingan natijadan foydalanib, segment yuzi uchun taqribiy formulani keltirib chiqaring:

$$S \approx \frac{2}{3}bh.$$

10. Teylor formulasi

1376. Ushbu

$$P(x) = 1 + 3x + 5x^2 - 2x^3$$

ko'phadni $x+1$ ikkihadning butun nomanfiy darajalari bo'yicha yoying.

Quyidagi funksiyalarni x o'zgaruvchining butun nomanfiy darajalari bo'yicha ko'rsatilgan tartibli hadlarigacha yoying (1377-1387):

1377. $f(x) = \frac{1+x+x^2}{1-x+x^2}$, x^4 hadigacha. $f^{(4)}(0)$ ning qiymati nimaga teng?

1378. $\frac{(1+x)^{100}}{(1-2x)^{40}(1+2x)^{60}}$, x^2 hadigacha.

1379. $\sqrt[m]{a^m+x}$ ($a > 0$), x^2 hadigacha.

1380. $\sqrt{1-2x+x^3} - \sqrt[3]{1-3x+x^2}$, x^3 hadigacha.

1381. e^{2x-x^2} , x^5 hadigacha.

1382. $x(e^x-1)^{-1}$, x^4 hadigacha.

1383. $\sqrt[3]{\sin x^3}$, x^{13} hadigacha.

1384. $\ln \cos x$, x^6 hadigacha.

1385. $\sin(\sin x)$, x^3 hadigacha.

1386. $\operatorname{tg} x$, x^5 hadigacha.

1387. $\ln \frac{\sin x}{x}$, x^6 hadigacha.

1388. $f(x) = \sqrt{x}$ funksiyaning $(x-1)$ ning butun nomanfiy darajalari bo'yicha yoyilmasining uchta hadini toping.

1389. $f(x) = x^x - 1$ funksiyani $(x-1)$ ning butun nomanfiy darajalari bo'yicha $(x-1)^3$ hadigacha yoying.

1390. $y = a \operatorname{ch} \frac{x}{a}$ ($a > 0$) funksiyani $x=0$ nuqta atrofida ikkinchi tartibli parabola bilan taqribiy almashtiring.

1391. $f(x) = \sqrt{1+x^2} - x$ ($x > 0$) funksiyani $\frac{1}{x}$ kasrning butun musbat darajalari bo'yicha

$\frac{1}{x^3}$ hadigacha yoying.

1392. $f(h) = \ln(x+h)$ ($x > 0$) funksiyani h orttirmaning butun nomanfiy daraja-lari bo'yicha h^n hadigacha yoying ($n \in N$).

1393. Ushbu

$$f(x+h) = f(x) + hf'(x) + \dots + \frac{h^n}{n!} f^{(n)}(x+qh)$$

yoyilmada ($0 < q < 1$) $f^{(n+1)}(x) \neq 0$ bo'lsin.

Isbotlang: $\lim_{n \rightarrow 0} q = \frac{1}{n+1}$.

1393.1. $x \rightarrow 0$ da

$$f(x) = 1 + kx + o(x)$$

bo'lsin. Isbotlang: $\lim_{x \rightarrow 0} [f(x)]^{1/x} = e^k$

1393.2. $f(x) \in C^{(2)}[0, 1]$ va $f(0) = f(1) = 0$ bo'lsin hamda $x \in (0, 1)$ da $|f''(x)| \leq A$ tengsizlik bajarilsin. U holda $0 \leq x \leq 1$ da

$$|f'(x)| \leq \frac{A}{2}$$

tengsizlik o'rinli bo'lishini isbotlang.

1393.3. $f(x)$ ($-\infty < x < +\infty$) - ikki marta differensiallanuvchi funksiya bo'lsin va

$$M_k = \sup_{-\infty < x < +\infty} |f^{(k)}(x)| < +\infty \quad (k = 0, 1, 2).$$

Tengsizlikni isbotlang: $M_1^2 \leq 2M_0M_2$

1394. Taqribiy formulalarning absolyut xatoligini baholang:

a) $e^x \approx 1 + x + \frac{x^2}{2!} + \dots + \frac{x^n}{n!}$, $0 \leq x \leq 1$; b) $\sin x \approx x - \frac{x^3}{6}$, $|x| \leq \frac{1}{2}$;

v) $\operatorname{tg} x \approx x + \frac{x^3}{3}$, $|x| \leq 0,1$; g) $\sqrt{1+x} \approx 1 + \frac{x}{2} - \frac{x^2}{8}$, $0 \leq x \leq 1$.

1395. Quyidagi taqribiy formula qanday x lar uchun 0,0001 aniqlikda o'rinli:

$$\cos x = 1 - \frac{x^2}{2} ?$$

1395.1. Formulani isbotlang:

$$\sqrt[n]{a^n + x} = a + \frac{x}{na^{n-1}} - r \quad (n \geq 2, a > 0, x > 0), \quad 0 < r < \frac{n-1}{2n^2} \cdot \frac{x^2}{a^{2n-1}}.$$

1396. Teylor formulasidan foydalanib taqribiy hisoblang:

a) $\sqrt[3]{30}$; b) $\sqrt[5]{250}$; v) $\sqrt[12]{4000}$; g) \sqrt{e} ; d) $\sin 18^\circ$;
e) $\ln 1,2$; j) $\operatorname{arctg} 0,8$; z) $\arcsin 0,45$; i) $(1,1)^{1,2}$

va xatolikni baholang.

1397. Hisoblang:

a) e , 10^{-9} aniqlikda; b) $\sin 1^\circ$, 10^{-8} aniqlikda; v) $\cos 9^\circ$, 10^{-5} aniqlikda; g) $\sqrt{5}$, 10^{-4} aniqlikda; d) $\lg 11$, 10^{-5} aniqlikda.

I-V yoyilmalardan foydalanib, quyidagi limitlarni toping (1398-1406.3):

1398. $\lim_{x \rightarrow 0} \frac{\cos x - e^{-x^2/2}}{x^4}$.

1399. $\lim_{x \rightarrow 0} \frac{e^x \sin x - x(1+x)}{x^3}$.

1400. $\lim_{x \rightarrow +\infty} x^{3/2} (\sqrt{x+1} + \sqrt{x-1} - 2\sqrt{x})$.

1401. $\lim_{x \rightarrow +\infty} (\sqrt[6]{x^6 + x^5} - \sqrt[6]{x^6 - x^5})$.

$$1402. \lim_{x \rightarrow +\infty} \left[\left(x^3 - x^2 + \frac{x}{2} \right) e^{1/x} - \sqrt{x^6 + 1} \right].$$

$$1403. \lim_{x \rightarrow 0} \frac{a^x + a^{-x} - 2}{x^2} \quad (a > 0).$$

$$1404. \lim_{x \rightarrow \infty} \left[x - x^2 \ln \left(1 + \frac{1}{x} \right) \right].$$

$$1405. \lim_{x \rightarrow 0} \left(\frac{1}{x} - \frac{1}{\sin x} \right).$$

$$1406. \lim_{x \rightarrow 0} \frac{1}{x} \left(\frac{1}{x} - \operatorname{ctg} x \right).$$

$$1406.1. \lim_{x \rightarrow 0} \frac{\sin(\sin x) - x \sqrt[3]{1-x^2}}{x^5}.$$

$$1406.2. \lim_{x \rightarrow 0} \frac{1 - (\cos x)^{\sin x}}{x^3}.$$

$$1406.3. \lim_{x \rightarrow 0} \frac{\operatorname{sh}(tg x) - x}{x^3}.$$

Quyidagi misollarda $x \rightarrow 0$ da cheksiz kichik miqdor y uchun Cx^n ($C = \text{const}$) ko`rinishdagi bosh hadini aniqlang (1407-1409):

$$1407. y = \operatorname{tg}(\sin x) - \sin(\operatorname{tg} x).$$

$$1408. y = (1+x)^x - 1.$$

$$1409. y = 1 - \frac{(1+x)^{1/x}}{e}.$$

1410. a va b koeffitsientlarning qanday qiymatlarida

$$x - (a + b \cos x) \sin x$$

kattalik x ga nisbatan 5-tartibli cheksiz kichik miqdor bo`ladi?

1410.1. A va B koeffitsientlarni shunday tanlangki, $x \rightarrow 0$ da ushbu

$$\operatorname{ctg} x = \frac{1 + Ax^2}{x + Bx^3} + O(x^5)$$

asimptotik tenglik o`rinli bo`lsin.

1410.2. A, B, C va D koeffitsientlarning qanday qiymatlarida $x \rightarrow 0$ da ushbu

$$e^x = \frac{1 + Ax + Bx^2}{1 + Cx + Dx^2} + O(x^5)$$

asimptotik formula o`rinli bo`ladi?

1411. $|x|$ ni cheksiz kichik deb, quyidagi funksiyalar uchun oddiy taqribiy formulalarni keltirib chiqaring:

$$\text{a) } \frac{1}{R^2} - \frac{1}{(R+x)^2} \quad (R > 0); \quad \text{b) } \sqrt[3]{\frac{1+x}{1-x}} - \sqrt[3]{\frac{1-x}{1+x}}; \quad \text{v) } \frac{A}{x} \left[1 - \left(1 + \frac{x}{100} \right)^{-n} \right]; \quad \text{g) } \frac{\ln 2}{\ln \left(1 + \frac{x}{101} \right)}.$$

1412. $|x|$ ni cheksiz kichik deb, $x = a \sin x + b \operatorname{tg} x$ ko`rinishdagi taqribiy formulani x^5 hadigacha aniqlikda keltirib chiqaring.

Bu formulani cheksiz kichik burchak kattaligi yoylarini taqribiy to`g`rilash uchun qo`llang.

1413. Quyidagi CHEbishev qoidasining nisbiy xatoligini baholang: doiraviy yoy taqriban shu yoy vatariga qurilgan va balandligi $\sqrt{4/3}$ ga teng segment balanligiga (strelkasiga) teng bo`lgan teng yonli uchburchakning yon tomonlari yig`indisiga teng.

11. Funksiya ekstremumi. Funksiyaning eng katta va eng kichik qiymatlari

Quyidagi funksiyalarni ekstremumga tekshiring (1414-1422):

1414. $y = 2 + x - x^2$. 1415. $y = (x-1)^3$. 1416. $y = (x-1)^4$.
 1417. $y = x^m (1-x)^n$ ($m \in \mathbb{Z}, n \in \mathbb{Z}, m > 0, n > 0$). 1418. $y = \cos x + \operatorname{ch} x$.
 1419. $y = (x+1)^{10} e^{-x}$. 1420. $y = \left(1 + x + \frac{x^2}{2!} + \dots + \frac{x^n}{n!}\right) e^{-x}$ ($n \in \mathbb{N}$).
 1421. $y = |x|$. 1422. $y = x^{1/3} (1-x)^{2/3}$.
 1423. Ushbu

$$f(x) = (x - x_0)^n j(x) \quad (n \in \mathbb{N})$$

funksiyani $x = x_0$ nuqtada ekstremumga tekshiring, bunda $j(x)$ funksiya $x = x_0$ nuqtada uzluksiz va $j(x_0) \neq 0$.

1424. $f(x) = \frac{P(x)}{Q(x)}$, $f'(x) = \frac{P_1(x)}{Q^2(x)}$ va x_0 - $f(x)$ funksiyaning statsionar nuqtasi bo'lsin,

ya'ni $P_1(x_0) = 0$, $Q(x_0) \neq 0$. U holda quyidagi tenglikni isbotlang:

$$\operatorname{sgn} f''(x_0) = \operatorname{sgn} P_1'(x_0).$$

1425. Agar $f(x)$ funksiya x_0 nuqtada maksimumga ega bo'lsa, u holda $f(x)$ funksiya bu nuqtaning biror etarlicha kichik atrofida x_0 nuqtadan chapda o'suvchi va x_0 nuqtadan o'ngda esa kamayuvchi bo'ladi. SHu tasdiq o'rinlimi?

Quyidagi misolni ko'ring:

Agar $x \neq 0$ bo'lsa, $f(x) = 2 - x^2 \left(2 + \sin \frac{1}{x}\right)$ va $f(0) = 2$.

1426. Isbotlang: $x \neq 0$ da $f(x) = e^{-1/x^2}$ va $f(0) = 0$ bo'lgan funksiya $x = 0$ nuqtada minimumga ega, $x \neq 0$ da $g(x) = xe^{-1/x^4}$ va $g(0) = 0$ funksiya esa $x = 0$ nuqtada ekstremumga ega emas, vaholanki,

$$f^{(n)}(0) = 0, \quad g^{(n)}(0) = 0 \quad (n = 1, 2, \dots).$$

Bu funksiyalarning grafigini yasang.

1427. Quyidagi funksiyalarni ekstremumga tekshiring:

a) $x \neq 0$ da $f(x) = e^{-1/|x|} \left(\sqrt{2} + \sin \frac{1}{x}\right)$ va $f(0) = 0$;

b) $x \neq 0$ da $f(x) = e^{-1/|x|} \left(\sqrt{2} + \cos \frac{1}{x}\right)$ va $f(0) = 0$.

Bu funksiyalarning grafigini yasang.

1428. Ushbu

$$x \neq 0 \text{ da } f(x) = |x| \left(2 + \cos \frac{1}{x}\right) \text{ va } f(0) = 0$$

funksiyani $x = 0$ nuqtada ekstremumga tekshiring.

Bu funksiyaning grafigini yasang.

Quyidagi funksiyalarning ekstremumlarini toping (1429-1444):

1429. $y = x^3 - 6x^2 + 9x - 4$. 1430. $y = 2x^2 - x^4$.

1431. $y = x(x-1)^2(x-2)^3$. 1432. $y = x + \frac{1}{x}$.

1433. $y = \frac{2x}{1+x^2}$. 1434. $y = \frac{x^2 - 3x + 2}{x^2 + 2x + 1}$.

$$1435. y = \sqrt{2x - x^2}.$$

$$1437. y = xe^{-x}.$$

$$1439. y = \frac{\ln^2 x}{x}.$$

$$1441. y = \frac{10}{1 + \sin^2 x}.$$

$$1443. y = e^x \sin x.$$

$$1436. y = x\sqrt[3]{x-1}.$$

$$1438. y = \sqrt{x} \ln x.$$

$$1440. y = \cos x + \frac{1}{2} \cos 2x.$$

$$1442. y = \operatorname{arctg} x - \frac{1}{2} \ln(1 + x^2).$$

$$1444. y = |x|e^{-|x-1|}$$

Quyidagi funksiyalarning ko'rsatilgan kesmalarda eng katta va eng kichik qiymatlarini toping (1445-1449):

$$1445. f(x) = 2^x, [-1; 5].$$

$$1446. f(x) = x^2 - 4x + 6, [-3; 10].$$

$$1447. f(x) = |x^2 - 3x + 2|, [-10; 10].$$

$$1448. f(x) = x + \frac{1}{x}, [0,01; 100].$$

$$1449. f(x) = \sqrt{5-4x}, [-1; 1].$$

Quyidagi funksiyalarning ko'rsatilgan oraliqlarda aniq quyi (inf) va aniq yuqori chegaralarini (sup) toping (1450-1453):

$$1450. f(x) = xe^{-0,01x}, (0, +\infty). \quad 1451. f(x) = \left(1 + x + \frac{x^2}{2!} + \dots + \frac{x^n}{n!}\right)e^{-x}, (0, +\infty).$$

$$1452. f(x) = \frac{1+x^2}{1+x^4}, (0, +\infty). \quad 1453. f(x) = e^{-x^2} \cos x^2, (-\infty, +\infty).$$

1454. $x < x < +\infty$ intervalda ushbu

$$f(x) = \frac{1+x}{3+x^2}$$

funksiyaning aniq quyi (inf) va aniq yuqori chegaralarini (sup) toping va

$$M(x) = \sup_{x < x < +\infty} f(x), \quad m(x) = \inf_{x < x < +\infty} f(x)$$

funksiyalarning grafiklarini yasang.

$$1454.1. M_k = \sup_x \|f^{(k)}(x)\|, \quad k = 0, 1, 2, \dots \text{ bo'lsin. Agar } f(x) = e^{-x^2} \text{ bo'lsa, } M_0, M_1 \text{ va}$$

M_2 larni toping.

1455. Ketma-ketlikning eng katta hadini toping:

$$a) \frac{n^{10}}{2^n} \quad (n = 1, 2, \dots); \quad b) \frac{\sqrt{n}}{n+10000} \quad (n = 1, 2, \dots); \quad v) \sqrt[n]{n} \quad (n = 1, 2, \dots).$$

1456. Tengsizliklarni isbotlang:

$$a) |3x - x^3| \leq 2, |x| \leq 2;$$

$$b) \frac{1}{2^{p-1}} \leq x^p + (1-x)^p \leq 1, \text{ agar } 0 \leq x \leq 1 \text{ va } p > 1 \text{ bo'lsa};$$

$$v) x^m (a-x)^n \leq \frac{m^n n^n}{(m+n)^{m+n}} a^{m+n}, \quad m > 0, n > 0 \text{ va } 0 \leq x \leq a;$$

$$g) \frac{x+a}{2^{(n-1)/n}} \leq \sqrt[n]{x^n + a^n} \leq x+a \quad (x > 0, a > 0, n > 1);$$

$$d) |a \sin x + b \cos x| \leq \sqrt{a^2 + b^2}.$$

1456.1. Tengsizlikni isbotlang:

$$\frac{2}{3} \leq \frac{x^2 + 1}{x^2 + x + 1} \leq 2, \quad -\infty < x < +\infty$$

1457. $P(x) = x(x-1)^2(x+2)$ ko'phadning $[-2, 1]$ kesmada "noldan farqini" aniqlang, ya'ni

$$E_p = \sup_{-2 \leq x \leq 1} |P(x)|$$

ni toping.

1458. q koeffitsientning qanday qiymatida $P(x) = x^2 + q$ ko'phad $[-1, 1]$ kesmada noldan eng kam farq qiladi, ya'ni

$$E_p = \sup_{-1 \leq x \leq 1} |P(x)| = \min$$

bo'ladi.

1459. Ikki $f(x)$ va $g(x)$ funksiyalarning $[a, b]$ kesmada absolyut farqi deb ushbu

$$\Delta = \sup_{a \leq x \leq b} |f(x) - g(x)|$$

songa aytiladi. Quyidagi funksiyalarning $[0, 1]$ kesmada absolyut farqini aniqlang:

$$f(x) = x^2 \text{ va } g(x) = x^3.$$

1460. $f(x) = x^2$ funksiyani $[x_1, x_2]$ kesmada ushbu

$$g(x) = (x_1 + x_2)x + b$$

chiziqli funksiya bilan shunday taqribiy almashtiringki, $f(x)$ va $g(x)$ funksiyalarning absolyut farqi eng kichik bo'lsin va bu absolyut farqni aniqlang.

1461. Quyidagi funksiyaning minimumini aniqlang:

$$f(x) = \max\{2|x|, |1+x|\}.$$

Quyidagi tenglamalarning haqiqiy ildizlari sonini aniqlang va bu ildizlarni ajrating (1462-1469):

$$1462. x^3 - 6x^2 + 9x - 10 = 0.$$

$$1463. x^3 - 3x^2 - 9x + h = 0.$$

$$1464. 3x^4 - 4x^3 - 6x^2 + 12x - 20 = 0.$$

$$1465. x^5 - 5x = a.$$

$$1466. \ln x = kx.$$

$$1467. e = ax^2.$$

$$1468. \sin^3 x \cdot \cos x = a, 0 \leq x \leq p.$$

$$1469. \operatorname{ch} x = kx.$$

1470. Qanday shart bajarilganda ushbu

$$x^3 + px + q = 0$$

tenglama a) bitta haqiqiy ildizga ega; b) uchta haqiqiy ildizga ega? (p, q) tekislikda mos sohalarni tasvirlang.

12. Funksiya grafigini yasash

Quyidagi funksiyalarning grafigini yasang (1471-1530):

$$1471. y = 3x - x^3.$$

$$1472. y = 1 + x^2 - \frac{x^4}{2}.$$

$$1473. y = (x+1)(x-2)^2.$$

$$1474. y = \frac{2-x^2}{1+x^4}.$$

$$1475. y = \frac{x^2 - 1}{x^2 - 5x + 6}.$$

$$1476. y = \frac{x}{(1+x)(1-x)^2}.$$

$$1477. y = \frac{x^4}{(1+x)^3}.$$

$$1478. y = \left(\frac{1+x}{1-x}\right)^4.$$

1479. $y = \frac{x^2(x-1)}{(x+1)^2}$.
1481. $y = \frac{(x+1)^3}{(x-1)^2}$.
1483. $y = \frac{1}{1+x} - \frac{10}{3x^2} + \frac{1}{1-x}$.
1485. $y = \pm\sqrt{8x^2 - x^4}$.
1486. $y = \pm\sqrt{(x-1)(x-2)(x-3)}$.
1488. $y = \sqrt[3]{x^2} - \sqrt[3]{x^2+1}$.
1490. $y = (x+1)^{2/3} + (x-1)^{2/3}$.
1492. $y = \frac{x^2\sqrt{x^2-1}}{2x^2-1}$.
1494. $y = 1-x + \sqrt{\frac{x^3}{3+x}}$.
1496. $y = \sqrt{\frac{x^4+3}{x^2+1}}$.
1498. $y = (7+2\cos x)\sin x$.
1500. $y = \cos x - \frac{1}{2}\cos 2x$.
1502. $y = \sin x \cdot \sin 3x$.
1504. $y = \frac{\cos x}{\cos 2x}$.
1505. $y = 2x - \operatorname{tg} x$.
1507. $y = (1+x^2)e^{-x^2}$.
1509. $y = x^{2/3}e^{-x}$.
1510. $y = \frac{e^x}{1+x}$.
1512. $y = \frac{\ln x}{\sqrt{x}}$.
1514. $y = \sqrt{x^2+1} \cdot \ln(x + \sqrt{x^2+1})$.
1516. $y = x + \operatorname{arctg} x$.
1518. $y = x \operatorname{arctg} x$.
1480. $y = \frac{x}{(1-x^2)^2}$.
1482. $y = \frac{x^4+8}{x^3+1}$.
1484. $y = (x-3)\sqrt{x}$.
- 1485.1. $y = \frac{x-2}{\sqrt{x^2+1}}$.
1487. $y = \sqrt[3]{x^3-x^2-x+1}$.
1489. $y = (x+2)^{2/3} - (x-2)^{2/3}$.
1491. $y = \frac{x}{\sqrt[3]{x^2-1}}$.
1493. $y = \frac{|1+x|^{3/2}}{\sqrt{x}}$.
1495. $y = \sqrt[3]{\frac{x^2}{x+1}}$.
1497. $y = \sin x + \cos^2 x$.
1499. $y = \sin x + \frac{1}{3}\sin 3x$.
1501. $y = \sin^4 x + \cos^4 x$.
1503. $y = \frac{\sin x}{\sin\left(x + \frac{p}{4}\right)}$.
- 1504.1. $y = \frac{\sin x}{2 + \cos x}$.
1506. $y = e^{2x-x^2}$.
1508. $y = x + e^{-x}$.
- 1509.1. $y = e^{-2x} \sin^2 x$.
1511. $y = \sqrt{1-e^{-x^2}}$.
1513. $y = \ln(x + \sqrt{x^2+1})$.
1515. $y = \frac{\arcsin x}{\sqrt{1-x^2}}$.
1517. $y = \frac{x}{2} + \operatorname{arctg} x$.
1519. $y = \arcsin \frac{2x}{1+x^2}$.

$$1520. y = \arccos \frac{1-x^2}{1+x^2}.$$

$$1522. y = 2\sqrt{x^2+1}-\sqrt{x^2-1}.$$

$$1524. y = a \arcsin \frac{x}{a} - \sqrt{a^2 - x^2} \quad (a > 0).$$

$$1526. y = x^x.$$

$$1528. y = (1+x)^{\frac{1}{x}}.$$

$$1530. y = \frac{e^{\frac{1}{1-x^2}}}{1+x^2} \quad (\text{qavariqligini aniqlamasdan}).$$

Quyidagi parametrik ko`rinishda berilgan egri chiziqlarni yasang (1531-1540):

$$1531. x = \frac{(t+1)^2}{4}, \quad y = \frac{(t-1)^2}{4}.$$

$$1533. x = \frac{t^2}{t-1}, \quad y = \frac{t}{t^2-1}.$$

$$1535. x = t + e^{-t}, \quad y = 2t + e^{-2t}.$$

$$1537. x = \cos^4 t, \quad y = \sin^4 t.$$

$$1539. x = \frac{a}{\cos^3 t}, \quad y = atg^3 t \quad (a > 0).$$

$$1540. x = a(\text{sh}t - t), \quad y = a(\text{ch}t - 1) \quad (a > 0).$$

Quyidagi egri chiziqlarning tenglamalarini parametrik ko`rinishga keltirib, egri chiziqlarni yasang (1541-1544):

$$1541. x^3 + y^3 - 3axy = 0 \quad (a > 0).$$

$$1542. x^2 + y^2 = x^4 + y^4.$$

$$1544. x^y = y^x \quad (x > 0, y > 0).$$

$$1545. \text{egri chiziqning grafigini yasang: } ch^2 x - ch^2 y = 1.$$

Quyidagi (j, r) ($r \geq 0$) qutb koordinatalar sistemasida berilgan funksiyalarning grafigini yasang (1546-1550):

$$1546. r = a + b \cos j \quad (0 < a \leq b).$$

$$1548. r = \frac{a}{\sqrt{\cos 3j}} \quad (a > 0).$$

$$1550. j = \arccos \frac{r-1}{r^2}.$$

Quyidagi egri chiziqlar oilasining grafigini yasang (a - o`zgaruvchi parametr, 1551-1555):

$$1551. y = x^2 - 2x + a.$$

$$1553. y = x \pm \sqrt{a(1-x^2)}.$$

$$1555. y = xe^{\frac{x}{a}}.$$

$$1521. y = (x+2)e^{\frac{1}{x}}.$$

$$1523. y = \ln \frac{x^2 - 3x + 2}{x^2 + 1}.$$

$$1525. y = \arccos \frac{1-x}{1-2x}.$$

$$1527. y = x^{\frac{1}{x}}.$$

$$1529. y = x \left(1 + \frac{1}{x}\right)^x \quad (x > 0).$$

$$1532. x = 2t - t^2, \quad y = 3t - t^3.$$

$$1534. x = \frac{t^2}{1-t^2}, \quad y = \frac{1}{1+t^2}.$$

$$1536. x = a \cos 2t, \quad y = a \cos 3t \quad (a > 0).$$

$$1538. x = t \ln t, \quad y = \frac{\ln t}{t}.$$

Y o`l l a n m a. $y = tx$ deb oling.

$$1543. x^2 y^2 = x^3 - y^3.$$

$$1547. r = a \sin 3j \quad (a > 0).$$

$$1549. r = a \frac{thj}{j-1}, \quad j > 1 \quad (a > 0).$$

$$1552. y = x + \frac{a^2}{x}.$$

$$1554. y = \frac{x}{2} + e^{-ax}.$$

13. Funksiyaning maksimum va minimumiga doir masalalar

1556. Agar $f(x)$ funksiya nomanfiy bo'lsa, u holda

$$F(x) = Cf^2(x) \quad (C > 0)$$

funksiya $f(x)$ funksiya bilan bir xil ekstremumlarga ega ekanligini isbotlang.

1557. Agar $j(x)$ funksiya $-\infty < x < +\infty$ oraliqda qat'iy monoton o'suvchi bo'lsa, u holda $f(x)$ va $j(f(x))$ funksiyalar bir xil ekstremumga ega ekanligini isbotlang.

1558. Yig'indisi o'zgarmas a songa teng bo'lgan ikki musbat sonlarning m -chi va n -chi darajalari ($m > 0$, $n > 0$) ko'paytmasining eng katta qiymatini toping.

1559. Ko'paytmasi o'zgarmas a songa teng bo'lgan ikki musbat sonlarning m -chi va n -chi darajalari ($m > 0$, $n > 0$) yig'indisining eng kichik qiymatini toping.

1560. Qanday logarifmlar sistemasida o'zining logarifmiga teng bo'lgan sonlar mavjud?

1561. Berilgan S yuzali barcha to'g'ri to'rtburchaklar ichidan perimetri eng kichik bo'lganini aniqlang.

1562. Kateti bilan gipotenuzasi yig'indisi o'zgarmas songa teng bo'lgan eng katta yuzali to'g'ri burchakli uchburchakni toping.

1563. CHiziqli o'lchovlarining qanday qiymatlarida V hajmli yopiq tsilindrik banka eng kichik to'la sirtga ega bo'ladi?

1564. YArim doiradan katta bo'lmagan doiraviy segment ichiga eng katta yuzali to'g'ri to'rtburchak chizing.

1565. Ushbu

$$\frac{x^2}{a^2} + \frac{y^2}{b^2} = 1$$

ellipsga tomonlari ellips o'qlariga parallel bo'lgan eng katta yuzali to'g'ri to'rtburchak chizing.

1566. b asosga va h balandlikka ega bo'lgan uchburchakka eng katta perimetrli to'g'ri to'rtburchak chizing.

Bu masalani echish imkoniyatlarini o'rganing.

1567. d diametrli doiraviy g'oladan asosi b va balandligi h bo'lgan to'g'ri to'rtburchakli to'sin o'yilyapti. Agar to'sinning chidamliligi bh^2 ga proporsional bo'lsa, qanday o'lchamlarda to'sinning chidamliligi eng katta bo'ladi?

1568. R radiusli yarim shar ichiga asosi kvadrat bo'lgan eng katta hajmli parallelepiped chizing.

1569. R radiusli sharga eng katta hajmli ichki tsilindr chizing.

1570. R radiusli sharga to'la sirti eng katta bo'lgan ichki tsilindr chizing.

1571. Berilgan sharga eng kichik hajmli tashqi konus chizing.

1572. YAsovchisi l bo'lgan konusning eng katta hajmini toping.

1573. Asosining radiusi R va o'q kesimining burchagi 2α bo'lgan to'g'ri doiraviy konusga eng katta to'la sirtga ega ichki tsilindr chizing.

1574. $y^2 = 2px$ paraboladan $M(p, p)$ nuqttagacha bo'lgan eng qisqa masofani toping.

1575. $x^2 + y^2 = 1$ aylanadan $A(2, 0)$ nuqttagacha bo'lgan eng qisqa va eng katta masofani toping.

1576. $\frac{x^2}{a^2} + \frac{y^2}{b^2} = 1$ ($0 < b < a$) ellipsning $B(0, -b)$ uchidan o'tuvchi eng katta vatarini toping.

1577. $\frac{x^2}{a^2} + \frac{y^2}{b^2} = 1$ ellipsdagi $M(x, y)$ nuqta orqali koordinata o'qlari bilan eng kichik

yuzali uchburchak hosil qiluvchi urinma o'tkazing.

1578. Jism yuqoridan yarim shar bilan tugallangan to'g'ri doiraviy tsilindrdan iborat. Agar uning hajmi V bo'lsa, chiziqli o'lchamlarning qanday qiymatlarida bu jism eng kichik to'la sirtga ega bo'ladi?

1579. Ochiq kanalning ko'ndalang kesimi teng yonli trapetsiya shakliga ega. Agar kanaldagi suvning "tirik kesimining" yuzasi S , suvning sathi esa h bo'lsa, kesimning "nam perimetri" eng kichik bo'lishi uchun yon tomonlarni qanday j burchakka og'dirish kerak? 1580. S yuzali yopiq konturning egri-bugriligi deb bu kontur perimetrini S yuzali doira aylanasi uzunligiga nisbatiga aytiladi.

Agar eng kichik egri-bugrilikka ega $ABCD$ ($AD \parallel BC$) teng yonli trapetsiyaning asosi $AD = 2a$ va o'tkir burchagi $\angle BAD = \alpha$ ga teng bo'lsa, bu trapetsiya qanday shaklga ega?

1581. R radiusli doiradan sektor qirqib olingandan so'ng qolgan qismidan eng katta hajmli voronka o'rash uchun undan qanday sektor qirqib olish kerak?

1582. A zavod janubdan shimolga qarab yuruvchi va B shahardan o'tuvchi temir yo'ldan eng qisqa a km masofada joylashgan. Bir tonna yukni 1 km masofaga shoxobcha yo'lda tashish p so'm, temir yo'lda tashish esa q so'mni ($p > q$) tashkil qilishini hamda B shahar A shahardan b km shimolda joylashganligini e'tiborga olib, A dan B ga yuk tashish eng tejamli bo'lishi uchun zavoddan chiquvchi shoxobcha yo'lni temir yo'lga qanday j burchak ostida qurish kerak?

1583. O'zgarmas u va u tezliklarga ega bo'lgan ikkita kemalar oralaridagi burchak α bo'lgan ikkita to'g'ri chiziq bo'ylab suzmoqda. Agar ma'lum vaqtdan keyin kemalar bilan ularning yo'llari kesishgan nuqtagacha bo'lgan masofalar mos ravishda a va b ga teng bo'lsa, u holda kemalar orasidagi eng qisqa masofani toping.

1584. A va B nuqtalarda mos ravishda S_1 va S_2 sham kuchiga ega bo'lgan yorug'lik manbalari joylashgan. $AB = a$ kesmadagi eng kam yorug'lik tushayotgan M nuqtani toping.

1585. R va r ($R > r$) radiusli ikkita kesishmaydigan sharlar markazlarining to'g'ri chizig'ida hamda sharlardan tashqarida yorituvchi nuqta joylashgan. Nuqtaning qanday joylashishida sharlar sirtlarining yoritilgan qismlari yig'indisi eng katta bo'ladi?

1586. a radiusli doiraviy stol qirg'og'ining yorug'lik tushgan qismi eng katta bo'lishi uchun stoldan qanday balandlikda elektr lampa o'rnatish kerak?

Y o' l l a n m a. Yorug'lik ravshanligi $I = k \frac{\sin j}{r^2}$ formula orqali ifodalanadi, bunda j – nurlarning og'ish burchagi, r – yoritilayotgan yuzadan yorug'lik manbaigacha masofa, k – yorug'lik manbaining kuchi.

1587. a m kenglikdagi daryoga to'g'ri burchak ostida b m kenglikdagi kanal qurilgan. Qanday eng katta uzunlikdagi kemalar bu kanalga kirishi mumkin?

1588. Kemaning suzishiga sarflanadigan bir sutkalik xarajatlar ikki qismdan iborat: a so'mdan iborat o'zgarmas qismi va tezlikning kubiga proporsional o'suvchi o'zgaruvchi qism. v tezlik qanday bo'lganda kemaning suzishi eng tejamli bo'ladi?

1589. Gorizonttal notekis (g'adir-budir) tekislikda yotgan P og'irlikdagi yukni unga qo'yilgan kuch yordamida o'rnidan siljitish kerak. Agar yukning ishqalanish koeffitsienti k ga tengligi ma'lum bo'lsa, yukni siljitishga eng kam kuch sarflash uchun bu kuchni gorizontga nisbatan qancha og'dirish kerak?

1590. a radiusli yarim shar formasiga ega bo'lgan chashka ichiga $l > 2a$ uzunlikdagi sterjen' tushirildi. Sterjenning muvozanat holatini toping.

14. egri chiziqlarning urinishi. egrilik doirasi. evolyuta

1591. $y = kx + b$ to'g'ri chiziqning k va b parametrlarini shunday tanlangki, u $y = x^3 - 3x^2 + 2$ egri chiziq bilan birinchi tartibdan yuqori bo'lgan urinishga ega bo'lsin.

1592. a , b va c parametrlarning qanday qiymatlarida

$$y = ax^2 + bx + c$$

parabola $x = x_0$ nuqtada $y = e^x$ egri chiziq bilan 2-tartibli urinishga ega bo'ladi?

1593. Quyidagi egri chiziqlar $x = 0$ nuqtada Ox o'qi bilan qanday urinish tartibiga ega:

a) $y = 1 - \cos x$; b) $y = \operatorname{tg} x - \sin x$; v) $y = e^x - \left(1 + x + \frac{x^2}{2}\right)$.

1594. $x \neq 0$ da $y = e^{-\frac{1}{x^2}}$ va $x = 0$ da $y = 0$ bo'lgan egri chiziq $x = 0$ nuqtada Ox o'qi bilan cheksiz tartibli urinishga ega ekanligini isbotlang.

1595. $xy = 1$ giperbolaning a) $M(1, 1)$; b) $N(100; 0,01)$ nuqtalardagi egrilik radiusini va markazini toping.

Quyidagi egri chiziqlarning egrilik radiusini toping (1596-1602):

1596. Parabola: $y^2 = 2px$.

1597. ellips: $\frac{x^2}{a^2} + \frac{y^2}{b^2} = 1$ ($a \geq b > 0$).

1598. Giperbola: $\frac{x^2}{a^2} - \frac{y^2}{b^2} = 1$.

1599. Astroida: $x^{\frac{2}{3}} + y^{\frac{2}{3}} = a^{\frac{2}{3}}$.

1600. ellips: $x = a \cos t$, $y = b \sin t$.

1601. TSikloida: $x = a(t - \sin t)$, $y = a(1 - \cos t)$.

1602. Doira evol'ventasi: $x = a(\cos t + t \sin t)$, $y = a(\sin t - t \cos t)$.

1603. Ushbu

$$y^2 = 2px - qx^2$$

2-tartibli egri chiziqning egrilik radiusi normal kesmasining kubiga proporsional ekanligini isbotlang.

1604. Qutb koordinatalarda berilgan egri chiziqning egrilik radiusining formulasini yozing.

Qutb koordinatalarda berilgan egri chiziqlarning egrilik radiusini aniqlang (parametrlar musbat, 1605-1608):

1605. Arximed spirali: $r = aj$.

1606. Logarifmik spiral': $r = ae^{mj}$.

1607. Kardioda: $r = a(1 + \cos j)$.

1608. Lemniskata: $r^2 = a^2 \cos 2j$.

1609. $y = \ln x$ egri chiziqda egriligi eng katta bo'lgan nuqtani toping.

1610. Ushbu

$$y = \frac{kx^3}{6} \quad (0 \leq x < +\infty, \quad k > 0)$$

kubik parabola x nuqtada $\frac{1}{1000}$ ga teng eng katta egrilikka ega. SHu x nuqtani toping.

Tenglamalarni tuzing (1611-1615):

1611. $y^2 = 2px$ parabola evolyutasi tenglamasini.

1612. $\frac{x^2}{a^2} + \frac{y^2}{b^2} = 1$ ellips evolyutasi tenglamasini.

1613. $x^{\frac{2}{3}} + y^{\frac{2}{3}} = a^{\frac{2}{3}}$ astroida evolyutasi tenglamasini.

1614. $x = a \ln \frac{a + \sqrt{a^2 - y^2}}{y} - \sqrt{a^2 - y^2}$ traktrisa evolyutasi tenglamasini.

1615. $r = ae^{mj}$ logarifmik spiral' evolyutasi tenglamasini.

1616. Ushbu

$$x = a(t - \sin t), \quad y = a(1 - \cos t)$$

tsikloida evolyutasi – bu berilgan tsikloida bilan faqat joylashishiga ko`ra farq qiladigan tsikloida ekanligini isbotlang.

15. Tenglamalarni taqribiy echish

Proportsional qismlar (vatarlar usuli) qoidasidan foydalanib, quyidagi tenglamalarning ildizlarini 0,001 aniqlikda toping (1617-1620):

1617. $x^3 - 6x + 2 = 0$.

1618. $x^4 - x - 1 = 0$.

1619. $x - 0,1 \sin x = 2$.

1620. $\cos x = x^2$.

N'yuton usulidan foydalanib, quyidagi tenglamalarning ildizlarini ko`rsatilgan aniqlikda toping:

1621. $x^2 + \frac{1}{x^2} = 10x$ (10^{-3} aniqlikda).

1622. $x \lg x = 1$ (10^{-4} aniqlikda).

1623. $\cos x \cdot \operatorname{ch} x = 1$ (10^{-4} aniqlikda).

1624. $x + e^x = 0$ (10^{-3} aniqlikda, ikkita musbat ildizi).

1625. $x \operatorname{th} x = 1$ (10^{-6} aniqlikda).

1626. Quyidagi tenglamaning birinchi uchta musbat ildizlarini 0,001 aniqlikda toping:

$$\operatorname{tg} x = x.$$

1627. Quyidagi tenglamaning ikkita musbat ildizlarini 10^{-3} aniqlikda toping:

$$\operatorname{ctg} x = \frac{1}{x} - \frac{x}{2}.$$

III BO`LIM ANIQMAS INTEGRAL

1. Sodda aniqmas integrallar

Integrallar jadvalidan foydalanib, quyidagi integrallarni toping (1628-1653):

- | | |
|--------------------------------------------------------------------------------|--------------------------------------------------------------------|
| 1628. $\int (3-x^2)^3 dx$. | 1629. $\int x^2 (5-x)^4 dx$. |
| 1630. $\int (1-x)(1-2x)(1-3x) dx$. | 1631. $\int \left(\frac{1-x}{x}\right)^2 dx$. |
| 1632. $\int \left(\frac{a}{x} + \frac{a^2}{x^2} + \frac{a^3}{x^3}\right) dx$. | 1633. $\int \frac{x+1}{\sqrt{x}} dx$. |
| 1634. $\int \frac{\sqrt{x} - 2\sqrt[3]{x^2} + 1}{\sqrt[4]{x}} dx$. | 1635. $\int \frac{(1-x)^3}{x\sqrt[3]{x}} dx$. |
| 1636. $\int \left(1 - \frac{1}{x^2}\right) \sqrt{x\sqrt{x}} dx$. | 1637. $\int \frac{(\sqrt{2x} - \sqrt[3]{3x})^2}{x} dx$. |
| 1638. $\int \frac{\sqrt{x^4 + x^{-4} + 2}}{x^3} dx$. | 1639. $\int \frac{x^2 dx}{1+x^2}$. |
| 1640. $\int \frac{x^2 dx}{1-x^2}$. | 1641. $\int \frac{x^2 + 3}{x^2 - 1} dx$. |
| 1642. $\int \frac{\sqrt{1+x^2} + \sqrt{1-x^2}}{\sqrt{1-x^4}} dx$. | 1643. $\int \frac{\sqrt{x^2+1} - \sqrt{x^2-1}}{\sqrt{x^4-1}} dx$. |
| 1644. $\int (2^x + 3^x)^2 dx$. | 1645. $\int \frac{2^{x+1} - 5^{x-1}}{10^x} dx$. |
| 1646. $\int \frac{e^{3x} + 1}{e^x + 1} dx$. | 1647. $\int (1 + \sin x + \cos x) dx$. |
| 1648. $\int \sqrt{1 - \sin 2x} dx (0 \leq x \leq \pi)$. | 1649. $\int \operatorname{ctg}^2 x dx$. |
| 1650. $\int \operatorname{tg}^2 x dx$. | 1651. $\int (a \operatorname{sh} x + b \operatorname{ch} x) dx$. |
| 1652. $\int \operatorname{th}^2 x dx$. | 1653. $\int \operatorname{cth}^2 x dx$. |

1654. Agar $\int f(x) dx = F(x) + C$ bo`lsa, u holda quyidagini isbotlang:

$$\int f(ax+b) dx = \frac{1}{a} F(ax+b) + C \quad (a \neq 0).$$

Integrallarni toping (1655-1673):

- | | |
|----------------------------------------|--------------------------------------------------|
| 1655. $\int \frac{dx}{x+a}$. | 1656. $\int (2x-3)^{10} dx$. |
| 1657. $\int \sqrt[3]{1-3x} dx$. | 1658. $\int \frac{dx}{\sqrt{2-5x}}$. |
| 1659. $\int \frac{dx}{(5x-2)^{5/2}}$. | 1660. $\int \frac{\sqrt[5]{1-2x+x^2}}{1-x} dx$. |
| 1661. $\int \frac{dx}{2+3x^2}$. | 1662. $\int \frac{dx}{2-3x^2}$. |

1663. $\int \frac{dx}{\sqrt{2-3x^2}}$.

1665. $\int (e^{-x} + e^{-2x}) dx$.

1667. $\int \frac{dx}{\sin^2\left(2x + \frac{p}{4}\right)}$.

1669. $\int \frac{dx}{1-\cos x}$.

1671. $\int [sh(2x+1) + ch(2x-1)] dx$.

1673. $\int \frac{dx}{sh^2 \frac{x}{2}}$.

Integral ostidagi ifodada almashtirish bajarib, quyidagi integrallarni toping (1674-1720):

1674. $\int \frac{x dx}{\sqrt{1-x^2}}$.

1676. $\int \frac{x dx}{3-2x^2}$.

1678. $\int \frac{x dx}{4+x^4}$.

1680. $\int \frac{dx}{(1+x)\sqrt{x}}$.

Y o`ll a n m a. $\frac{dx}{\sqrt{x}} = 2d(\sqrt{x})$.

1683. $\int \frac{dx}{x\sqrt{x^2-1}}$.

1685. $\int \frac{x dx}{(x^2-1)^{3/2}}$.

1687. $\int \frac{dx}{\sqrt{x(1+x)}}$.

1689. $\int xe^{-x^2} dx$.

1691. $\int \frac{dx}{e^x + e^{-x}}$.

1693. $\int \frac{\ln^2 x}{x} dx$.

1695. $\int \sin^5 x \cos x dx$.

1697. $\int tg x dx$.

1664. $\int \frac{dx}{\sqrt{3x^2-2}}$.

1666. $\int (\sin 5x - \sin 5a) dx$.

1668. $\int \frac{dx}{1+\cos x}$.

1670. $\int \frac{dx}{1+\sin x}$.

1672. $\int \frac{dx}{ch^2 \frac{x}{2}}$.

1675. $\int x^2 \sqrt[3]{1+x^3} dx$.

1677. $\int \frac{x dx}{(1+x^2)^2}$.

1679. $\int \frac{x^3 dx}{x^8-2}$.

1681. $\int \sin \frac{1}{x} \cdot \frac{dx}{x^2}$.

1682. $\int \frac{dx}{x\sqrt{x^2+1}}$.

1684. $\int \frac{dx}{(x^2+1)^{3/2}}$.

1686. $\int \frac{x^2 dx}{(8x^3+27)^{2/3}}$.

1688. $\int \frac{dx}{\sqrt{x(1-x)}}$.

1690. $\int \frac{e^x dx}{2+e^x}$.

1692. $\int \frac{dx}{\sqrt{1+e^{2x}}}$.

1694. $\int \frac{dx}{x \ln x \ln(\ln x)}$.

1696. $\int \frac{\sin x}{\sqrt{\cos^3 x}} dx$.

1698. $\int ctg x dx$.

$$1699. \int \frac{\sin x + \cos x}{\sqrt[3]{\sin x - \cos x}} dx.$$

$$1700.1. \int \frac{\sin x}{\sqrt{\cos 2x}} dx.$$

$$1700.3. \int \frac{sh x}{\sqrt{ch 2x}} dx.$$

$$1702. \int \frac{dx}{\sin^2 x + 2 \cos^2 x}.$$

$$1704. \int \frac{dx}{\cos x}.$$

$$1706. \int \frac{dx}{ch x}.$$

$$1708. \int \frac{dx}{ch^2 x \sqrt[3]{th^2 x}}.$$

$$1710. \int \frac{dx}{(\arcsin x)^2 \sqrt{1-x^2}}.$$

$$1712. \int \frac{x^2 + 1}{x^4 + 1} dx.$$

Yo'llan ma. $\left(1 + \frac{1}{x^2}\right) dx = d\left(x - \frac{1}{x}\right).$

$$1715. \int \frac{x^{n/2} dx}{\sqrt{1+x^{n+2}}}.$$

$$1717. \int \frac{\cos x dx}{\sqrt{2 + \cos 2x}}.$$

$$1719. \int \frac{2^x \cdot 3^x}{9^x - 4^x} dx.$$

YOyish usulidan foydalanib, quyidagi integrallarni hisoblang (1721-1765):

$$1721. \int x^2 (2 - 3x^2)^2 dx.$$

$$1722. \int \frac{1+x}{1-x} dx.$$

$$1724. \int \frac{x^3}{3+x} dx.$$

$$1726. \int \frac{(2-x)^2}{2-x^2} dx.$$

$$1728. \int \frac{x^5}{x+1} dx.$$

$$1730. \int x \sqrt{2-5x} dx.$$

$$1700. \int \frac{\sin x \cos x}{\sqrt{a^2 \sin^2 x + b^2 \cos^2 x}} dx.$$

$$1700.2. \int \frac{\cos x}{\sqrt{\cos 2x}} dx.$$

$$1701. \int \frac{dx}{\sin^2 x \sqrt[4]{ctg x}}.$$

$$1703. \int \frac{dx}{\sin x}.$$

$$1705. \int \frac{dx}{sh x}.$$

$$1707. \int \frac{sh x ch x}{\sqrt{sh^4 x + ch^4 x}} dx.$$

$$1709. \int \frac{arctg x}{1+x^2} dx.$$

$$1711. \int \sqrt{\frac{\ln(x + \sqrt{1+x^2})}{1+x^2}} dx.$$

$$1713. \int \frac{x^2 - 1}{x^4 + 1} dx.$$

$$1714. \int \frac{x^4 dx}{(x^5 + 1)^4}.$$

$$1716. \int \frac{1}{1-x^2} \ln \frac{1+x}{1-x} dx.$$

$$1718. \int \frac{\sin x \cos x}{\sin^4 x + \cos^4 x} dx.$$

$$1720. \int \frac{x dx}{\sqrt{1+x^2 + \sqrt{(1+x^2)^3}}}.$$

$$1721.1. \int x(1-x)^{10} dx.$$

$$1723. \int \frac{x^2}{1+x} dx.$$

$$1725. \int \frac{(1+x)^2}{1+x^2} dx.$$

$$1727. \int \frac{x^2}{(1-x)^{100}} dx.$$

$$1729. \int \frac{dx}{\sqrt{x+1} + \sqrt{x-1}}.$$

$$1731. \int \frac{x dx}{\sqrt[3]{1-3x}}.$$

Y o`llan ma. $x \equiv -\frac{1}{5}(2-5x) + \frac{2}{5}$.

1733. $\int \frac{dx}{(x-1)(x+3)}$.

Y o`llan ma. $1 \equiv \frac{1}{4}[(x+3)-(x-1)]$.

1736. $\int \frac{dx}{(x^2-2)(x^2+3)}$.

1738. $\int \frac{x dx}{x^4+3x^2+2}$.

1740. $\int \frac{dx}{(x^2+a^2)(x^2+b^2)} (a^2 \neq b^2)$.

1742. $\int \cos^2 x dx$.

1744. $\int \sin 3x \cdot \sin 5x dx$.

1746. $\int \sin\left(2x - \frac{p}{6}\right) \cos\left(3x + \frac{p}{6}\right) dx$.

1748. $\int \cos^3 x dx$.

1750. $\int \cos^4 x dx$.

1752. $\int tg^3 x dx$.

1754. $\int \frac{dx}{\sin^2 x \cos^2 x}$.

Y o`llan ma. $1 \equiv \sin^2 x + \cos^2 x$.

1757. $\int \frac{\cos^3 x}{\sin x} dx$.

1759. $\int \frac{dx}{1+e^x}$.

1761. $\int sh^2 x dx$.

1763. $\int sh x sh 2x dx$.

1765. $\int \frac{dx}{sh^2 x ch^2 x}$.

O`zgaruvchini almashtirish usulidan foydalanib, quyidagi integrallarni toping (1766-1777):

1766. $\int x^2 \sqrt[3]{1-x} dx$.

1768. $\int \frac{x^2}{\sqrt{2-x}} dx$.

1770. $\int x^5 (2-5x^3)^{2/3} dx$.

1772. $\int \frac{\sin x \cos^3 x}{1+\cos^2 x} dx$.

1732. $\int x^3 \sqrt[3]{1+x^2} dx$.

1734. $\int \frac{dx}{x^2+x-2}$.

1735. $\int \frac{dx}{(x^2+1)(x^2+2)}$.

1737. $\int \frac{x dx}{(x+2)(x+3)}$.

1739. $\int \frac{dx}{(x+a)^2(x+b)^2} (a \neq b)$.

1741. $\int \sin^2 x dx$.

1743. $\int \sin x \sin(x+a) dx$.

1745. $\int \cos \frac{x}{2} \cdot \cos \frac{x}{3} dx$.

1747. $\int \sin^3 x dx$.

1749. $\int \sin^4 x dx$.

1751. $\int ctg^2 x dx$.

1753. $\int \sin^2 3x \sin^3 2x dx$.

1755. $\int \frac{dx}{\sin^2 x \cdot \cos x}$.

1756. $\int \frac{dx}{\sin x \cos^3 x}$.

1758. $\int \frac{dx}{\cos^4 x}$.

1760. $\int \frac{(1+e^x)^2}{1+e^{2x}} dx$.

1762. $\int ch^2 x dx$.

1764. $\int ch x \cdot ch 3x dx$.

1767. $\int x^3 (1-5x^2)^{10} dx$.

1769. $\int \frac{x^5}{\sqrt{1-x^2}} dx$.

1771. $\int \cos^5 x \cdot \sqrt{\sin x} dx$.

1773. $\int \frac{\sin^2 x}{\cos^6 x} dx$.

$$1774. \int \frac{\ln x dx}{x\sqrt{1+\ln x}}.$$

$$1776. \int \frac{dx}{\sqrt{1+e^x}}.$$

$$1775. \int \frac{dx}{e^{x/2} + e^x}.$$

$$1777. \int \frac{\arctg \sqrt{x}}{\sqrt{x}} \cdot \frac{dx}{1+x}.$$

$x = a \sin t$, $x = a \operatorname{tg} t$, $x = a \sin^2 t$ va h.z. kabi trigonometrik almashtirishlardan foydalanib, quyidagi integrallarni toping (parametrlar musbat, 1778-1785):

$$1778. \int \frac{dx}{(1-x^2)^{3/2}}.$$

$$1780. \int \sqrt{1-x^2} dx.$$

$$1782. \int \sqrt{\frac{a+x}{a-x}} dx.$$

$$1784. \int \frac{dx}{\sqrt{(x-a)(b-x)}}.$$

$$1779. \int \frac{x^2 dx}{\sqrt{x^2-2}}.$$

$$1781. \int \frac{dx}{(x^2+a^2)^{3/2}}.$$

$$1783. \int x \sqrt{\frac{x}{2a-a}} dx.$$

$$1785. \int \sqrt{(x-a)(b-x)} dx.$$

Y o`ll a n m a. $x-a = (b-a) \sin^2 t$.

$x = a \operatorname{sh} t$, $x = a \operatorname{ch} t$ va h.z. kabi giperbolik almashtirishlardan foydalanib, quyidagi integrallarni toping (parametrlar musbat, 1786-1790):

$$1786. \int \sqrt{a^2+x^2} dx.$$

$$1788. \int \sqrt{\frac{x-a}{x+a}} dx.$$

$$1790. \int \sqrt{(x+a)(x+b)} dx.$$

$$1787. \int \frac{x^2}{\sqrt{a^2+x^2}} dx.$$

$$1789. \int \frac{dx}{\sqrt{(x+a)(x+b)}}.$$

Y o`ll a n m a. $x+a = (b-a) \operatorname{sh}^2 t$.

Bo`laklab integrallash usulidan foydalanib, quyidagi integrallarni toping (1791-1810):

$$1791. \int \ln x dx.$$

$$1793. \int \left(\frac{\ln x}{x} \right)^2 dx.$$

$$1795. \int x e^{-x} dx.$$

$$1797. \int x^3 e^{-x^2} dx.$$

$$1799. \int x^2 \sin 2x dx.$$

$$1801. \int x^3 \operatorname{ch} 3x dx.$$

$$1803. \int \arcsin x dx.$$

$$1805. \int x^2 \arccos x dx.$$

$$1807. \int \ln \left(x + \sqrt{1+x^2} \right) dx.$$

$$1809. \int \arctg \sqrt{x} dx.$$

Integrallarni toping (1811-1835):

$$1811. \int x^5 e^{x^2} dx.$$

$$1792. \int x^n \ln x dx \quad (n \neq -1).$$

$$1794. \int \sqrt{x} \ln^2 x dx.$$

$$1796. \int x^2 e^{-2x} dx.$$

$$1798. \int x \cos x dx.$$

$$1800. \int x \operatorname{sh} x dx.$$

$$1802. \int \arctg x dx.$$

$$1804. \int x \operatorname{arctg} x dx.$$

$$1806. \int \frac{\arcsin x}{x^2} dx.$$

$$1808. \int x \ln \frac{1+x}{1-x} dx.$$

$$1810. \int \sin x \cdot \ln(\operatorname{tg} x) dx.$$

$$1812. \int (\arcsin x)^2 dx$$

$$1813. \int x(\arctg x)^2 dx.$$

$$1815. \int \frac{x \ln(x + \sqrt{1+x^2})}{\sqrt{1+x^2}} dx.$$

$$1817. \int \frac{dx}{(a^2 + x^2)^2}.$$

$$1819. \int \sqrt{x^2 + a} dx.$$

$$1821. \int x \sin^2 x dx.$$

$$1823. \int x \sin \sqrt{x} dx.$$

$$1825. \int \frac{e^{\arctg x}}{(1+x^2)^{3/2}} dx.$$

$$1827. \int \cos(\ln x) dx.$$

$$1829. \int e^{ax} \sin bx dx.$$

$$1831. \int (e^x - \cos x)^2 dx.$$

$$1833. \int \frac{\ln(\sin x)}{\sin^2 x} dx.$$

$$1835. \int \frac{xe^x}{(x+1)^2} dx.$$

Integrallarni toping (1836-1849, 1851-1865):

$$1836. \int \frac{dx}{a+bx^2} \quad (ab \neq 0).$$

$$1838. \int \frac{dx}{3x^2 - 2x - 1}.$$

$$1840. \int \frac{(x+1)}{x^2 + x + 1} dx.$$

$$1842. \int \frac{x^3 dx}{x^4 - x^2 + 2}.$$

$$1844. \int \frac{dx}{3 \sin^2 x - 8 \sin x \cos x + 5 \cos^2 x}.$$

$$1846. \int \frac{dx}{\sqrt{a+bx^2}} \quad (b \neq 0).$$

$$1848. \int \frac{ax}{\sqrt{x+x^2}}.$$

1850. Agar $y = ax^2 + bx + c$ ($a \neq 0$) bo'lsa, u holda quyidagilarni isbotlang:

$$\int \frac{dx}{\sqrt{y}} = \frac{1}{\sqrt{a}} \ln \left| \frac{y'}{2} + \sqrt{ay} \right| + C, \quad a > 0$$

$$1814. \int x^2 \ln \frac{1-x}{1+x} dx.$$

$$1816. \int \frac{x^2}{(1+x^2)^2} dx.$$

$$1818. \int \sqrt{a^2 - x^2} dx.$$

$$1820. \int x^2 \sqrt{a^2 + x^2} dx.$$

$$1822. \int e^{\sqrt{x}} dx.$$

$$1824. \int \frac{xe^{\arctg x}}{(1+x^2)^{3/2}} dx.$$

$$1826. \int \sin(\ln x) dx.$$

$$1828. \int e^{ax} \cos bx dx.$$

$$1830. \int e^{2x} \sin^2 x dx.$$

$$1832. \int \frac{\operatorname{arcctg} e^x}{e^x} dx.$$

$$1834. \int \frac{x dx}{\cos^2 x}.$$

$$1837. \int \frac{dx}{x^2 - x + 2}.$$

$$1839. \int \frac{x dx}{x^4 - 2x^2 - 1}.$$

$$1841. \int \frac{x dx}{x^2 - 2x \cos a + 1}.$$

$$1843. \int \frac{x^5 dx}{x^6 - x^3 - 2}.$$

$$1845. \int \frac{dx}{\sin x + 2 \cos x + 3}.$$

$$1847. \int \frac{dx}{\sqrt{1-2x-x^2}}.$$

$$1849. \int \frac{dx}{\sqrt{2x^2 - x + 2}}.$$

$$\int \frac{dx}{\sqrt{y}} = \frac{1}{\sqrt{-a}} \arcsin \frac{-y'}{\sqrt{b^2 - 4ac}} + C, \quad a < 0.$$

$$1851. \int \frac{x dx}{\sqrt{5+x-x^2}}.$$

$$1852. \int \frac{x+1}{\sqrt{x^2+x+1}} dx.$$

$$1853. \int \frac{x dx}{\sqrt{1-3x^2-2x^4}}.$$

$$1853.1. \int \frac{\cos x dx}{\sqrt{1+\sin x+\cos^2 x}}.$$

$$1854. \int \frac{x^3 dx}{\sqrt{x^4-2x^2-1}}.$$

$$1855. \int \frac{x+x^3}{\sqrt{1+x^2-x^4}} dx.$$

$$1856. \int \frac{dx}{x\sqrt{x^2+x+1}}.$$

$$1857. \int \frac{dx}{x^2\sqrt{x^2+x-1}}.$$

$$1858. \int \frac{dx}{(x+1)\sqrt{x^2+1}}.$$

$$1859. \int \frac{dx}{(x-1)\sqrt{x^2-2}}.$$

$$1860. \int \frac{dx}{(x+2)^2 \sqrt{x^2+2x-5}}.$$

$$1861. \int \sqrt{2+x-x^2} dx.$$

$$1862. \int \sqrt{2+x+x^2} dx.$$

$$1863. \int \sqrt{x^4+2x^2-1} x dx.$$

$$1864. \int \frac{1-x+x^2}{x\sqrt{1+x-x^2}} dx.$$

$$1865. \int \frac{x^2+1}{x\sqrt{x^4+1}} dx.$$

2. Ratsional funksiyalarni integrallash

Aniqmas koeffitsientlar usulidan foydalanib, quyidagi integrallarni toping (1866-1889):

$$1866. \int \frac{2x+3}{(x-2)(x+5)} dx.$$

$$1867. \int \frac{xdx}{(x+1)(x+2)(x+3)}.$$

$$1868. \int \frac{x^{10} dx}{x^2+x-2}.$$

$$1869. \int \frac{x^3+1}{x^3-5x^2+6x} dx.$$

$$1870. \int \frac{x^4}{x^4+5x^2+4} dx.$$

$$1871. \int \frac{xdx}{x^3-3x+2}.$$

$$1872. \int \frac{x^2+1}{(x+1)^2(x-1)} dx.$$

$$1873. \int \left(\frac{x}{x^2-3x+2} \right)^2 dx.$$

$$1874. \int \frac{dx}{(x+1)(x+2)^2(x+3)^3}.$$

$$1875. \int \frac{dx}{x^5+x^4-2x^3-2x^2+x+1}.$$

$$1876. \int \frac{x^2+5x+4}{x^4+5x^2+4} dx.$$

$$1877. \int \frac{dx}{(x+1)(x^2+1)}.$$

$$1878. \int \frac{dx}{(x^2-4x+4)(x^2-4x+5)}.$$

$$1879. \int \frac{xdx}{(x-1)^2(x^2+2x+2)}.$$

$$1880. \int \frac{dx}{x(1+x)(1+x+x^2)}.$$

$$1881. \int \frac{dx}{x^3+1}.$$

$$1882. \int \frac{xdx}{x^3-1}.$$

$$1883. \int \frac{dx}{x^4-1}.$$

1884. $\int \frac{dx}{x^4 + 1}$.

1886. $\int \frac{dx}{x^6 + 1}$.

1888. $\int \frac{dx}{x^5 - x^4 + x^3 - x^2 + x - 1}$.

1890. Ushbu

$$\int \frac{ax^2 + bx + c}{x^3(x-1)^2} dx$$

integral qanday shartlar bajarilganda ratsional funksiya bo`ladi?

Ostrogradskiy usulidan foydalanib, integrallarni toping (1891-1897):

1891. $\int \frac{x dx}{(x-1)^2(x+1)^3}$.

1893. $\int \frac{dx}{(x^2 + 1)^3}$.

1895. $\int \frac{dx}{(x^4 + 1)^2}$.

1897. $\int \frac{dx}{(x^4 - 1)^3}$.

1885. $\int \frac{dx}{x^4 + x^2 + 1}$.

1887. $\int \frac{dx}{(1+x)(1+x^2)(1+x^3)}$.

1889. $\int \frac{x^2 dx}{x^4 + 3x^3 + \frac{9}{2}x^2 + 3x + 1}$.

1892. $\int \frac{dx}{(x^3 + 1)^2}$.

1894. $\int \frac{x^2 dx}{(x^2 + 2x + 2)^2}$.

1896. $\int \frac{x^2 + 3x - 2}{(x-1)(x^2 + x + 1)^2} dx$.

Quyidagi integrallarning algebraik qismini ajrating (1898-1900):

1898. $\int \frac{x^2 + 1}{(x^4 + x^2 + 1)^2} dx$.

1899. $\int \frac{dx}{(x^3 + x + 1)^3}$.

1900. $\int \frac{4x^5 - 1}{(x^5 + x + 1)^2} dx$.

1901. Integralni toping: $\int \frac{dx}{x^4 + 2x^3 + 3x^2 + 2x + 1}$.

1902. Qanday shartlar bajarilganda ushbu

$$\int \frac{ax^2 + 2bx + g}{(ax^2 + 2bx + c)^2} dx$$

integral ratsional funksiyaning ifodalaydi?

Turli usullardan foydalanib, quyidagi integrallarni toping (1903-1920):

1903. $\int \frac{x^3}{(x-1)^{100}} dx$.

1904. $\int \frac{x dx}{x^8 - 1}$.

1905. $\int \frac{x^3 dx}{x^8 + 3}$.

1906. $\int \frac{x^2 + x}{x^6 + 1} dx$.

1907. $\int \frac{x^4 - 3}{x(x^8 + 3x^4 + 2)} dx$.

1908. $\int \frac{x^4 dx}{(x^{10} - 10)^2}$.

$$1909. \int \frac{x^{11} dx}{x^8 + 3x^4 + 2}.$$

$$1910. \int \frac{x^9 dx}{(x^{10} + 2x^5 + 2)^2}.$$

$$1911. \int \frac{x^{2n-1}}{x^n + 1} dx.$$

$$1912. \int \frac{x^{3n-1}}{(x^{2n} + 1)^2} dx.$$

$$1913. \int \frac{dx}{x(x^{10} + 2)}.$$

$$1914. \int \frac{dx}{x(x^{10} + 1)^2}.$$

$$1915. \int \frac{1 - x^7}{x(1 + x^7)} dx.$$

$$1916. \int \frac{x^4 - 1}{x(x^4 - 5)(x^5 - 5x + 1)} dx.$$

$$1917. \int \frac{x^2 + 1}{x^4 + x^2 + 1} dx.$$

$$1918. \int \frac{x^2 - 1}{x^4 + x^3 + x^2 + x + 1} dx.$$

$$1919. \int \frac{x^5 - x}{x^8 + 1} dx.$$

$$1920. \int \frac{x^4 + 1}{x^6 + 1} dx.$$

1921. Ushbu

$$I_n = \int \frac{dx}{(ax^2 + bx + c)^n} \quad (a \neq 0)$$

integralni hisoblash uchun rekurrent formulani keltirib chiqaring.

Bu formuladan foydalanib, quyidagi integralni hisoblang:

$$I_3 = \int \frac{dx}{(x^2 + x + 1)^3}.$$

Y o`ll a n m a. Ayniyatdan foydalaning: $4a(ax^2 + bx + c) = (2ax + b)^2 + (4ac - b^2)$

1922. Ushbu

$$I = \int \frac{dx}{(x+a)^m (x+b)^n} \quad (m, n \in \mathbb{N})$$

integralni hisoblash uchun $t = \frac{x+a}{x+b}$ almashtirish bajaring.

Bu almashtirishdan foydalanib, quyidagi integralni toping:

$$\int \frac{dx}{(x-2)^2 (x+3)^3}.$$

1923. Agar $P_n(x)$ - x o`zgaruvchiga nisbatan n -darajali ko`phad bo`lsa, u holda quyidagi integralni hisoblang:

$$\int \frac{P_n(x)}{(x-a)^{n+1}} dx.$$

Y o`ll a n m a. Teylor formulasini qo`llang.

1924. $R(x) = R^*(x^2)$ bo`lsin, bunda R^* - ratsional funksiya. $R(x)$ funksiyaning ratsional kasrlarga yoyilmasi qanday xususiyatlarga ega?

1925. Hisoblang:

$$\int \frac{dx}{1+x^{2n}} \quad (n - \text{butun musbat son}).$$

3. Ba`zi irratsional funksiyalarni integrallash

Integral ostidagi funksiyalarni ratsional funksiyaga keltirib, quyidagi integrallarni hisoblang (1926-1935):

$$1926. \int \frac{dx}{1 + \sqrt{x}}.$$

$$1927. \int \frac{dx}{x(1 + 2\sqrt{x} + \sqrt[3]{x})}.$$

$$1928. \int \frac{x\sqrt[3]{2+x}}{x + \sqrt[3]{2+x}} dx.$$

$$1929. \int \frac{1 - \sqrt{x+1}}{1 + \sqrt[3]{x+1}} dx.$$

$$1930. \int \frac{dx}{(1 + \sqrt[4]{x})^3 \sqrt{x}}.$$

$$1931. \int \frac{\sqrt{x+1} - \sqrt{x-1}}{\sqrt{x+1} + \sqrt{x-1}} dx.$$

$$1932. \int \frac{dx}{\sqrt[3]{(x+1)^2 (x-1)^4}}.$$

$$1933. \int \frac{x dx}{\sqrt[4]{x^3 (a-x)}} \quad (a > 0).$$

$$1934. \int \frac{dx}{\sqrt[n]{(x-a)^{n+1} (x-b)^{n-1}}} \quad (n - \text{natural son}).$$

$$1935. \int \frac{dx}{1 + \sqrt{x} + \sqrt{1+x}}.$$

Y o`ll a n m a. $x = \left(\frac{u^2 - 1}{2u} \right)^2.$

1936. R - ratsional funksiya va p, q, n - butun sonlar bo`lsin. Agar $p + q = kn$ ($k \in \mathbb{Z}$) bo`lsa, u holda quyidagi integral elementar funksiya ekanligini isbotlang:

$$\int R \left[x, (x-a)^{p/n} (x-b)^{q/n} \right] dx.$$

Quyidagi oddiy kvadratik irratsional funksiyalarning integralini toping (1937-1942):

$$1937. \int \frac{x^2}{\sqrt{1+x+x^2}} dx.$$

$$1938. \int \frac{dx}{(x+1)\sqrt{x^2+x+1}}.$$

$$1939. \int \frac{dx}{(1-x)^2 \sqrt{1-x^2}}.$$

$$1940. \int \frac{\sqrt{x^2+2x+2}}{x} dx.$$

$$1941. \int \frac{x dx}{(1+x)\sqrt{1-x-x^2}}.$$

$$1942. \int \frac{1-x+x^2}{\sqrt{1+x-x^2}} dx.$$

Ushbu

$$\int \frac{P_n(x)}{y} dx = Q_{n-1}(x)y + I \int \frac{dx}{y}$$

formulani qo`llab, quyidagi integrallarni toping, bunda $y = \sqrt{ax^2 + bx + c}$, $P_n(x)$ - n - darajali ko`phad, $Q_{n-1}(x)$ - $(n-1)$ - darajali ko`phad va I - o`zgarmas son (1943-1950):

$$1943. \int \frac{x^3}{\sqrt{1+2x-x^2}} dx.$$

$$1944. \int \frac{x^{10} dx}{\sqrt{1+x^2}}.$$

$$1945. \int x^4 \sqrt{a^2 - x^2} dx.$$

$$1946. \int \frac{x^3 - 6x^2 + 11x - 6}{\sqrt{x^2 + 4x + 3}} dx.$$

$$1947. \int \frac{dx}{x^3 \sqrt{x^2 + 1}}.$$

$$1948. \int \frac{dx}{x^4 \sqrt{x^2 - 1}}.$$

$$1949. \int \frac{dx}{(x-1)^3 \sqrt{x^2 + 3x + 1}}.$$

$$1950. \int \frac{dx}{(x+1)^5 \sqrt{x^2 + 2x}}.$$

1951. Qanday shartlar bajarilganda ushbu

$$\int \frac{a_1x^2 + b_1x + c_1}{\sqrt{ax^2 + bx + c}} dx$$

integral algebraik funksiyani ifodalaydi?

$\frac{P(x)}{Q(x)}$ ratsional funksiyani oddiy kasrlarga yoyib, $\int \frac{P(x)}{Q(x)y} dx$ integralni toping, bunda

$$y = \sqrt{ax^2 + bx + c}.$$

1952. $\int \frac{x dx}{(x-1)^2 \sqrt{1+2x-x^2}}.$

1953. $\int \frac{x dx}{(x^2-1)\sqrt{x^2-x-1}}.$

1954. $\int \frac{\sqrt{x^2+x+1}}{(x+1)^2} dx.$

1955. $\int \frac{x^3}{(1+x)\sqrt{1+2x-x^2}} dx.$

1956. $\int \frac{x dx}{(x^2-3x+2)\sqrt{x^2-4x+3}}.$

1957. $\int \frac{dx}{(1+x^2)\sqrt{1-x^2}}.$

1958. $\int \frac{dx}{(x^2+1)\sqrt{x^2-1}}.$

1959. $\int \frac{dx}{(1-x^4)\sqrt{1+x^2}}.$

1960. $\int \frac{\sqrt{x^2+2}}{x^2+1} dx.$

Kvadratik ko'phadlarni kanonik ko'rinishga keltirib, quyidagi integrallarni hisoblang (1961-1963):

1961. $\int \frac{dx}{(x^2+x+1)\sqrt{x^2+x-1}}.$

1962. $\int \frac{x^2 dx}{(4-2x+x^2)\sqrt{2+2x-x^2}}.$

1963. $\int \frac{(x+1) dx}{(x^2+x+1)\sqrt{x^2+x+1}}.$

1964. $x = \frac{a+bt}{1+t}$ kasr-chiziqli almashtirish yordamida quyidagi integralni toping:

$$\int \frac{dx}{(x^2-x+1)\sqrt{x^2+x+1}}.$$

1965. Hisoblang: $\int \frac{dx}{(x^2+2)\sqrt{2x^2-2x+5}}.$

Ushbu

1) agar $a > 0$ bo'lsa, $\sqrt{ax^2 + bx + c} = \pm\sqrt{ax} + z$;

2) agar $c > 0$ bo'lsa, $\sqrt{ax^2 + bx + c} = xz \pm \sqrt{c}$;

3) $\sqrt{a(x-x_1)(x-x_2)} = z(x-x_1)$

Eyler almashtirishlarini qo'llab, quyidagi integrallarni toping (1966-1970):

1966. $\int \frac{dx}{x + \sqrt{x^2 + x + 1}}.$

1967. $\int \frac{dx}{1 + \sqrt{1 - 2x - x^2}}.$

1968. $\int x\sqrt{x^2 - 2x + 2} dx.$

1969. $\int \frac{x - \sqrt{x^2 + 3x + 2}}{x + \sqrt{x^2 + 3x + 2}} dx.$

$$1970. \int \frac{dx}{\left[1 + \sqrt{x(1+x)}\right]^2}.$$

Turli usullardan foydalanib, quyidagi integrallarni toping (1971-1979):

$$1971. \int \frac{dx}{\sqrt{x^2+1} - \sqrt{x^2-1}}.$$

$$1972. \int \frac{x dx}{(1-x^3)\sqrt{1-x^2}}.$$

$$1973. \int \frac{dx}{\sqrt{2} + \sqrt{1-x} + \sqrt{1+x}}.$$

$$1974. \int \frac{x + \sqrt{1+x+x^2}}{1+x + \sqrt{1+x+x^2}} dx.$$

$$1975. \int \frac{\sqrt{x(x+1)}}{\sqrt{x} + \sqrt{x+1}} dx.$$

$$1976. \int \frac{(x^2-1)dx}{(x^2+1)\sqrt{x^4+1}}.$$

$$1977. \int \frac{(x^2+1)dx}{(x^2-1)\sqrt{x^4+1}}.$$

$$1978. \int \frac{dx}{x\sqrt{x^4+2x^2-1}}.$$

$$1979. \int \frac{(x^2+1)dx}{x\sqrt{x^4+x^2+1}}.$$

1980. $\int R(x, \sqrt{ax+b}, \sqrt{cx+d}) dx$ integralni topish, bunda R - ratsional funksiya, ratsional funksiyaning integrallashga keltirilishini isbotlang.

Quyidagi (binomial differensial) integrallarni toping (1981-1989):

$$1981. \int \sqrt{x^3+x^4} dx.$$

$$1982. \int \frac{\sqrt{x}}{(1+\sqrt[3]{x})^2} dx.$$

$$1983. \int \frac{x dx}{\sqrt{1+\sqrt[3]{x^2}}}.$$

$$1984. \int \frac{x^5 dx}{\sqrt{1-x^2}}.$$

$$1985. \int \frac{dx}{\sqrt[3]{1+x^3}}.$$

$$1986. \int \frac{dx}{\sqrt[4]{1+x^4}}.$$

$$1987. \int \frac{dx}{x^6\sqrt{1+x^6}}.$$

$$1988. \int \frac{dx}{x^3\sqrt[5]{1+\frac{1}{x}}}.$$

$$1989. \int \sqrt[3]{3x-x^3} dx.$$

1990. Qanday hollarda ushbu

$$\int \sqrt{1+x^m} dx$$

integral elementar funksiyaning ifodalaydi, bunda m - ratsional son?

4. Trigonometrik funksiyalarni integrallash

Integrallarni toping (1991-2010):

$$1991. \int \cos^5 x dx.$$

$$1992. \int \sin^6 x dx.$$

$$1993. \int \cos^6 x dx.$$

$$1994. \int \sin^2 x \cos^4 x dx.$$

$$1995. \int \sin^4 x \cos^5 x dx.$$

$$1996. \int \sin^5 x \cos^5 x dx.$$

$$1997. \int \frac{\sin^3 x}{\cos^4 x} dx.$$

$$1998. \int \frac{\cos^4 x}{\sin^3 x} dx.$$

$$1999. \int \frac{dx}{\sin^3 x}.$$

$$2000. \int \frac{dx}{\cos^3 x}.$$

$$2001. \int \frac{dx}{\sin^4 x \cos^4 x}.$$

$$2002. \int \frac{dx}{\sin^3 x \cos^5 x}.$$

$$2003. \int \frac{dx}{\sin x \cos^4 x}.$$

$$2004. \int \operatorname{tg}^5 x dx.$$

$$2005. \int \operatorname{ctg}^6 x dx.$$

$$2006. \int \frac{\sin^4 x}{\cos^6 x} dx.$$

$$2007. \int \frac{dx}{\sqrt{\sin^3 x \cos^5 x}}.$$

$$2008. \int \frac{dx}{\cos x \sqrt[3]{\sin^2 x}}.$$

$$2009. \int \frac{dx}{\sqrt{\operatorname{tg} x}}.$$

$$2010. \int \frac{dx}{\sqrt[3]{\operatorname{tg} x}}.$$

2011. Quyidagi integrallar uchun pasaytirish formulalarini keltirib chiqaring:

$$a) I_n = \int \sin^n x dx; \quad b) K_n = \int \cos^n x dx \quad (n > 2)$$

va ular yordamida quyidagi integrallarni hisoblang:

$$\int \sin^6 x dx \quad \text{va} \quad \int \cos^8 x dx.$$

2012. Quyidagi integrallar uchun pasaytirish formulalarini keltirib chiqaring:

$$a) I_n = \int \frac{dx}{\sin^n x}; \quad b) K_n = \int \frac{dx}{\cos^n x} \quad (n > 2)$$

va ular yordamida quyidagi integrallarni hisoblang:

$$\int \frac{dx}{\sin^5 x} \quad \text{va} \quad \int \frac{dx}{\cos^7 x}.$$

Quyidagi integrallarni ushbu

$$I. \sin a \sin b = \frac{1}{2} [\cos(a - b) - \cos(a + b)];$$

$$II. \cos a \cos b = \frac{1}{2} [\cos(a - b) + \cos(a + b)];$$

$$III. \sin a \cos b = \frac{1}{2} [\sin(a - b) + \sin(a + b)]$$

formulalarni qo'llab toping (2013-2018):

$$2013. \int \sin 5x \cos x dx.$$

$$2014. \int \cos x \cos 2x \cos 3x dx.$$

$$2015. \int \sin x \sin \frac{x}{2} \sin \frac{x}{3} dx.$$

$$2016. \int \sin x \sin(x + a) \sin(x + b) dx.$$

$$2017. \int \cos^2 ax \cos^2 bx dx.$$

$$2018. \int \sin^3 2x \cdot \cos^2 3x dx.$$

Quyidagi integrallarni ushbu

$$\cos(a - b) \equiv \cos[(x + a) - (x + b)] \quad \text{va} \quad \sin(a - b) \equiv \sin[(x + a) - (x + b)]$$

ayniyatlarini qo'llab toping (2019-2024):

$$2019. \int \frac{dx}{\sin(x + a) \sin(x + b)}.$$

$$2020. \int \frac{dx}{\sin(x + a) \cos(x + b)}.$$

$$2021. \int \frac{dx}{\cos(x + a) \cos(x + b)}.$$

$$2022. \int \frac{dx}{\sin x - \sin a}.$$

$$2023. \int \frac{dx}{\cos x + \cos a}.$$

$$2024. \int \operatorname{tg} x \operatorname{tg}(x + a) dx.$$

$\int R(\sin x, \cos x) dx$ ko`rinishdagi integrallarni (R - ratsional funksiya) umumiy holda $\operatorname{tg} \frac{x}{2} = t$ almashtirish yordamida ratsional funksiyalarni integrallashga keltiriladi.

a) Agar

$$R(-\sin x, \cos x) \equiv -R(\sin x, \cos x)$$

yoki

$$R(\sin x, -\cos x) \equiv -R(\sin x, \cos x)$$

tenglik bajarilsa, u holda $\cos x = t$ yoki mos ravishda $\sin x = t$ almashtirish bajarish qulaydir.

b) Agar

$$R(-\sin x, -\cos x) \equiv R(\sin x, \cos x)$$

tenglik bajarilsa, u holda $\operatorname{tg} x = t$ almashtirish bajarish qulaydir.

Integrallarni toping (2025-2040):

$$2025. \int \frac{dx}{2 \sin x - \cos x + 5}.$$

$$2026. \int \frac{dx}{(2 + \cos x) \sin x}.$$

$$2027. \int \frac{\sin^2 x}{\sin x + 2 \cos x} dx.$$

$$2028. \int \frac{dx}{1 + e \cos x}; \text{ a) } 0 < e < 1; \text{ b) } e > 1.$$

$$2029. \int \frac{\sin^2 x}{1 + \sin^2 x} dx.$$

$$2030. \int \frac{dx}{a^2 \sin^2 x + b^2 \cos^2 x}.$$

$$2031. \int \frac{\cos^2 x dx}{(a^2 \sin^2 x + b^2 \cos^2 x)^2}.$$

$$2032. \int \frac{\sin x \cos x}{\sin x + \cos x} dx.$$

$$2033. \int \frac{dx}{(a \sin x + b \cos x)^2}.$$

$$2034. \int \frac{\sin x dx}{\sin^3 x + \cos^3 x}.$$

$$2035. \int \frac{dx}{\sin^4 x + \cos^4 x}.$$

$$2036. \int \frac{\sin^2 x \cos^2 x}{\sin^8 x + \cos^8 x} dx.$$

$$2037. \int \frac{\sin^2 x - \cos^2 x}{\sin^4 x + \cos^4 x} dx.$$

$$2038. \int \frac{\sin x \cos x}{1 + \sin^4 x} dx.$$

$$2039. \int \frac{dx}{\sin^6 x + \cos^6 x}.$$

$$2040. \int \frac{dx}{(\sin^2 x + 2 \cos^2 x)^2}.$$

2041. Maxrajni logarifmik ko`rinishga keltirib, quyidagi integralni hisoblang:

$$\int \frac{dx}{a \sin x + b \cos x}.$$

$$2042. \text{ Isbotlang: } \int \frac{a_1 \sin x + b_1 \cos x}{a \sin x + b \cos x} dx = Ax + B \ln |a \sin x + b \cos x| + C,$$

bunda A, B, C - o`zgarmas sonlar.

Y o` l l a n m a. Tenglikdan foydalaning:

$$a_1 \sin x + b_1 \cos x = A(a \sin x + b \cos x) + B(a \cos x - b \sin x), \quad A, B - \text{o`zgarmas sonlar.}$$

Integrallarni toping (2043-2045):

$$2043. \int \frac{\sin x - \cos x}{\sin x + 2 \cos x} dx.$$

$$2043.1. \int \frac{\sin x}{\sin x - 3 \cos x} dx.$$

$$2044. \int \frac{dx}{3 + 5 \operatorname{tg} x}.$$

$$2045. \int \frac{a_1 \sin x + b_1 \cos x}{(a \sin x + b \cos x)^2} dx.$$

2046. Isbotlang:

$$\int \frac{a_1 \sin x + b_1 \cos x + c_1}{a \sin x + b \cos x + c} dx = Ax + B \ln |a \sin x + b \cos x + c| + C \int \frac{dx}{a \sin x + b \cos x + c},$$

bunda A, B, C - o'zgarma koeffitsientlar.

Integrallarni toping (2047-2049):

$$2047. \int \frac{\sin x + 2 \cos x - 3}{\sin x - 2 \cos x + 3} dx.$$

$$2048. \int \frac{\sin x}{\sqrt{2} + \sin x + \cos x} dx.$$

$$2049. \int \frac{2 \sin x + \cos x}{3 \sin x + 4 \cos x - 2} dx.$$

2050. Isbotlang:

$$\int \frac{a_1 \sin^2 x + 2b_1 \sin x \cos x + c_1 \cos^2 x}{a \sin x + b \cos x} dx = A \sin x + B \cos x + C \int \frac{dx}{a \sin x + b \cos x},$$

bunda A, B, C - o'zgarma koeffitsientlar.

Integrallarni toping:

$$2051. \int \frac{\sin^2 x - 4 \sin x \cos x + 3 \cos^2 x}{\sin x + \cos x} dx.$$

$$2052. \int \frac{\sin^2 x - \sin x \cos x + 2 \cos^2 x}{\sin x + 2 \cos x} dx.$$

2053. Agar $(a - c)^2 + b^2 \neq 0$ bo'lsa, u holda

$$\int \frac{a_1 \sin x + b_1 \cos x}{a \sin^2 x + 2b \sin x \cos x + c \cos^2 x} dx = A \int \frac{du_1}{k_1 u_1^2 + I_1} + B \int \frac{du_2}{k_2 u_2^2 + I_2}$$

tenglikni isbotlang, bunda A, B - aniqlanma koeffitsientlar, I_1, I_2 lar esa ushbu

$$\begin{vmatrix} a - I & b \\ b & c - I \end{vmatrix} = 0 \quad (I_1 \neq I_2)$$

tenglamani ildizlari, $u_i = (a - I_i) \sin x + b \cos x$ va $k_i = \frac{1}{a - I_i}$ ($i = 1, 2$).

Integrallarni toping (2054-2056):

$$2054. \int \frac{2 \sin x - \cos x}{3 \sin^2 x + 4 \cos^2 x} dx.$$

$$2055. \int \frac{(\sin x + \cos x) dx}{2 \sin^2 x - 4 \sin x \cos x + 5 \cos^2 x}.$$

$$2056. \int \frac{\sin x - 2 \cos x}{1 + 4 \sin x \cos x} dx.$$

2057. Isbotlang:

$$\int \frac{dx}{(a \sin x + b \cos x)^n} = \frac{A \sin x + B \cos x}{(a \sin x + b \cos x)^{n-1}} + C \int \frac{dx}{(a \sin x + b \cos x)^{n-2}},$$

bunda A, B, C - aniqlanma koeffitsientlar.

$$2058. \text{Toping: } \int \frac{dx}{(\sin x + 2 \cos x)^3}.$$

2059. Isbotlang:

$$\int \frac{dx}{(a + b \cos x)^n} = \frac{A \sin x}{(a + b \cos x)^{n-1}} + B \int \frac{dx}{(a + b \cos x)^{n-1}} + C \int \frac{dx}{(a + b \cos x)^{n-2}} \quad (|a| \neq |b|),$$

va n - birdan katta natural son bo'lsa, A, B, C koeffitsientlarni aniqlang.

Integrallarni toping (2060-2064):

$$2060. \int \frac{\sin x dx}{\cos x \sqrt{1 + \sin^2 x}}.$$

$$2061. \int \frac{\sin^2 x}{\cos^2 x \sqrt{\operatorname{tg} x}} dx.$$

$$2062. \int \frac{\sin x dx}{\sqrt{2 + \sin 2x}}.$$

$$2063. \int \frac{dx}{(1 + e \cos x)^2} \quad (0 < e < 1).$$

$$2064. \int \frac{\cos^{n-1} \frac{x+a}{2}}{\sin^{n+1} \frac{x-a}{2}} dx. \text{ Y o`l l a n m a. Almashtirish bajaring: } t = \frac{\cos \frac{x+a}{2}}{\sin \frac{x-a}{2}}.$$

2065. Quyidagi integral uchun pasaytirish formulasini keltirib chiqaring ($n \in N$):

$$I_n = \int \left(\frac{\sin \frac{x-a}{2}}{\sin \frac{x+a}{2}} \right)^n dx.$$

5. Turli transtendent funksiyalarni integrallash

2066. Agar $P(x)$ - n -darajali ko`phad bo`lsa, u holda quyidagini isbotlang:

$$\int P(x) e^{ax} dx = e^{ax} \left[\frac{P(x)}{a} - \frac{P'(x)}{a^2} + \dots + (1)^n \frac{P^n(x)}{a^{n+1}} \right] + C.$$

2067. Agar $P(x)$ - n -darajali ko`phad bo`lsa, u holda quyidagilarni isbotlang:

$$\int P(x) \cos ax dx = \frac{\sin ax}{a} \left[P(x) - \frac{P''(x)}{a^2} + \frac{P^{IV}(x)}{a^4} - \dots \right] + \frac{\cos ax}{a^2} \left[P'(x) - \frac{P'''(x)}{a^2} + \frac{P^V(x)}{a^4} - \dots \right] + C$$

va

$$\int P(x) \sin ax dx = -\frac{\cos ax}{a} \left[P(x) - \frac{P''(x)}{a^2} + \frac{P^{IV}(x)}{a^4} - \dots \right] + \frac{\sin ax}{a^2} \left[P'(x) - \frac{P'''(x)}{a^2} + \frac{P^V(x)}{a^4} - \dots \right] + C.$$

Integrallarni toping (2068-2080):

$$2068. \int x^3 e^{3x} dx.$$

$$2069. \int (x^2 - 2x + 2) e^{-x} dx.$$

$$2070. \int x^5 \sin 5x dx.$$

$$2071. \int (1+x^2)^2 \cos x dx.$$

$$2072. \int x^7 e^{-x^2} dx.$$

$$2073. \int x^2 e^{\sqrt{x}} dx.$$

$$2074. \int e^{ax} \cos^2 bx dx.$$

$$2075. \int e^{ax} \sin^3 bx dx.$$

$$2076. \int x e^x \sin x dx.$$

$$2077. \int x^2 e^x \cos x dx.$$

$$2078. \int x e^x \sin^2 x dx.$$

$$2079. \int (x - \sin x)^3 dx.$$

$$2080. \int \cos^2 \sqrt{x} dx.$$

2081. Agar R -ratsional funksiya va a_1, a_2, \dots, a_n sonlar o`lchovdosh bo`lsa, u holda ushbu

$$\int R(e^{a_1 x}, e^{a_2 x}, \dots, e^{a_n x}) dx$$

integral elementar funksiya ekanligini isbotlang.

Quyidagi integrallarni toping (2082-2090):

$$2082. \int \frac{dx}{(1+e^x)^2}.$$

$$2083. \int \frac{e^{2x}}{1+e^x} dx.$$

$$2084. \int \frac{dx}{e^{2x} + e^x - 2}.$$

$$2085. \int \frac{dx}{1 + e^{x/2} + e^{x/3} + e^{x/6}}.$$

$$2086. \int \frac{1 + e^{x/2}}{(1 + e^{x/4})^2} dx.$$

$$2087. \int \frac{dx}{\sqrt{e^x - 1}}.$$

$$2088. \int \sqrt{\frac{e^x - 1}{e^x + 1}} dx.$$

$$2089. \int \sqrt{e^{2x} + 4e^x - 1} dx.$$

$$2090. \int \frac{dx}{\sqrt{1 + e^x} + \sqrt{1 - e^x}}.$$

2091. Agar R - maxraji faqat haqiqiy ildizlarga ega bo'lgan ratsional funksiya bo'lsa, u holda ushbu

$$\int R(x)e^{ax} dx$$

integral elementar funksiyalar va transtsendent funksiya orqali ifodalanishini isbotlang:

$$\int \frac{e^{ax}}{x} dx = li(e^{ax}) + C,$$

bunda

$$li x = \int \frac{dx}{\ln x}.$$

2092. Qanday holda ushbu

$$\int P\left(\frac{1}{x}\right)e^x dx$$

integral elementar funksiyani ifodalaydi, bunda $P\left(\frac{1}{x}\right) = a_0 + \frac{a_1}{x} + \dots + \frac{a_n}{x^n}$ va a_1, a_2, \dots, a_n - o'zgarmas sonlar?

Integrallarni toping (2093-2097):

$$2093. \int \left(1 - \frac{2}{x}\right)^2 e^x dx.$$

$$2094. \int \left(1 - \frac{1}{x}\right) e^{-x} dx.$$

$$2095. \int \frac{e^{2x}}{x^2 - 3x + 2} dx.$$

$$2096. \int \frac{xe^x}{(x+1)^2} dx.$$

$$2097. \int \frac{x^4 e^{2x}}{(x-2)^2} dx.$$

In $f(x)$, $\arctg f(x)$, $\arcsin f(x)$, $\arccos f(x)$ integral osti funksiyalardan iborat quyidagi integrallarni toping, bunda $f(x)$ - algebraik funksiya (2098-2115):

$$2098. \int \ln^n x dx \quad (n \in N).$$

$$2099. \int x^3 \ln^3 x dx.$$

$$2100. \int \left(\frac{\ln x}{x}\right)^3 dx.$$

$$2101. \int \frac{\ln \left[(x+a)^{x+a} (x+b)^{x+b} \right]}{(x+a)(x+b)} dx.$$

$$2102. \int \ln^2 \left(x + \sqrt{1+x^2} \right) dx.$$

$$2103. \int \ln \left(\sqrt{1-x} + \sqrt{1+x} \right) dx.$$

$$2104. \int \frac{\ln x}{(1+x^2)^{3/2}} dx.$$

$$2105. \int x \arctg(x+1) dx.$$

$$2106. \int \sqrt{x} \arctg \sqrt{x} dx.$$

$$2107. \int x \arcsin(1-x) dx.$$

2108. $\int \arcsin \sqrt{x} dx.$

2110. $\int \arcsin \frac{2\sqrt{x}}{1+x} dx.$

2112. $\int \frac{x \arccos x}{(1-x^2)^{3/2}} dx.$

2114. $\int x \ln \frac{1+x}{1-x} dx.$

2109. $\int x \arccos \frac{1}{x} dx.$

2111. $\int \frac{\arccos x}{(1-x^2)^{3/2}} dx.$

2113. $\int x \operatorname{arctg} x \ln(1+x^2) dx.$

2115. $\int \frac{\ln(x + \sqrt{1+x^2}) dx}{(1+x^2)^{3/2}}.$

Giperbolik funksiyalardan iborat integrallarni toping (2116-2125):

2116. $\int \operatorname{sh}^2 x \operatorname{ch}^2 x dx.$

2118. $\int \operatorname{sh}^3 x dx.$

2120. $\int \operatorname{th} x dx.$

2122. $\int \sqrt{\operatorname{th} x} dx.$

2123.1. $\frac{dx}{\operatorname{sh}^2 x - 4 \operatorname{sh} x \operatorname{ch} x + 9 \operatorname{ch}^2 x}.$

2123.3. $\int \frac{\operatorname{ch} x dx}{3 \operatorname{sh} x - 4 \operatorname{ch} x}.$

2125. $\int \operatorname{sh} ax \cos bx dx.$

2117. $\int \operatorname{ch}^4 x dx.$

2119. $\int \operatorname{sh} x \operatorname{sh} 2x \operatorname{sh} 3x dx.$

2121. $\int \operatorname{cth}^2 x dx.$

2123. $\int \frac{dx}{\operatorname{sh} x + 2 \operatorname{ch} x}.$

2123.2. $\int \frac{dx}{0,1 + \operatorname{ch} x}.$

2124. $\int \operatorname{sh} ax \sin bx dx.$

6. Funksiyalarni integrallashga turli misollar

Integrallarni toping (2126-2175):

2126. $\int \frac{dx}{x^6(1+x^2)}.$

2128. $\int \frac{dx}{1+x^4+x^8}.$

2130. $\int x^2 \sqrt{\frac{x}{1-x}} dx.$

2132. $\int \sqrt{\frac{x}{1-x\sqrt{x}}} dx.$

2134. $\int \frac{dx}{\sqrt[3]{x^2(1-x)}}.$

2136. $\int \frac{dx}{x\sqrt{x^4-2x^2-1}}.$

2138. $\int \frac{(1+x) dx}{1+\sqrt{x+x^2}}.$

2140. $\int (2x+3) \arccos(2x-3) dx.$

2127. $\int \frac{x^2 dx}{(1-x^2)^3}.$

2129. $\int \frac{dx}{\sqrt{x} + \sqrt[3]{x}}.$

2131. $\int \frac{x+2}{x^2 \sqrt{1-x^2}} dx.$

2133. $\int \frac{x^5 dx}{\sqrt{1+x^2}}.$

2135. $\int \frac{dx}{x\sqrt{1+x^3+x^6}}.$

2137. $\int \frac{1+\sqrt{1-x^2}}{1-\sqrt{1-x^2}} dx.$

2139. $\int \frac{\ln(1+x+x^2)}{(1+x)^2} dx.$

2141. $\int x \ln(4+x^4) dx.$

2142. $\int \frac{\arcsin x}{x^2} \cdot \frac{1+x^2}{\sqrt{1-x^2}} dx.$
2144. $\int x\sqrt{x^2+1} \ln \sqrt{x^2-1} dx.$
2146. $\int \frac{dx}{(2+\sin x)^2}.$
2148. $\int \frac{dx}{\sin x \sqrt{1+\cos x}}.$
2150. $\int \frac{ax^2+b}{x^2-1} \ln \left| \frac{x-1}{x+1} \right| dx.$
2152. $\int \frac{x \operatorname{arctg} x}{\sqrt{1+x^2}} dx.$
2154. $\int \frac{x^3 \arccos x}{\sqrt{1-x^2}} dx.$
2156. $\int \frac{x \operatorname{arctg} x}{(1+x^2)^2} dx.$
2158. $\int \sqrt{1-x^2} \arcsin x dx.$
2160. $\int x^x (1+\ln x) dx.$
2162. $\int \frac{\operatorname{arctg} e^{x/2}}{e^{x/2} (1+e^x)} dx.$
2164. $\int \sqrt{th^2 x + 1} dx.$
2166. $\int |x| dx.$
2168. $\int (x+|x|)^2 dx.$
2170. $\int e^{-|x|} dx.$
2172. $\int j(x) dx$, bunda $j(x) - x$ sondan eng yaqin butun songacha bo`lgan masofa.
2173. $\int [x] |\sin px| dx$ ($x \geq 0$).
2174. $\int f(x) dx$, bunda $f(x) = \begin{cases} 1-x^2, & |x| \leq 1; \\ 1-|x|, & |x| > 1. \end{cases}$
2175. $\int f(x) dx$, bunda $f(x) = \begin{cases} 1, & \text{agap } -\infty < x < 0; \\ x+1, & \text{agap } 0 \leq x \leq 1; \\ 2x, & \text{agap } 1 < x < +\infty. \end{cases}$
2176. $\int x f''(x) dx$ integralni toping.
2177. $\int f'(2x) dx$ integralni toping.
2143. $\int \frac{x \ln(1+\sqrt{1+x^2})}{\sqrt{1+x^2}} dx.$
2145. $\int \frac{x}{\sqrt{1-x^2}} \ln \frac{x}{\sqrt{1-x}} dx.$
2147. $\int \frac{\sin 4x}{\sin^8 x + \cos^8 x} dx.$
2149. $\int \frac{ax^2+b}{x^2+1} \operatorname{arctg} x dx.$
2151. $\int \frac{x \ln x}{(1+x^2)^2} dx.$
2153. $\int \frac{\sin 2x}{\sqrt{1+\cos^4 x}} dx.$
2155. $\int \frac{x^4 \operatorname{arctg} x}{1+x^2} dx.$
2157. $\int \frac{x \ln(x+\sqrt{1+x^2})}{(1-x^2)^2} dx.$
2159. $\int x(1+x^2) \operatorname{arctg} x dx.$
2161. $\int \frac{\arcsin e^x}{e^x} dx.$
2163. $\int \frac{dx}{(e^{x+1}+1)^2 - (e^{x-1}+1)^2}.$
2165. $\int \frac{1+\sin x}{1+\cos x} \cdot e^x dx.$
2167. $\int x|x| dx.$
2169. $\int \{|1+x| - |1-x|\} dx.$
2171. $\int \max(1, x^2) dx.$

2178. Agar $f'(x^2) = \frac{1}{x}$ ($x > 0$) bo'lsa, $f(x)$ ni toping.

2179. Agar $f'(\sin^2 x) = \cos^2 x$ bo'lsa, $f(x)$ ni toping.

2180. Agar

$$f'(\ln x) = \begin{cases} 1, & 0 < x \leq 1; \\ x, & 1 < x < +\infty \end{cases} \quad \text{va} \quad f(0) = 0$$

bo'lsa, $f(x)$ ni toping.

2180.1. $f(x)$ – monoton uzluksiz funksiya va $f^{-1}(x)$ – unga teskari funksiya bo'lsin. Agar

$$\int f(x) dx = F(x) + C$$

bo'lsa, u holda

$$\int f^{-1}(x) dx = xf^{-1}(x) - F(f^{-1}(x)) + C$$

tenglikni isbotlang.

Misollar ko'ring:

a) $f(x) = x^n$ ($n > 0$); b) $f(x) = e^x$; v) $f(x) = \arcsin x$; g) $f(x) = \text{Arth } x$.

IV BO`LIM ANIQ INTEGRAL

1. Aniq integral yig`indining limiti sifatida

2181. $f(x) = 1 + x$ funksiya uchun $[-1, 4]$ kesmani n ta teng oraliqqa bo`lib va x_i argument qiymatlarini ($i = \overline{0, n-1}$) shu oraliq o`rtasidan tanlab S_n integral yig`indini toping.

2182. $f(x)$ uchun berilgan kesmalarni n ta teng bo`lakka bo`lib, \underline{S}_n va \overline{S}_n larni toping.

a) $f(x) = x^3$, $-2 \leq x \leq 3$; b) $f(x) = \sqrt{x}$, $0 \leq x \leq 1$; v) $f(x) = 2^x$, $0 \leq x \leq 10$.

2183. $f(x) = x^4$ funksiya uchun $[1, 2]$ kesmani uzunliklari geometrik progressiyani tashkil etuvchi n ta bo`lakka bo`lib, quyi integral yig`indini toping. $n \rightarrow \infty$ da bu yig`indining limiti nimaga teng?

2184. Integralning ta`rifiga ko`ra ushbu

$$\int_0^T (v_0 + gt) dt$$

integralni toping, bunda v_0 va g - o`zgarmas sonlar.

Quyidagi aniq integrallarni ta`rifdan foydalanib hisoblang (2185-2191):

2185. $\int_{-1}^2 x^2 dx$.

2186. $\int_0^1 a^x dx$ ($a > 0$).

2187. $\int_0^{\frac{x}{2}} \sin x dx$.

2188. $\int_0^x \cos t dt$.

2189. $\int_a^b \frac{dx}{x^2}$, $0 < a < b$.

Y o` l l a n m a. $x_i = \sqrt{x_i x_{i+1}}$ ($i = \overline{0, n}$) deb oling.

2190. $\int_a^b x^m dx$, $0 < a < b$, $m \neq -1$.

Y o` l l a n m a. Bo`linish nuqtalarini shunday olingki, ularning x_i abstsissalari geometrik progressiyani tashkil etsin.

2191. $\int_a^b \frac{dx}{x}$, $0 < a < b$.

2192. Ushbu

$$\int_0^p \ln(1 - 2a \cos x + a^2) dx$$

Puasson integralini a) $|a| < 1$; b) $|a| > 1$ bo`lganda hisoblang.

Y o` l l a n m a. $a^{2n} - 1$ ko`phadning kvadratik ko`paytuvchilarga yoyilmasidan foydalaning.

2193. $f(x)$ va $j(x)$ funksiyalar $[a, b]$ kesmada uzluksiz bo`lsin. U holda ushbu

$$\lim_{\max|\Delta x_i| \rightarrow 0} \sum_{i=0}^{n-1} f(x_i) j(q_i) \Delta x_i = \int_a^b f(x) j(x) dx$$

tenglikni isbotlang, bunda $x_i \leq x_i \leq x_{i+1}$, $x_i \leq q_i \leq x_{i+1}$ ($i = 0, 1, \dots, n-1$) va $\Delta x_i = x_{i+1} - x_i$ ($x_0 = a, x_n = b$).

2193.1. $f(x)$ funksiya $[0, 1]$ kesmada monoton va chegaralangan bo'lsin. Quyidagi tenglikni isbotlang:

$$\int_0^1 f(x) dx - \frac{1}{n} \sum_{k=1}^n f\left(\frac{k}{n}\right) = O\left(\frac{1}{n}\right).$$

2193.2. $f(x)$ funksiya $[a, b]$ kesmada chegaralangan va yuqoridan qavariq bo'lsin. U holda quyidagini isbotlang:

$$(b-a) \frac{f(a) + f(b)}{2} \leq \int_a^b f(x) dx \leq (b-a) f\left(\frac{a+b}{2}\right).$$

2193.3. $f(x) \in C^{(2)}[1, +\infty]$ va $x \in [1, +\infty]$ da $f(x) \geq 0$, $f'(x) \geq 0$, $f''(x) \leq 0$ bo'lsin. U holda $n \rightarrow \infty$ da quyidagi tenglikni isbotlang:

$$\sum_{k=1}^n f(k) = \frac{1}{2} f(n) + \int_1^n f(x) dx + O(1).$$

2193.4. $f(x) \in C^{(1)}[a, b]$ va

$$\Delta_n = \int_a^b f(x) dx - \frac{b-a}{n} \sum_{k=1}^n f\left(a + k \cdot \frac{b-a}{n}\right)$$

bo'lsin. $\lim_{n \rightarrow \infty} n \Delta_n$ limitni toping.

2194. Ushbu

$$f(x) = \operatorname{sgn}\left(\sin \frac{p}{x}\right)$$

uzilishga ega funksiya $[0, 1]$ kesmada integrallanuvchi ekanligini isbotlang.

2195. Ushbu

$$j(x) = \begin{cases} 0, & \text{agar } x \text{ irracional b'ulsa;} \\ \frac{1}{n}, & \text{agar } x = \frac{m}{n} \text{ b'ulsa} \end{cases}$$

Riman funksiyasi ixtiyoriy chekli oraliqda integrallanuvchi ekanligini isbotlang, bunda m va n ($n \geq 1$)- o'zaro tub butun sonlar.

2196. $x \neq 0$ da

$$f(x) = \frac{1}{x} - \left[\frac{1}{x} \right]$$

va $f(0) = 0$ funksiya $[0, 1]$ kesmada integrallanuvchi ekanligini isbotlang.

2197. Ushbu

$$c(x) = \begin{cases} 0, & x \text{ irracional b'ulsa;} \\ 1, & x - \text{rational b'ulsa} \end{cases}$$

Dirixle funksiyasi ixtiyoriy oraliqda integrallanuvchi emasligini isbotlang.

2198. $f(x)$ funksiya $[a, b]$ kesmada integrallanuvchi va $x_i \leq x < x_{i+1}$ da

$$f_n(x) = \sup f(x)$$

bo'lsin, bunda

$$x_i = a + \frac{i}{n}(b-a) \quad (i = 0, 1, \dots, n; \quad n = 1, 2, \dots).$$

Quyidagi tenglikni isbotlang:

$$\lim_{n \rightarrow \infty} \int_a^b f_n(x) dx = \int_a^b f(x) dx.$$

2199. Agar $f(x)$ funksiya $[a, b]$ kesmada integrallanuvchi bo`lsa, u holda shunday uzluksiz $j_n(x)$ ($n = 1, 2, \dots$) funksiyalar ketma-ketligi mavjudki, $a \leq c \leq b$ da ushbu

$$\int_a^c f(x) dx = \lim_{n \rightarrow \infty} \int_a^c j_n(x) dx$$

tenglik o`rinli bo`ladi. Isbotlang.

2200. Agar chegaralangan $f(x)$ funksiya $[a, b]$ kesmada integrallanuvchi bo`lsa, u holda $|f(x)|$ funksiya ham $[a, b]$ kesmada integrallanuvchi va

$$\left| \int_a^b f(x) dx \right| \leq \int_a^b |f(x)| dx$$

tenglik o`rinli bo`lishini isbotlang.

2201. $f(x)$ funksiya $[a, b]$ kesmada absolyut integrallanuvchi bo`lsin, ya`ni $\int_a^b |f(x)| dx$ integral mavjud. Bu funksiya $[a, b]$ kesmada integrallanuvchi bo`ladimi?

Misol ko`ring: $f(x) = \begin{cases} 1, & \text{agar } x \text{ raatsional b} \ddot{u} \text{lsa;} \\ -1, & \text{agar } x \text{ irraatsional b} \ddot{u} \text{lsa.} \end{cases}$

2202. $f(x)$ funksiya $[a, b]$ kesmada integrallanuvchi va $a \leq x \leq b$ da $A \leq f(x) \leq B$, $j(x)$ funksiya esa $[A, B]$ kesmada aniqlangan va uzluksiz bo`lsin. U holda $j(f(x))$ funksiya ham $[a, b]$ kesmada integrallanuvchi bo`lishini isbotlang.

2203. Agar $f(x)$ va $j(x)$ funksiyalar integrallanuvchi bo`lsa, u holda $f(j(x))$ funksiya ham albatta integrallanuvchi bo`ladimi?

Misol ko`ring: $f(x) = \begin{cases} 0, & \text{agar } x = 0; \\ 1, & \text{agar } x \neq 0. \end{cases}$

2204. $f(x)$ funksiya $[A, B]$ kesmada integrallanuvchi bo`lsin. U holda $f(x)$ funksiya integral uzluksizlik xossasiga ega ekanligini isbotlang, ya`ni

$$\lim_{h \rightarrow 0} \int_a^b |f(x+h) - f(x)| dx = 0,$$

bunda $[a, b] \subset [A, B]$.

2205. $f(x)$ funksiya $[a, b]$ kesmada integrallanuvchi bo`lsin. U holda ushbu

$$\int_a^b f^2(x) dx = 0$$

tenglik bajarilishi uchun $f(x)$ funksiyaning $[a, b]$ kesmaga tegishli barcha uzluksizlik nuqtalarida $f(x) = 0$ bo`lishi zarur va etarli ekanligini isbotlang.

2. Aniq integrallarni aniqmas integrallar yordamida hisoblash

N'yuton-Leybnits formulasidan foydalanib quyidagi aniq integrallarni hisoblang va mos egri chiziqli yuzalarni chizing (2206-2215):

$$2206. \int_{-1}^8 \sqrt[3]{x} dx.$$

$$2207. \int_0^p \sin x dx.$$

$$2208. \int_{\frac{1}{\sqrt{3}}}^{\sqrt{3}} \frac{dx}{1+x^2}.$$

$$2209. \int_{-\frac{1}{2}}^{\frac{1}{2}} \frac{dx}{\sqrt{1-x^2}}.$$

$$2210. \int_{sh1}^{sh2} \frac{dx}{\sqrt{1+x^2}}.$$

$$2211. \int_0^2 |1-x| dx.$$

$$2212. \int_{-1}^1 \frac{dx}{x^2 - 2x \cos a + 1} \quad (0 < a < p).$$

$$2213. \int_0^{2p} \frac{dx}{1+e \cos x} \quad (0 \leq e < 1).$$

$$2214. \int_{-1}^1 \frac{dx}{\sqrt{(1-2ax+a^2)(1-2bx+b^2)}} \quad (|a| < 1, |b| < 1, ab > 0).$$

$$2215. \int_0^{\frac{p}{2}} \frac{dx}{a^2 \sin^2 x + b^2 \cos^2 x} \quad (ab \neq 0).$$

2216. Quyidagi integrallarda nima uchun N'yuton-Leybnits formulasining formal tatbig'i noto'g'ri natijalarga olib kelishini tushuntiring:

$$a) \int_{-1}^1 \frac{dx}{x};$$

$$b) \int_0^{2p} \frac{\sec^2 x}{2+tg^2 x} dx;$$

$$v) \int_{-1}^1 \frac{d}{dx} \left(\arctg \frac{1}{x} \right) dx.$$

$$2217. \text{Hisoblang: } \int_{-1}^1 \frac{d}{dx} \left(\frac{1}{1+2^{\frac{1}{x}}} \right) dx.$$

$$2218. \text{Hisoblang: } \int_0^{100p} \sqrt{1-\cos 2x} dx.$$

Aniq integrallar yordamida quyidagi yig'indilarning limitlarini hisoblang (2219-2224):

$$2219. \lim_{n \rightarrow \infty} \left(\frac{1}{n^2} + \frac{2}{n^2} + \dots + \frac{n-1}{n^2} \right).$$

$$2220. \lim_{n \rightarrow \infty} \left(\frac{1}{n+1} + \frac{1}{n+2} + \dots + \frac{1}{n+n} \right).$$

$$2221. \lim_{n \rightarrow \infty} \left(\frac{n}{n^2+1^2} + \frac{n}{n^2+2^2} + \dots + \frac{n}{n^2+n^2} \right).$$

$$2222. \lim_{n \rightarrow \infty} \frac{1}{n} \left(\sin \frac{p}{n} + \sin \frac{2p}{n} + \dots + \sin \frac{(n-1)p}{n} \right). \quad 2223. \lim_{n \rightarrow \infty} \frac{1^p + 2^p + \dots + n^p}{n^{p+1}} \quad (p > 0).$$

$$2224. \lim_{n \rightarrow \infty} \frac{1}{n} \left(\sqrt{1+\frac{1}{n}} + \sqrt{1+\frac{2}{n}} + \dots + \sqrt{1+\frac{n}{n}} \right).$$

Toping:

$$2225. \lim_{n \rightarrow \infty} \frac{\sqrt[n]{n!}}{n}.$$

$$2226. \lim_{n \rightarrow \infty} \left[\frac{1}{n} \sum_{k=1}^n f \left(a + k \frac{b-a}{n} \right) \right].$$

YUqori tartibli cheksiz kichik miqdorlarni tekis tashlab yuborib, quyidagi yig'indilarning limitlarini toping (2227-2230):

$$2227. \lim_{n \rightarrow \infty} \left[\left(1 + \frac{1}{n}\right) \sin \frac{p}{n^2} + \left(1 + \frac{2}{n}\right) \sin \frac{2p}{n^2} + \dots + \left(1 + \frac{n-1}{n}\right) \sin \frac{(n-1)p}{n^2} \right].$$

$$2228. \lim_{n \rightarrow \infty} \sin \frac{p}{n} \sum_{k=1}^n \frac{1}{2 + \cos \frac{kp}{n}}.$$

$$2229. \lim_{n \rightarrow \infty} \frac{\sum_{k=1}^n \sqrt{(nx+k)(nx+k+1)}}{n^2} \quad (x > 0).$$

$$2230. \lim_{n \rightarrow \infty} \left(\frac{2^{\frac{1}{n}}}{n+1} + \frac{2^{\frac{2}{n}}}{n+\frac{1}{2}} + \dots + \frac{2^{\frac{n}{n}}}{n+\frac{1}{n}} \right).$$

2231. Topping:

$$\frac{d}{dx} \int_a^b \sin x^2 dx,$$

$$\frac{d}{da} \int_a^b \sin x^2 dx,$$

$$\frac{d}{db} \int_a^b \sin x^2 dx.$$

2232. Topping:

$$a) \frac{d}{dx} \int_0^{x^2} \sqrt{1+t^2} dt;$$

$$b) \frac{d}{dx} \int_{x^2}^{x^3} \frac{dt}{\sqrt{1+t^4}};$$

$$v) \frac{d}{dx} \int_{\sin x}^{\cos x} \cos(pt^2) dt.$$

2233. Topping:

$$a) \lim_{x \rightarrow 0} \frac{\int_0^x \cos x^2 dx}{x};$$

$$b) \lim_{x \rightarrow +\infty} \frac{\int_0^x (\arctg x)^2 dx}{\sqrt{x^2+1}};$$

$$v) \lim_{x \rightarrow +\infty} \frac{\left(\int_0^x e^{x^2} dx \right)^2}{\int_0^x e^{2x^2} dx}$$

2233.1. $f(x) \in C[0, +\infty]$ va $x \rightarrow +\infty$ da $f(x) \rightarrow A$ bo'lsin. $\lim_{n \rightarrow \infty} \int_0^1 f(nx) dx$ ni toping.

2234. $x \rightarrow \infty$ da $\int_0^x e^{x^2} dx : \frac{1}{2x} e^{x^2}$ bo'lishini isbotlang.

$$2235. \text{Hisoblang: } \lim_{x \rightarrow +0} \frac{\int_0^{\sin x} \sqrt{\operatorname{tg} x} dx}{\int_0^{\operatorname{tg} x} \sqrt{\sin x} dx}.$$

2236. $f(x)$ – uzluksiz musbat funksiya bo'lsin. U holda ushbu

$$j(x) = \frac{\int_0^x tf(t) dt}{\int_0^x f(t) dt}$$

funksiya $x \geq 0$ da o'suvchi ekanligini isbotlang.

2237. Topping:

$$a) \int_0^2 f(x) dx, \text{ bunda } f(x) = \begin{cases} x^2, & 0 \leq x \leq 1, \\ 2-x, & 1 < x \leq 2; \end{cases}$$

$$b) \int_0^1 f(x) dx, \text{ bunda } f(x) = \begin{cases} x, & 0 \leq x \leq t, \\ t \cdot \frac{1-x}{1-t}, & t \leq x \leq 1. \end{cases}$$

2238. $I = I(a)$ integrallarni a parametrning funksiyasi sifatida qarab hisoblang va grafiklarini yasang:

$$a) I = \int_0^1 x|x-a| dx; \quad b) I = \int_0^p \frac{\sin^2 x}{1+2a \cos x + a^2} dx; \quad v) I = \int_0^p \frac{\sin x dx}{\sqrt{1-2a \cos x + a^2}}.$$

Bo'laklab integrallash usuli yordamida quyidagi aniq integrallarni toping (2239-2244):

$$2239. \int_0^{\ln 2} x e^{-x} dx.$$

$$2240. \int_0^p x \sin x dx.$$

$$2241. \int_0^{2p} x^2 \cos x dx.$$

$$2242. \int_{\frac{1}{e}}^e |\ln x| dx.$$

$$2243. \int_0^1 \arccos x dx.$$

$$2244. \int_0^{\sqrt{3}} x \operatorname{arctg} x dx.$$

Quyidagi aniq integrallarni o'zgaruvchini mos ravishda almashtirib toping (2245-2249):

$$2245. \int_{-1}^1 \frac{x dx}{\sqrt{5-4x}}.$$

$$2246. \int_0^a x^2 \sqrt{a^2 - x^2} dx.$$

$$2247. \int_0^{0.75} \frac{dx}{(x+1)\sqrt{x^2+1}}.$$

$$2248. \int_0^{\ln 2} \sqrt{e^x - 1} dx.$$

$$2249. \int_0^1 \frac{\arcsin \sqrt{x}}{\sqrt{x(1-x)}} dx.$$

$$2250. x - \frac{1}{x} = t \text{ deb olib integralni hisoblang: } \int_{-1}^1 \frac{1+x^2}{1+x^4} dx.$$

2251. Quyidagi integrallarda nima uchun $x = j(t)$ formal almashtirish noto'g'ri natijalarga olib kelishini tushuntiring:

$$a) \int_{-1}^1 dx, t = x^{\frac{2}{3}}; \quad b) \int_{-1}^1 \frac{dx}{1+x^2}, x = \frac{1}{t}; \quad v) \int_0^p \frac{dx}{1+\sin^2 x}, \operatorname{tg} x = t.$$

$$2252. \int_0^3 x^3 \sqrt{1-x^2} dx \text{ integralda } x = \sin t \text{ deb olish mumkinmi?}$$

$$2253. \int_0^1 \sqrt{1-x^2} dx \text{ integralda } x = \sin t \text{ almashtirish bajarilganda } t \text{ yangi o'zgaruvchining}$$

chegaralari sifatida p va $\frac{p}{2}$ sonlarni olish mumkinmi?

2254. Agar $f(x)$ funksiya $[a, b]$ kesmada uzluksiz bo'lsa, u holda

$$\int_a^b f(x) dx = (b-a) \int_0^1 f(a+(b-a)x) dx$$

tenglik o'rinli bo'lishini isbotlang.

$$2255. \text{ Tenglikni isbotlang: } \int_0^a x^3 f(x^2) dx = \frac{1}{2} \int_0^{a^2} x f(x) dx \quad (a > 0).$$

2256. $f(x)$ funksiya $[A, B] \supset [a, b]$ kesmada uzluksiz bo`lsin. U holda $[a-x, b-x] \subset [A, B]$ da $\frac{d}{dx} \int_a^b f(x+y) dy$ ni toping.

2257. Agar $f(x)$ funksiya $[0, 1]$ kesmada uzluksiz bo`lsa, u holda quyidagi tengliklarni isbotlang:

$$\text{a) } \int_0^{\frac{p}{2}} f(\sin x) dx = \int_0^{\frac{p}{2}} f(\cos x) dx; \quad \text{b) } \int_0^p x f(\sin x) dx = \frac{p}{2} \int_0^p f(\sin x) dx.$$

2258. $[-l, l]$ kesmada uzluksiz $f(x)$ funksiya uchun agar $f(x)$ juft funksiya bo`lsa, u holda $\int_{-l}^l f(x) dx = 2 \int_0^l f(x) dx$, va agar $f(x)$ toq funksiya bo`lsa, $\int_{-l}^l f(x) dx = 0$ tenglik o`rinli bo`lishini isbotlang. Bu tasdiqlarning geometrik interpretatsiyasini bering.

2259. Juft funksiyaning boshlang`ich funksiyalaridan biri toq funksiya, toq funksiyaning ixtiyoriy boshlang`ich funksiyasi esa toq funksiya ekanligini isbotlang.

2260. Ushbu

$$\int_{\frac{1}{2}}^2 \left(1 + x - \frac{1}{x}\right) e^{x+\frac{1}{x}} dx$$

integralni quyidagicha yangi o`zgaruvchi kiritib hisoblang:

$$t = x + \frac{1}{x}.$$

2261. $\int_0^{2p} f(x) \cos x dx$ integralda o`zgaruvchini $\sin x = t$ kabi almashtiring.

2262. Hisoblang: $\int_{e^{-2pn}}^1 \left[\cos \left(\ln \frac{1}{x} \right) \right] dx, (n \in \mathbb{N}).$

2263. Hisoblang: $\int_0^p \frac{\sin x}{1 + \cos^2 x} dx.$

2264. Agar $f(x) = \frac{(x+1)^2(x-1)}{x^3(x-2)}$ bo`lsa, quyidagi integralni hisoblang:

$$\int_{-1}^3 \frac{f'(x)}{1 + f^2(x)} dx.$$

2265. Agar $f(x)$ funksiya $-\infty < x < +\infty$ oraliqda aniqlangan, uzluksiz va T davrga ega davriy funksiya bo`lsa, u holda ushbu

$$\int_a^{a+T} f(x) dx = \int_0^T f(x) dx$$

tenglik o`rinli ekanligini isbotlang, bunda a - ixtiyoriy son.

2266. $F(x) = \int_0^x \sin^n x dx$ va $G(x) = \int_0^x \cos^n x dx$ funksiyalar n ning toq qiymatlarida $2p$

davrga ega davriy funksiyalar, n ning juft qiymatlarida esa ularning har biri chiziqli va davriy funksiyalarning yig`indisi ekanligini isbotlang.

2267. Agar $f(x)$ - uzluksiz T davrga ega davriy funksiya bo`lsa, u holda ushbu

$$F(x) = \int_{x_0}^x f(x) dx$$

funksiya, umumiy holda, chiziqli va T davrga ega davriy funksiyalarning yig'indisidan iborat ekanligini isbotlang.

Integrallarni hisoblang (2268-2280):

$$2268. \int_0^1 x(2-x^2)^{12} dx.$$

$$2269. \int_{-1}^1 \frac{x dx}{x^2 + x + 1}.$$

$$2270. \int_1^e (x \ln x)^2 dx.$$

$$2271. \int_1^2 x^3 \sqrt{1-x} dx.$$

$$2272. \int_{-2}^{-1} \frac{dx}{x\sqrt{x^2-1}}.$$

$$2273. \int_0^1 x^{15} \sqrt{1+3x^8} dx.$$

$$2274. \int_0^3 \arcsin \sqrt{\frac{x}{1+x}} dx.$$

$$2275. \int_0^{2p} \frac{dx}{(2+\cos x)(3+\cos x)}.$$

$$2276. \int_0^{2p} \frac{dx}{\sin^4 x + \cos^4 x}.$$

$$2277. \int_0^{\frac{p}{2}} \sin x \sin 2x \sin 3x dx.$$

$$2278. \int_0^p (x \sin x)^2 dx.$$

$$2279. \int_0^p e^x \cos^2 x dx.$$

$$2280. \int_0^{\ln 2} sh^4 x dx.$$

n parametrga bog'liq bo'lgan quyidagi integrallarni darajani pasaytirish formulalaridan foydalanib hisoblang (n – butun musbat son, 2281-2287):

$$2281. I_n = \int_0^{\frac{p}{2}} \sin^n x dx.$$

$$2282. I_n = \int_0^{\frac{p}{2}} \cos^n x dx.$$

$$2283. I_n = \int_0^{\frac{p}{4}} tg^{2n} x dx.$$

$$2284. I_n = \int_0^1 (1-x^2)^n dx.$$

$$2285. I_n = \int_0^1 \frac{x^n dx}{\sqrt{1-x^2}}.$$

$$2286. I_n = \int_0^1 x^m (\ln x)^n dx.$$

$$2287. I_n = \int_0^{\frac{p}{4}} \left(\frac{\sin x - \cos x}{\sin x + \cos x} \right)^{2n+1} dx.$$

Agar $f(x) = f_1(x) + if_2(x)$ funksiya haqiqiy x o'zgaruvchili kompleks funksiya bo'lsa, bunda $f_1(x) = \operatorname{Re} f(x)$, $f_2(x) = \operatorname{Im} f(x)$ va $i^2 = -1$, u holda ta'rifga ko'ra

$$\int f(x) dx = \int f_1(x) dx + i \int f_2(x) dx$$

bo'ladi. Ushbu

$$\operatorname{Re} \int f(x) dx = \int \operatorname{Re} f(x) dx,$$

$$\operatorname{Im} \int f(x) dx = \int \operatorname{Im} f(x) dx$$

tengliklar o'z-o'zidan ravshan.

2288. Ushbu

$$e^{ix} = \cos x + i \sin x$$

Eyler formulasidan foydalanib, quyidagi tenglikni isbotlang:

$$\int_0^{2p} e^{inx} e^{-imx} dx = \begin{cases} 0, & \text{a}z\text{ap } m \neq n, \\ 2p, & \text{a}z\text{ap } m = n. \end{cases} \quad (n, m \in \mathbb{Z})$$

2289. Isbotlang: $\int_a^b e^{(a+ib)x} dx = \frac{e^{b(a+ib)} - e^{a(a+ib)}}{a+ib} \quad (a, b = \text{const}).$

Ushbu

$$\cos x = \frac{1}{2}(e^{ix} + e^{-ix}), \quad \sin x = \frac{1}{2i}(e^{ix} - e^{-ix})$$

Eyler formulalaridan foydalanib, integrallarni hisoblang (m va n – butun musbat sonlar, 2290-2294):

2290. $\int_0^{\frac{p}{2}} \sin^{2m} x \cos^{2n} x dx.$

2291. $\int_0^{\frac{p}{2}} \frac{\sin nx}{\sin x} dx.$

2292. $\int_0^{\frac{p}{2}} \frac{\cos(2n+1)x}{\cos x} dx.$

2293. $\int_0^{\frac{p}{2}} \cos^n x \cos nx dx.$

2294. $\int_0^{\frac{p}{2}} \sin^n x \sin nx dx.$

Integrallarni toping (n – natural son, 2295-2298):

2295. $\int_0^{\frac{p}{2}} \sin^{n-1} x \cos(n+1)x dx.$

2296. $\int_0^{\frac{p}{2}} \cos^{n-1} x \cos(n+1)x dx.$

2297. $\int_0^{2p} e^{-ax} \cos^{2n} x dx.$

2298. $\int_0^{\frac{p}{2}} \ln \cos x \cdot \cos 2nx dx.$

2299. Ko`p marta bo`laklab integrallash usulini qo`llab, quyidagi eyler integralini hisoblang (m va n – butun musbat sonlar):

$$B(m, n) = \int_0^1 x^{m-1} (1-x)^{n-1} dx.$$

2300. $P_n(x)$ Lejandr ko`phadi ushbu

$$P_n(x) = \frac{1}{2^n n!} \frac{d^n}{dx^n} \left[(x^2 - 1)^n \right] \quad (n = 0, 1, 2, \dots)$$

formula bilan aniqlanadi.

Isbotlang:

$$\int_{-1}^1 P_m(x) P_n(x) dx = \begin{cases} 0, & \text{a}z\text{ap } m \neq n, \\ \frac{2}{2n+1}, & \text{a}z\text{ap } m = n. \end{cases}$$

2301. $f(x)$ funksiya $[a, b]$ kesmada integrallanuvchi bo`lsin va $F(x)$ funksiya $[a, b]$ kesmaning, balkim, chekli sondagi c_i ($i = 1, \dots, p$) ichki nuqtalaridan va funksiya 1-tur uzilishga ega bo`lgan a va b nuqtalaridan tashqari barcha nuqtalarida $F'(x) = f(x)$ shartni qanoatlantirsin. U holda quyidagi tenglikni isbotlang:

$$\int_a^b f(x) dx = F(b-0) - F(a+0) - \sum_{i=1}^p [F(c_i+0) - F(c_i-0)].$$

2302. $f(x)$ funksiya $[a, b]$ kesmada integrallanuvchi va

$$F(x) = C + \int_a^x f(x) dx$$

- uning aniqmas integrali bo'lsin. $F(x)$ funksiya uzluksiz va $f(x)$ funksiyaning barcha uzluksizlik nuqtalarida

$$F'(x) = f(x)$$

tenglik o'rinli ekanligini isbotlang.

$f(x)$ funksiyaning uzilishga ega nuqtalarida $F(x)$ funksiyaning hosilasi haqida nima deyish mumkin?

Misollar ko'ring:

a) $f\left(\frac{1}{n}\right) = 1$ ($n = \pm 1, \pm 2, \dots$) va $x \neq \frac{1}{n}$ da $f(x) = 0$; b) $f(x) = \operatorname{sgn} x$.

CHegaralangan uzilishga ega funksiyalarning aniqmas integrallarini toping (2303-2308):

2303. $\int \operatorname{sgn} x dx$.

2304. $\int \operatorname{sgn}(\sin x) dx$.

2305. $\int [x] dx$ ($x \geq 0$).

2306. $\int x[x] dx$ ($x \geq 0$).

2307. $\int (-1)^{[x]} dx$.

2308. $\int_0^x f(x) dx$, bunda $f(x) = \begin{cases} 1, & \text{agar } |x| < l, \\ 0, & \text{agar } |x| > l. \end{cases}$

CHegaralangan uzilishga ega funksiyalarning aniq integrallarini toping (2309-2314):

2309. $\int_0^3 \operatorname{sgn}(x - x^3) dx$.

2310. $\int_0^2 [e^x] dx$.

2311. $\int_0^6 [x] \sin \frac{px}{6} dx$.

2312. $\int_0^p x \operatorname{sgn}(\cos x) dx$.

2313. $\int_1^{n+1} \ln [x] dx$ ($n \in \mathbb{N}$).

2314. $\int_0^1 \operatorname{sgn}[\sin(\ln x)] dx$.

2315. $\int_E |\cos x| \sqrt{\sin x} dx$ integralni hisoblang, bunda E – integral ostidagi funksiya ma'noga

ega bo'ladigan $[0, 4p]$ kesmaning qiymatlaridan iborat.

3. O'rta qiymat haqida teorema

2316. Quyidagi aniq integrallarning ishorasini aniqlang:

a) $\int_0^{2p} x \sin x dx$;

b) $\int_0^{2p} \frac{\sin x}{x} dx$;

v) $\int_{-2}^2 x^3 2^x dx$;

g) $\int_{\frac{1}{2}}^1 x^2 \ln x dx$.

2317. Qaysi integral katta:

a) $\int_0^{\frac{p}{2}} \sin^{10} x dx$ yoki $\int_0^{\frac{p}{2}} \sin^2 x dx$?

b) $\int_0^1 e^{-x} dx$ yoki $\int_0^1 e^{-x^2} dx$?

v) $\int_0^p e^{-x^2} \cos^2 x dx$ yoki $\int_p^{2p} e^{-x^2} \cos^2 x dx$?

2318. Berilgan funksiyalarning ko'rsatilgan oraliqlarda o'rta qiymatini toping:

a) $f(x) = x^2$, $[0, 1]$;

b) $f(x) = \sqrt{x}$, $[0, 100]$;

v) $f(x) = 10 + 2 \sin x + 3 \cos x$, $[0, 2p]$; g) $f(x) = \sin x \sin(x + j)$, $[0, 2p]$.

2319. ellipsning fokal radius-vektori uzunligining o`rta qiymatini toping:

$$r = \frac{p}{1 - e \cos j} \quad (0 < e < 1).$$

2320. Boshlang`ich tezligi v_0 bo`lgan yuqoridan erkin tushayotgan jism tezligining o`rta qiymatini toping.

2321. O`zgaruvchi tok kuchi ushbu

$$i = i_0 \sin\left(\frac{2pt}{T} + j\right)$$

qonun bo`yicha o`zgaradi, bunda i_0 – amplituda, t – vaqt, T – davr va j – boshlang`ich faza. Tok kuchi kvadratining o`rta qiymatini toping.

2321.1. $f(x) \in C[0, +\infty]$ va $\lim_{x \rightarrow +\infty} f(x) = A$ bo`lsin. U holda quyidagi limitni toping:

$$\lim_{x \rightarrow +\infty} \frac{1}{x} \int_0^x f(x) dx.$$

Misol ko`ring: $f(x) = \arctg x$

2322. $\int_0^x f(t) dt = xf(qx)$ tenglik o`rinli bo`lsin. Agar:

a) $f(t) = t^n$ ($n > -1$); b) $f(t) = \ln t$; v) $f(t) = e^t$

bo`lsa, q ni toping.

$\lim_{x \rightarrow +0} q$ va $\lim_{x \rightarrow +\infty} q$ lar nimaga teng?

O`rta qiymat haqida birinchi teoremdan foydalanib, integrallarni baholang:

2323. $\int_0^{2p} \frac{dx}{1 + 0,5 \cos x}$.

2324. $\int_0^1 \frac{x^9}{\sqrt{1+x}} dx$.

2325. $\int_0^{100} \frac{e^{-x}}{x+100} dx$.

2326. Tengliklarni isbotlang:

a) $\lim_{n \rightarrow \infty} \int_0^1 \frac{x^n}{1+x} dx = 0$;

b) $\lim_{n \rightarrow \infty} \int_0^{\frac{p}{2}} \sin^n x dx = 0$.

2326.1. Limitlarni toping:

a) $\lim_{e \rightarrow 0} \int_0^1 \frac{dx}{e x^3 + 1}$;

b) $\lim_{e \rightarrow +0} \int_{ae}^{be} f(x) \frac{dx}{x}$,

bunda $a > 0$, $b > 0$ va $f(x) \in C[0, 1]$.

2327. $f(x)$ funksiya $[a, b]$ kesmada uzluksiz, $j(x)$ funksiya esa $[a, b]$ kesmada uzluksiz va (a, b) intervalda differentsiallanuvchi hamda $a < x < b$ da

$$j'(x) \geq 0$$

tengsizlik o`rinli bo`lsin.

O`rta qiymat haqida ikkinchi teoremani bo`laklab integrallash usuli va o`rta qiymat haqida birinchi teoremdan foydalanib isbotlang.

O`rta qiymat haqida ikkinchi teoremdan foydalanib, integrallarni baholang:

2328. $\int_{100p}^{200p} \frac{\sin x}{x} dx$.

2329. $\int_a^b \frac{e^{-ax}}{x} \sin x dx$ ($a \geq 0$; $0 < a < b$).

$$2330. \int_a^b \sin x^2 dx \quad (0 < a < b).$$

2331. $j(x)$ va $y(x)$ funksiyalar kvadratlari bilan birga $[a, b]$ kesmada integrallanuvchi bo'lsin. U holda quyidagi Koshi-Bunyakovskiy tengsizligini isbotlang:

$$\left\{ \int_a^b j(x)y(x) dx \right\}^2 \leq \int_a^b j^2(x) dx \int_a^b y^2(x) dx.$$

2332. $f(x)$ funksiya $[a, b]$ kesmada uzluksiz differentsiallanuvchi va $f(a) = 0$ bo'lsin. U holda quyidagi tengsizlikni isbotlang:

$$M^2 \leq (b-a) \int_a^b f'^2(x) dx,$$

bunda $M = \sup_{a \leq x \leq b} |f(x)|$.

2333. Tenglikni isbotlang:

$$\lim_{n \rightarrow \infty} \int_n^{n+p} \frac{\sin x}{x} dx = 0 \quad (p > 0).$$

4. Xosmas integrallar

Integrallarni hisoblang (2334-2347):

$$2334. \int_a^{-\infty} \frac{dx}{x^2} \quad (a > 0).$$

$$2335. \int_0^1 \ln x dx.$$

$$2336. \int_{-\infty}^{+\infty} \frac{dx}{1+x^2}.$$

$$2337. \int_{-1}^1 \frac{dx}{\sqrt{1-x^2}}.$$

$$2338. \int_2^{+\infty} \frac{dx}{x^2+x-2}.$$

$$2339. \int_{-\infty}^{+\infty} \frac{dx}{(x^2+x+1)^2}.$$

$$2340. \int_0^{+\infty} \frac{dx}{1+x^3}.$$

$$2341. \int_0^{+\infty} \frac{x^2+1}{x^4+1} dx.$$

$$2342. \int_0^1 \frac{dx}{(2-x)\sqrt{1-x}}.$$

$$2343. \int_1^{+\infty} \frac{dx}{x\sqrt{1+x^5+x^{10}}}.$$

$$2344. \int_0^{+\infty} \frac{x \ln x}{(1+x^2)^2} dx.$$

$$2345. \int_0^{+\infty} \frac{\operatorname{arctg} x}{(1+x^2)^{3/2}} dx.$$

$$2346. \int_0^{+\infty} e^{-ax} \cos bx dx \quad (a > 0).$$

$$2347. \int_0^{+\infty} e^{-ax} \sin bx dx \quad (a > 0).$$

Darajani pasaytirish formulalaridan foydalanib, quyidagi xosmas integrallarni hisoblang ($n \in N$):

$$2348. I_n = \int_0^{+\infty} x^n e^{-x} dx.$$

$$2349. I_n = \int_{-\infty}^{+\infty} \frac{dx}{(ax^2+2bx+c)^n} \quad (ac-b^2 > 0).$$

$$2350. I_n = \int_1^{+\infty} \frac{dx}{x(x+1)\dots(x+n)}.$$

$$2351. I_n = \int_0^1 \frac{x^n dx}{\sqrt{(1-x)(1+x)}}.$$

$$2352. I_n = \int_0^{+\infty} \frac{dx}{ch^{n+1}x}.$$

$$2353. \text{ a) } \int_0^{p/2} \ln \sin x dx;$$

$$\text{ b) } \int_0^{p/2} \ln \cos x dx.$$

$$2354. \int_E e^{-\frac{x}{2}} \frac{|\sin x - \cos x|}{\sqrt{\sin x}} dx \text{ integralni toping, bunda } E - \text{ integral ostidagi funksiya ma`noga}$$

ega bo`ladigan $(0, +\infty)$ intervalning x qiymatlari to`plamidan iborat.

2355. CHap tomondagi integral ma`noga ega deb faraz qilib, tenglikni isbotlang:

$$\int_0^{+\infty} f\left(ax + \frac{b}{x}\right) dx = \frac{1}{a} \int_0^{+\infty} f\left(\sqrt{x^2 + 4ab}\right) dx,$$

bunda $a > 0$ va $b > 0$.

2356. $f(x)$ funksiyaning $(0, +\infty)$ oraliqdagi o`rta qiymati deb ushbu

$$M|f| = \lim_{x \rightarrow +\infty} \frac{1}{x} \int_0^x f(x) dx$$

songa aytiladi.

Quyidagi funksiyalarning o`rta qiymatini toping:

$$\text{ a) } f(x) = \sin^2 x + \cos^2(x\sqrt{2}); \quad \text{ b) } f(x) = \arctg x; \quad \text{ v) } f(x) = \sqrt{x} \sin x.$$

2357. Toping:

$$\text{ a) } \lim_{x \rightarrow 0} x \int_x^1 \frac{\cos t}{t^2} dt; \quad \text{ b) } \lim_{x \rightarrow \infty} \frac{\int_0^x \sqrt{1+t^4} dt}{x^3}; \quad \text{ v) } \lim_{x \rightarrow 0} \frac{\int_0^{+\infty} t^{-1} e^{-t} dt}{\ln \frac{1}{x}}; \quad \text{ g) } \lim_{x \rightarrow 0} x^a \int_x^1 \frac{f(t)}{t^{a+1}} dt,$$

bunda $a > 0$ va $f(t) - [0, 1]$ kesmada uzluksiz funksiya.

Quyidagi integrallarning yaqinlashishini tekshiring (2358-2377):

$$2358. \int_0^{+\infty} \frac{x^2 dx}{x^4 - x^2 + 1}.$$

$$2359. \int_1^{+\infty} \frac{dx}{x^3 \sqrt{x^2 + 1}}.$$

$$2360. \int_0^2 \frac{dx}{\ln x}.$$

$$2361. \int_0^{+\infty} x^{p-1} e^{-x} dx.$$

$$2362. \int_0^1 x^p \ln^q \frac{1}{x} dx.$$

$$2363. \int_0^{+\infty} \frac{x^n}{1+x^n} dx \quad (n \geq 0).$$

$$2364. \int_0^{+\infty} \frac{\arctg ax}{x^n} dx \quad (a \neq 0).$$

$$2365. \int_0^{+\infty} \frac{\ln(1+x)}{x^n} dx.$$

$$2366. \int_0^{+\infty} \frac{x^m \arctg x}{2+x^n} dx \quad (n \geq 0).$$

$$2367. \int_0^{+\infty} \frac{\cos ax}{1+x^n} dx \quad (n \geq 0).$$

$$2368. \int_0^{+\infty} \frac{\sin^2 x}{x} dx.$$

$$2369. \int_0^{p/2} \frac{dx}{\sin^p x \cos^q x}.$$

$$2370. \int_0^1 \frac{x^n dx}{\sqrt{1-x^4}}.$$

$$2370.1. \int_0^{+\infty} \frac{dx}{\sqrt{x^3+x}}.$$

$$2371. \int_0^{+\infty} \frac{dx}{x^p + x^q}.$$

$$2372. \int_0^1 \frac{\ln x}{1-x^2} dx.$$

$$2373. \int_0^{p/2} \frac{\ln(\sin x)}{\sqrt{x}} dx.$$

$$2374. \int_1^{+\infty} \frac{dx}{x^p \ln^q x}.$$

$$2375. \int_e^{+\infty} \frac{dx}{x^p (\ln x)^q (\ln \ln x)^r}.$$

$$2376. \int_{-\infty}^{+\infty} \frac{dx}{|x-a_1|^{p_1} |x-a_2|^{p_2} \dots |x-a_n|^{p_n}} \quad (a_1 < a_2 < \dots < a_n).$$

$$2376.1. \int_0^{+\infty} x^a |x-1|^b dx.$$

$$2377. \int_0^{+\infty} \frac{P_m(x)}{P_n(x)} dx, \text{ bunda } P_m(x) \text{ va } P_n(x) - \text{ mos ravishda } m \text{ va } n - \text{ darajali o'zaro tub}$$

ko'phadlar.

Quyidagi integrallarning absolyut va shartli yaqinlashishini tekshiring (2378-2383):

$$2378. \int_0^{+\infty} \frac{\sin x}{x} dx. \quad \underline{\text{Y o' l l a n m a.}} \quad |\sin x| \geq \sin^2 x.$$

$$2379. \int_0^{+\infty} \frac{\sqrt{x} \cos x}{x+100} dx.$$

$$2380. \int_0^{+\infty} x^p \sin(x^q) dx \quad (q \neq 0).$$

$$2380.1. \int_0^{p/2} \sin(\sec x) dx.$$

$$2380.2. \int_0^{+\infty} x^2 \cos(e^x) dx.$$

$$2381. \int_0^{+\infty} \frac{x^p \sin x}{1+x^q} dx \quad (q \geq 0).$$

$$2382. \int_0^{+\infty} \frac{\sin\left(x + \frac{1}{x}\right)}{x^n} dx.$$

$$2383. \int_a^{+\infty} \frac{P_m(x)}{P_n(x)} \sin x dx, \text{ bunda } P_m(x) \text{ va } P_n(x) - \text{ mos ravishda } m \text{ va } n - \text{ darajali butun}$$

ko'phadlar va agar $x \geq a \geq 0$ bo'lsa, $P_n(x) > 0$.

$$2384. \text{ Agar } \int_a^{+\infty} f(x) dx \text{ integral yaqinlashuvchi bo'lsa, u holda, albatta, } \lim_{x \rightarrow +\infty} f(x) = 0$$

tenglik bajariladimi?

Misollar ko'ring:

$$a) \int_0^{+\infty} \sin(x^2) dx;$$

$$b) \int_0^{+\infty} (-1)^{[x^2]} dx.$$

$$2384.1. f(x) \in C^{(1)}[x_0, +\infty), x_0 \leq x < +\infty \text{ da } |f'(x)| < C \text{ va ushbu}$$

$$\int_{x_0}^{+\infty} |f(x)| dx$$

integral yaqinlashuvchi bo'lsin. U holda $x \rightarrow +\infty$ da $f(x) \rightarrow 0$ bo'lishini isbotlang.

$$\underline{\text{Y o' l l a n m a.}} \quad \int_{x_0}^{+\infty} f(x) f'(x) dx \text{ integralni ko'ring.}$$

$$2385. [a, b] \text{ kesmada aniqlangan, chegaralanmagan } f(x) \text{ funksiyaning ushbu}$$

$$\int_a^b f(x) dx$$

yaqinlashuvchi xosmas integraliga unga mos $\sum_{i=0}^{n-1} f(x_i) \Delta x_i$ integral yig'indining limiti sifatida qarash mumkinmi, bunda $x_i \leq x_{i+1}$ va $\Delta x_i = x_{i+1} - x_i$?

2386. Ushbu

$$\int_a^{+\infty} f(x) dx \quad (1)$$

integral yaqinlashuvchi va $j(x)$ funksiya chegaralangan bo'lsin. U holda

$$\int_a^{+\infty} f(x)j(x) dx \quad (2)$$

integral albatta yaqinlashuvchi bo'lishi shartmi?

Misol keltiring.

Agar (1) integral absolyut yaqinlashuvchi bo'lsa, (2) integralning yaqinlashishi haqida nima deyish mumkin?

2387. Agar $\int_a^b f(x) dx$ yaqinlashuvchi va $f(x)$ – monoton funksiya bo'lsa, u holda

$f(x) = O\left(\frac{1}{x}\right)$ tenglikni isbotlang.

2388. $f(x)$ funksiya $0 < x \leq 1$ oralig'ida monoton va $x = 0$ nuqta atrofida chegaralanmagan bo'lsin.

Agar $\int_0^1 f(x) dx$ integral mavjud bo'lsa, u holda quyidagi tenglikni isbotlang:

$$\lim_{n \rightarrow \infty} \frac{1}{n} \sum_{k=1}^n f\left(\frac{k}{n}\right) = \int_0^1 f(x) dx.$$

2389. Agar $f(x)$ funksiya $0 < x < a$ intervalda monoton va chegaralangan hamda ushbu

$$\int_0^a x^p f(x) dx$$

xosmas integral mavjud bo'lsa, u holda quyidagi tenglikni isbotlang:

$$\lim_{x \rightarrow +0} x^{p+1} f(x) = 0.$$

2390. Isbotlang:

a) v. p. $\int_{-1}^1 \frac{dx}{x} = 0$; b) v. p. $\int_0^{+\infty} \frac{dx}{1-x^2} = 0$; v) v. p. $\int_{-\infty}^{+\infty} \sin x dx = 0$.

2391. $x \geq 0$ da mavjudligini isbotlang:

$$\text{li } x = \text{v. p. } \int_0^x \frac{dx}{\ln x}.$$

Quyidagi integrallarni toping:

2392. v. p. $\int_0^{+\infty} \frac{dx}{x^2 - 3x + 2}$.

2393. v. p. $\int_{-\infty}^{+\infty} \frac{1+x}{1+x^2} dx$.

2394. v. p. $\int_{\frac{1}{2}}^2 \frac{dx}{x \ln x}$.

2395. v. p. $\int_{-\infty}^{+\infty} \text{arctg } x dx$.

5. YUzalarni hisoblash

2396. To`g`ri parabolik segmentning yuzi

$$S = \frac{2}{3}bh$$

ga teng ekanligini isbotlang, bunda b – asosi, h – segmentning balandligi.

To`g`ri burchakli koordinatalarda berilgan va quyidagi chiziqlar bilan chegaralangan figuralarning yuzini hisoblang (2397-2410):

2397. $ax = y^2, ay = x^2$.

2398. $y = x^2, x + y = 2$.

2399. $y = 2x - x^2, x + y = 0$.

2400. $y = |\lg x|, y = 0, x = 0,1, x = 10$.

2400.1. $y = 2^x, y = 2, x = 0$.

2400.2. $y = (x+1)^2, x = \sin p y, y = 0 (0 \leq y \leq 1)$.

2401. $y = x; y = x + \sin^2 x (0 \leq x \leq p)$.

2402. $y = \frac{a^3}{a^2 + x^2}, y = 0$.

2403. $\frac{x^2}{a^2} + \frac{y^2}{b^2} = 1$.

2404. $y^2 = x^2(a^2 - x^2)$.

2405. $y^2 = 2px, 27py^2 = 8(x-p)^3$.

2406. $Ax^2 + 2Bxy + Cy^2 = 1 (A > 1, AC - B^2 > 0)$.

2407. $y^2 = \frac{x^3}{2a-x}$ (tsissoida), $x = 2a$.

2408. $x = a \ln \frac{a + \sqrt{a^2 - y^2}}{y} - \sqrt{a^2 - y^2}, y = 0$ (traktrisa).

2409. $y^2 = \frac{x^n}{(1+x^{n+2})^2} (x > 0; n > -2)$.

2410. $y = e^{-x} |\sin x|, y = 0 (x \geq 0)$.

2411. $y^2 = 2x$ parabola $x^2 + y^2 = 8$ doiraning yuzini qanday nisbatda bo`ladi?

2412. $x^2 - y^2 = 1$ giperbolada yotuvchi $M(x, y)$ nuqtaning koordinatalarini $M'M$ giperbola yoyi va OM va OM' nurlar bilan chegaralangan giperbolik sektorning $S = OM'M$ yuzasining funksiyasi sifatida ifodalang, bunda $M'(x, -y) - Ox$ o`qiga nisbatan M nuqtaga simmetrik nuqtadir.

Parametrik ko`rinishda berilgan va quyidagi chiziqlar bilan chegaralangan figuralarning yuzini toping (2413-2417):

2413. $x = a(t - \sin t), y = a(1 - \cos t) (0 \leq t \leq 2p)$ (tsikloida) va $y = 0$.

2414. $x = 2t - t^2, y = 2t^2 - t^3$.

2415. $x = a(\cos t + t \sin t), y = a(\sin t - t \cos t) (0 \leq t \leq 2p)$ (doira yoyilmasi) va $x = a, y \leq 0$.

2416. $x = a(2 \cos t - \cos 2t), y = a(2 \sin t - \sin 2t)$.

2417. $x = \frac{c^2}{a} \cos^3 t, y = \frac{c^2}{b} \sin^3 t (c^2 = a^2 - b^2)$ (ellips evolyutasi).

2417.1. $x = a \cos t, y = \frac{a \sin^2 t}{2 + \sin t}$.

Qutb koordinatalarda berilgan va quyidagi chiziqlar bilan chegaralangan figuralarning yuzini toping (2418-2423):

2418. $r^2 = a^2 \cos 2j$ (lemniskata).

2419. $r = a(1 + \cos j)$ (kardioida).

2420. $r = a \sin 3j$ (uch yaproqli gul).

$$2421. r = \frac{p}{1 - \cos j} \text{ (parabola), } j = \frac{p}{4}, j = \frac{p}{2}.$$

$$2422. r = \frac{p}{1 + e \cos j} \quad (0 < e < 1) \text{ (ellips). } 2422.1. r = 3 + 2 \cos j .$$

$$2422.2. r = \frac{1}{j}, \quad r = \frac{1}{\sin j} \left(0 < j \leq \frac{p}{2} \right).$$

$$2423. r = a \cos j, \quad r = a(\cos j + \sin j) \quad \left(M\left(\frac{a}{2}, 0\right) \in S \right).$$

$$2424. j = r \operatorname{arctg} r \text{ egri chiziq va } j = 0 \text{ va } j = \frac{p}{\sqrt{3}} \text{ nurlar bilan chegaralangan sektorning}$$

yuzini toping.

$$2424.1. r^2 + j^2 = 1 \text{ egri chiziq bilan chegaralangan figuraning yuzini toping.}$$

2424.2. Quyidagi egri chiziq yaprog'i bilan chegaralangan figuraning yuzini toping:

$$j = \sin(pr) \quad (0 \leq r \leq 1).$$

2424.3. Quyidagi chiziqlar bilan chegaralangan figuraning yuzini toping:

$$j = 4r - r^3, \quad j = 0.$$

2424.4. Quyidagi chiziqlar bilan chegaralangan figuraning yuzini toping:

$$j = r - \sin r, \quad j = p.$$

2425. Quyidagi yopiq chiziq bilan chegaralangan figuraning yuzini toping:

$$r = \frac{2at}{1+t^2}, \quad j = \frac{pt}{1+t}.$$

Qutb koordinatalarga o'tib, quyidagi chiziqlar bilan chegaralangan figuralarning yuzini toping:

$$2426. x^3 + y^3 = 3axy \text{ (Dekart yaprog'i).}$$

$$2427. x^4 + y^4 = a^2(x^2 + y^2).$$

$$2428. (x^2 + y^2)^2 = 2a^2xy \text{ (lemniskata).}$$

Berilgan tenglamalarni parametrik ko'rinishgacha keltirib, quyidagi chiziqlar bilan chegaralangan figuralarning yuzini toping:

$$2429. x^{\frac{2}{3}} + y^{\frac{2}{3}} = a^{\frac{2}{3}} \text{ (astroida).}$$

$$2430. x^4 + y^4 = ax^2y.$$

Y o`l l a n m a. ($y = tx$ deb oling).

6. YOy uzunligini hisoblash

Quyidagi egri chiziqlarning yoylari uzunliklarini toping (2431-2452.3):

$$2431. y = x^{3/2} \quad (0 \leq x \leq 4).$$

$$2432. y^2 = 2px \quad (0 \leq x \leq x_0).$$

$$2433. y = a \operatorname{ch} \frac{x}{a} \text{ } A(0, a) \text{ nuqtadan } B(b, h) \text{ nuqttagacha.}$$

$$2434. y = e^x \quad (0 \leq x \leq x_0).$$

$$2435. x = \frac{1}{4}y^2 - \frac{1}{2}\ln y \quad (1 \leq y \leq e).$$

$$2436. y = a \ln \frac{a^2}{a^2 - x^2} \quad (0 \leq x \leq b < a).$$

$$2437. y = \ln \cos x \quad \left(0 \leq x \leq a < \frac{p}{2} \right).$$

$$2438. x = a \ln \frac{a + \sqrt{a^2 - y^2}}{y} - \sqrt{a^2 - y^2} \quad (0 < b \leq y \leq a).$$

$$2439. y^2 = \frac{x^3}{2a-x} \left(0 \leq x \leq \frac{5}{3}a \right). \quad 2440. x^{2/3} + y^{2/3} = a^{2/3} \text{ (astroida).}$$

$$2441. x = \frac{c^2}{a} \cos^3 t, \quad y = \frac{c^2}{b} \sin^3 t, \quad c^2 = a^2 - b^2 \text{ (ellips evolyutasi).}$$

$$2442. x = \cos^4 t, \quad y = \sin^4 t.$$

$$2443. x = a(t - \sin t), \quad y = a(1 - \cos t) \quad (0 \leq t \leq 2\pi).$$

$$2444. x = a(\cos t + t \sin t), \quad y = a(\sin t - t \cos t), \quad 0 \leq t \leq 2\pi \text{ (aylana yoyilmasi).}$$

$$2445. x = a(\operatorname{sh} t - t), \quad y = a(\operatorname{ch} t - 1) \quad (0 \leq t \leq T).$$

$$2445.1. x = \operatorname{ch}^3 t, \quad y = \operatorname{sh}^3 t \quad (0 \leq t \leq T).$$

$$2446. 0 \leq j \leq 2\pi \text{ da } r = aj \text{ (Arximed spirali).}$$

$$2447. 0 < r < a \text{ da } r = ae^{mj} \quad (m > 0).$$

$$2448. r = a(1 + \cos j).$$

$$2449. r = \frac{p}{1 + \cos j} \left(|j| \leq \frac{p}{2} \right).$$

$$2450. r = a \sin^3 \frac{j}{3}.$$

$$2451. r = a \operatorname{th} \frac{j}{2} \quad (0 \leq j \leq 2\pi).$$

$$2452. j = \frac{1}{2} \left(r + \frac{1}{r} \right) \quad (1 \leq r \leq 3).$$

$$2452.1. j = \sqrt{r} \quad (0 \leq r \leq 5).$$

$$2452.2. j = \int_0^r \frac{\operatorname{sh} r}{r} dr \quad (0 \leq r \leq R).$$

$$2452.3. r = 1 + \cos t, \quad j = t - t \operatorname{tg} \frac{t}{2} \quad (0 \leq t \leq T < \pi).$$

2453. Ushbu

$$x = a \cos t, \quad y = b \sin t$$

elips yoyining uzunligi $y = c \sin \frac{x}{b}$ sinusoidaning bitta to'liqini uzunligiga tengligini isbotlang,

bunda $c = \sqrt{a^2 - b^2}$.

2454. $4ay = x^2$ parabola Ox o'qi bo'yicha sirpanmoqda. Parabolaning fokusi zanjir chiziq hosil qilishini isbotlang.

2455. Ushbu

$$y = \pm \left(\frac{1}{3} - x \right) \sqrt{x}$$

egri chiziq xalqasi bilan chegaralangan figura yuzasining aylanasi uzunligi shu chiziq konturiga teng bo'lgan doira yuzasiga nisbatini toping.

7. Hajmlarni hisoblash

2456. Asosi tomonlari a va b bo'lgan to'g'ri to'rtburchak, yuqori qirradi c ga va balandligi h ga teng bo'lgan cherdakning hajmini toping.

2457. Parallel asoslari tomonlari A , B va a , b ga teng to'g'ri to'rtburchaklardan, balandligi esa h bo'lgan obeliskning hajmini toping (obelisk – asoslari parallel tekisliklarda yotgan bir ismli ko'pburchaklardan, yon yoqlari esa trapetsiyalardan iborat bo'lgan qavariq ko'pyoq).

2458. Asoslari yarim o'qlari A , B va a , b bo'lgan elipslardan, balandligi h ga teng bo'lgan kesik konusning hajmini toping.

2459. Asosi S ga, balandligi H ga teng bo'lgan aylanma paraboloidning hajmini toping.

2460. Jismning Ox o'qiga perpendikulyar bo'lgan ko'ndalang kesimining $S = S(x)$ yuzasi quyidagi kvadratik qonun bo'yicha o'zgarsin:

$$S(x) = Ax^2 + Bx + C \quad [a \leq x \leq b],$$

bunda A, B va S – o'zgarimas sonlar.

Bu jismning hajmi

$$V = \frac{H}{6} \left[S(a) + 4S\left(\frac{a+b}{2}\right) + S(b) \right]$$

ga tengligini isbotlang, bunda $H = b - a$ (Simpson formulasi).

2461. Jism $M(x, y, z)$ nuqtalar to'plamidan iborat, bunda $0 \leq z \leq 1$ hamda agar z ratsional bo'lsa, $0 \leq x \leq 1$, $0 \leq y \leq 1$, va agar z irratsional bo'lsa, $-1 \leq x \leq 0$, $-1 \leq y \leq 0$. Bu jismning hajmi mavjud emasligini isbotlang, vaholanki, mos integral

$$\int_0^1 S(z) dz = 1$$

ga teng.

Quyidagi sirtlar bilan chegaralangan jismlarning hajmini toping (2462-2470):

$$2462. \frac{x^2}{a^2} + \frac{y^2}{b^2} = 1, \quad z = \frac{c}{a}x, \quad z = 0.$$

$$2463. \frac{x^2}{a^2} + \frac{y^2}{b^2} + \frac{z^2}{c^2} = 1 \quad (\text{ellipsoid}).$$

$$2464. \frac{x^2}{a^2} + \frac{y^2}{b^2} - \frac{z^2}{c^2} = 1, \quad z = \pm c.$$

$$2465. x^2 + z^2 = a^2, \quad y^2 + z^2 = a^2$$

$$2466. x^2 + y^2 + z^2 = a^2, \quad x^2 + y^2 = ax.$$

$$2467. z^2 = b(a - x), \quad x^2 + y^2 = ax.$$

$$2468. \frac{x^2}{a^2} + \frac{y^2}{z^2} = 1 \quad (0 < z < a).$$

$$2469. x + y + z^2 = 1, \quad x = 0, \quad y = 0, \quad z = 0.$$

$$2470. x^2 + y^2 + z^2 + xy + yz + zx = a^2.$$

2471. Tekislikda ushbu

$$a \leq x \leq b, \quad 0 \leq y \leq y(x)$$

figuraning Oy o'qi atrofida aylanishirdan hosil bo'lgan jismning hajmi

$$V_y = 2p \int_a^b xy(x) dx$$

ga tengligini isbotlang, bunda $y(x)$ – bir qiymatli uzluksiz funksiya.

Quyidagi chiziqlarning aylanishidan hosil bo'lgan sirtlar bilan chegaralangan jismlarning hajmini toping (2472-2481):

$$2472. y = b \left(\frac{x}{a} \right)^{2/3} \quad (0 \leq x \leq a) \quad Ox \text{ o'qi atrofida (neyloid)}.$$

$$2473. y = 2x - x^2, \quad y = 0: \text{ a) } Ox \text{ o'qi atrofida; b) } Oy \text{ o'qi atrofida.}$$

$$2474. y = \sin x, \quad y = 0 \quad (0 \leq x \leq p): \text{ a) } Ox \text{ o'qi atrofida; b) } Oy \text{ o'qi atrofida.}$$

$$2475. y = b \left(\frac{x}{a} \right)^2, \quad y = b \left| \frac{x}{a} \right|: \text{ a) } Ox \text{ o'qi atrofida; b) } Oy \text{ o'qi atrofida.}$$

$$2476. y = e^{-x}, \quad y = 0 \quad (0 \leq x < +\infty): \text{ a) } Ox \text{ o'qi atrofida; b) } Oy \text{ o'qi atrofida.}$$

$$2477. x^2 + (y - b)^2 = a^2 \quad (0 < a \leq b) \quad Ox \text{ o'qi atrofida.}$$

$$2478. x^2 - xy + y^2 = a^2 \quad Ox \text{ o'qi atrofida.}$$

$$2479. y = e^{-x} \sqrt{\sin x} \quad (0 \leq x < +\infty) \quad Ox \text{ o'qi atrofida.}$$

2480. $x = a(t - \sin t)$, $y = a(1 - \cos t)$ ($0 \leq t \leq 2p$), $y = 0$: a) Ox o'qi atrofida; b) Oy o'qi atrofida; v) $y = 2a$ to'g'ri chiziq atrofida.

2481. $x = a \sin^3 t$, $y = b \cos^3 t$ ($0 \leq t \leq 2p$) a) Ox o`qi atrofida; b) Oy o`qi atrofida.

2481.1. $x = 2t - t^2$, $y = 4t - t^3$ egri chiziq xalqasi yuzasining a) Ox o`qi atrofida; b) Oy o`qi atrofida aylanishidan hosil bo`lgan jismning hajmini toping.

2482. Tekislikda ushbu

$$0 \leq a \leq j \leq b \leq p, \quad 0 \leq r \leq r(j)$$

figuraning qutb o`qi atrofida aylanishidan hosil bo`lgan jismning hajmi

$$V = \frac{2p}{3} \int_a^b r^3(j) \sin j \, dj$$

ga tengligini isbotlang (j va r – qutb koordinatalar).

Qutb koordinatalarda berilgan tekislikdagi figuralarning aylanishidan hosil bo`lgan jismlarning hajmlarini toping:

2483. $r = a(1 + \cos j)$ ($0 \leq j \leq 2p$): a) qutb o`qi atrofida; b) $r \cos j = -\frac{a}{4}$ to`g`ri chiziq atrofida.

2484. $(x^2 + y^2)^2 = a^2(x^2 - y^2)$: a) Ox o`qi atrofida; b) Oy o`qi atrofida; v) $y = x$ to`g`ri chiziq atrofida.

Y o`l l a n m a. Qutb koordinatalarga o`ting.

2484.1. Ushbu

$$r = aj \quad (a > 0, 0 \leq j \leq p)$$

Arximed spirali yarimo`rami bilan chegaralangan figuraning qutb o`qi atrofida aylanishidan hosil bo`lgan jismning hajmini toping.

2484.2. Ushbu

$$j = pr^3, \quad j = p$$

chiziqlar bilan chegaralangan figuraning qutb o`qi atrofida aylanishidan hosil bo`lgan jismning hajmini toping.

2485. Ushbu

$$a \leq r \leq a\sqrt{2 \sin 2j}$$

figuraning qutb o`qi atrofida aylanishidan hosil bo`lgan jismning hajmini toping.

8. Aylanma sirt yuzalarini hisoblash

Quyidagi chiziqlarning aylanishidan hosil bo`lgan sirt yuzalarini toping (2486-2498):

2486. $y = x\sqrt{\frac{x}{a}}$ ($0 \leq x \leq a$) Ox o`qi atrofida.

2487. $y = a \cos \frac{px}{2b}$ ($|x| \leq b$) Ox o`qi atrofida.

2488. $y = tg x \left(0 \leq x \leq \frac{p}{4} \right)$ Ox o`qi atrofida.

2489. $y^2 = 2px$ ($0 \leq x \leq x_0$): a) Ox o`qi atrofida; b) Oy o`qi atrofida.

2490. $\frac{x^2}{a^2} + \frac{y^2}{b^2} = 1$ ($0 < b \leq a$): a) Ox o`qi atrofida; b) Oy o`qi atrofida.

2491. $x^2 + (y - b)^2 = a^2$ ($b \geq a$) Ox o`qi atrofida.

2492. $x^{2/3} + y^{2/3} = a^{2/3}$ Ox o`qi atrofida.

2493. $y = a \operatorname{ch} \frac{x}{a}$ ($|x| \leq b$): a) Ox o`qi atrofida; b) Oy o`qi atrofida.

2494. $\pm x = a \ln \frac{a + \sqrt{a^2 - y^2}}{y} - \sqrt{a^2 - y^2}$ Ox o`qi atrofida.

2495. $x = a(t - \sin t)$, $y = a(1 - \cos t)$ ($0 \leq t \leq 2\pi$): a) Ox o`qi atrofida; b) Oy o`qi atrofida; v) $y = 2a$ to`g`ri chiziq atrofida.

2496. $x = a \cos^3 t$, $y = a \sin^3 t$: $y = x$ to`g`ri chiziq atrofida.

2497. $r = a(1 + \cos j)$ qutb o`qi atrofida.

2498. $r^2 = a^2 \cos 2j$: a) qutb o`qi atrofida; b) $j = \frac{p}{2}$ o`q atrofida; v) $j = \frac{p}{4}$ o`q atrofida.

2499. $ay = a^2 - x^2$ parabola va Ox o`qi bilan chegaralangan figuraning Ox o`qi atrofida aylanishidan hosil bo`lgan jism sirti yuzasining unga tengdosh shar sirti yuzasiga nisbatini toping.

2500. $y^2 = 2px$ parabola va $x = p/2$ to`g`ri chiq bilan chegaralangan figuraning $y = p$ to`g`ri chiziq atrofida aylanishidan hosil bo`lgan jismning hajmini va sirti yuzasini toping.

JAVOBLAR

I-BO`LIM

16. 0; 1. 17. $-\sqrt{2}$; $\sqrt{2}$. 22. $-1,01 < x < -0,99$. 23. $x \leq -8$; $x \geq 12$. 24. $x < -\frac{1}{2}$. 25. $0 < x < \frac{2}{3}$. 26. $|x| \leq 6$. 27. $x > -\frac{1}{2}$. 28. $-\frac{1}{2} < x < \frac{1}{2}$. 29. $\frac{5-\sqrt{30}}{10} < x < \frac{5-\sqrt{20}}{10}$; $\frac{5+\sqrt{20}}{10} < x < \frac{5+\sqrt{30}}{10}$. 31. Ikkinchisi. 32. Ikkita ishora. 33. 0,41 % dan ortiq emas. 34. $9,9102 \text{ sm}^2 \leq S \leq 10,0902 \text{ sm}^2$; $\Delta \leq 0,0902 \text{ sm}^2$; $d \leq 0,91\%$. 35. $3,93 \text{ gs/sm}^3 \pm 0,27 \text{ gs/sm}^3$; $d \leq 7,3\%$. 36. $d \leq 3,05\%$. 37. $172,480 \text{ m}^3 \leq v \leq 213,642 \text{ m}^3$; $v = 192,660 \text{ m}^3 \pm 20,982 \text{ m}^3$; $d \approx 12\%$. 38. $\Delta \leq 0,17 \text{ mm}$. 39. $\Delta < 0,0005 \text{ m}$. 42. a) $N \geq \frac{1}{e}$; b) $N \geq \sqrt{\frac{2}{e}}$; v) $N \geq 1 + \frac{\lg \frac{1}{e}}{\lg 2}$; g) $N \geq \frac{\lg e}{\lg 0,999} \approx 2330 \lg \frac{1}{e}$. 43. a) $N \geq E$; b) $N \geq \left(\frac{\lg E}{\lg 2}\right)^2$; v) $N \geq 10^{10}$. 46. 0. 47. 0. 48. 0. 49. $\frac{1}{3}$. 50. $\frac{1-b}{1-a}$. 51. $\frac{1}{2}$. 52. $\frac{1}{2}$. 53. $\frac{1}{3}$. 54. $\frac{4}{3}$. 55. 3. 56. 1. 57. 2. 67. a) ikkinchisi; b) birinchisi; v) ikkinchisi. 72. $e = 2,71828 \dots$. 92. Agar $a \neq 0$ bo`lsa, 1 ga teng va $a = 0$ bo`lsa, $[-1, 1]$ kesmaga tegishli yoki mavjud emas. 96. $x_3 = 1\frac{1}{8}$. 97. $x_{100} = \frac{1}{20}$. 98. $x_{1000} = \frac{1000^{1000}}{1000!} \approx 2,49 \cdot 10^{452}$. 99. $x_4 = x_5 = -120$. 100. $x_{10} = 20$. 101. 0; 1; 1; 1. 101.1. $-3\frac{1}{2}$; 5; -2; 2. 102. -1; $1\frac{1}{2}$; 0; 1. 103. 0; 2; 0; 2. 104. -4; 6; -4; 6. 105. $-\frac{1}{2}$; 1; $-\frac{1}{2}$; 1. 106. $-\infty$; $+\infty$; $-\infty$; $+\infty$. 107. $-\infty$; -1; $-\infty$; $-\infty$. 108. 0; $+\infty$; 0; $+\infty$. 109. $-\infty$; $+\infty$; $-\infty$; $+\infty$. 110. -5; 1,25; 0; 0. 111. $-\frac{1}{2}$; 1. 112. $-\left(e + \frac{1}{\sqrt{2}}\right)$; $e + 1$. 113. 0; 1. 114. 1; 2. 115. 0; 1. 116. 0; 1. 117. 1; $\frac{1}{2}$; $\frac{1}{3}$; 0. 118. $[0, 1]$ kesmadagi barcha haqiqiy sonlar. 119. 1, 5. 120. a; b. 127. a) uzoqlashuvchi, b) yaqinlashuvchi ham, uzoqlashuvchi ham bo`lishi mumkin. 128. a) yo`q; b) yo`q. 129. yo`q. 130. yo`q. 144. a) 0; b) 0. 147. $\ln 2$. 148. $\frac{1}{3}(a + 2b)$. 151. $-\infty < x < +\infty$; $x \neq -1$. 152. $-\infty < x \leq -\sqrt{3}$ va $0 \leq x \leq \sqrt{3}$. 153. $-1 \leq x < 1$. 154. a) $|x| > 2$; b) $x > 2$. 155. $4k^2 p^2 \leq x \leq (2k+1)^2 p^2$ ($k = 0, 1, 2, \dots$). 156. $|x| \leq \sqrt{\frac{p}{2}}$ va $\sqrt{\frac{p}{2}}(4k-1) \leq \dots \leq |x| \leq \sqrt{\frac{p}{2}}(4k+1)$ ($k = 1, 2, \dots$). 157. $\frac{1}{2k+1} < x < \frac{1}{2k}$ va $-\frac{1}{2k+1} < x < -\frac{1}{2k+2}$ ($k = 0, 1, 2, \dots$). 158. $x > 0$, $x \neq n$ ($n = 1, 2, \dots$). 159. $-\frac{1}{3} \leq x \leq 1$. 160. $|x - kp| \leq \frac{p}{6}$ ($k = 0, +1, \pm 2, \dots$). 161. $10^{\left(2k-\frac{1}{2}\right)p} < x < 10^{\left(2k+\frac{1}{2}\right)p}$ ($k = 0, +1, \pm 2, \dots$). 162. $x = -1, -2, -3, \dots$ va $x \geq 0$. 163. $x < 0$, $x \neq -n$ ($n = 1, 2, \dots$). 164. $1 < x \leq 2$. 165. $x = \frac{1}{2}, 1, \frac{3}{2}, 2, \dots$. 165.1. $x > 4$. 165.2.

$kp + \frac{p}{4} \leq x < kp + \frac{p}{2}$ ($k = 0, \pm 1, \dots$) **165.3.** $0 \leq x \leq \frac{p}{3}$ va $\frac{4p}{3} \leq x \leq \frac{3p}{2}$. **166.** $-1 \leq x \leq 2$;
 $0 \leq y \leq 1$. **167.** $2kp + \frac{p}{3} < x < 2kp + \frac{5p}{3}$ ($k = 0, \pm 1, \pm 2, \dots$); $-\infty < y \leq \lg 3$. **168.** $-\infty < x < +\infty$;
 $0 \leq y \leq p$. **169.** $1 \leq x \leq 100$; $-\frac{p}{2} \leq y \leq \frac{p}{2}$. **170.** $x = \frac{p}{2q+1}$, bunda p va q – butun sonlar; $y = \pm 1$.
171. $P = 2b + 2\left(1 - \frac{b}{h}\right)x$ ($0 < x < h$) $S = bx\left(1 - \frac{x}{h}\right)$ ($0 < x < h$). **172.** $a = \sqrt{100 - 96 \cos x}$
($0 < x < p$), $S = 24 \sin x$ ($0 < x < p$). **173.** Agar $0 \leq x \leq \frac{a-b}{2}$ bo`lsa, $S = \frac{h}{a-b}x^2$; agar
 $\frac{a-b}{2} < x < \frac{a+b}{2}$ bo`lsa, $S = h\left(x - \frac{a-b}{4}\right)$; agar $\frac{a+b}{2} \leq x \leq a$ bo`lsa, $S = h\left[\frac{a+b}{2} - \frac{(a-x)^2}{a-b}\right]$.
174. Agar $-\infty < x \leq 0$ bo`lsa, $m(x) = 0$; agar $0 < x \leq 1$ bo`lsa, $m(x) = 2x$; agar $1 < x \leq 2$ bo`lsa,
 $m(x) = 2$; agar $2 < x \leq 3$ bo`lsa, $m(x) = 3$; agar $3 < x < +\infty$ bo`lsa, $m(x) = 4$. **178.**
 $E_y = \{0 \leq y \leq 4\}$. **179.** $E_y = \{1 < y < 3\}$. **180.** $E_y = \{0 < y < 1\}$. **181.** $E_y = \{1 \leq |y| < +\infty\}$. **182.**
 $E_y = \{1 \leq y \leq 2\}$. **183.** $a < b$ bo`lganda $a < y < b$ va $a > b$ bo`lganda $b < y < a$. **184.** $1 < y < +\infty$.
185. $0 > y > -\infty$ va $+\infty > y > 1$. **186.** $0 < y \leq \frac{1}{2}$. **187.** $+\infty > y > -\infty$. **188.** $0 < y < \frac{1}{2}$ va $\frac{3}{2} \leq y < 2$.
189. 0; 0; 0; 0; 24. **190.** 0; -6; 4. **191.** 1; 1; 1; 2. **192.** -1; 0; 1; 2; 4. **193.** 1, $\frac{1+x}{1-x}$, $\frac{-x}{2+x}$, $\frac{2}{1+x}$,
 $\frac{x-1}{x+1}$, $\frac{1+x}{1-x}$. **194.** a) agar $x = -1$, $x = 0$ va $x = 1$ bo`lsa, $f(x) = 0$; agar $-\infty < x < -1$ va $0 < x < 1$
bo`lsa, $f(x) > 0$; agar $-1 < x < 0$ va $1 < x < +\infty$ bo`lsa, $f(x) < 0$; b) agar $x = \pm \frac{1}{k}$ bo`lsa,
 $f(x) = 0$; agar $\frac{1}{2k+1} < x < \frac{1}{2k}$ va $-\frac{1}{2k+1} < x < -\frac{1}{2k+2}$ ($k = 0, 1, 2, \dots$) bo`lsa, $f(x) > 0$; agar
 $\frac{1}{2k+2} < x < \frac{1}{2k+1}$ va $-\frac{1}{2k} < x < -\frac{1}{2k+1}$ ($k = 0, 1, 2, \dots$) bo`lsa, $f(x) < 0$; v) agar $x \leq 0$ va
 $x = 1$ bo`lsa, $f(x) = 0$; agar $0 < x < 1$ bo`lsa, $f(x) > 0$; agar $1 < x < +\infty$ bo`lsa, $f(x) < 0$. **195.**
a) a ; b) $2x + h$; v) $a^x \cdot \frac{a^h - 1}{h}$. **197.** $f(x) = \frac{7}{3}x - 2$; $f(1) = \frac{1}{3}$; $f(2) = 2\frac{2}{3}$. **198.**
 $f(x) = \frac{7}{6}x^2 + \frac{17}{6}x + 1$; $f(-1) = -\frac{2}{3}$; $f(0,5) = 2\frac{17}{24}$. **199.** $f(x) = \frac{10}{3}x^3 - \frac{7}{2}x^2 - \frac{29}{6}x + 2$. **200.**
 $f(x) = 10 + 5 \cdot 2^x$. **203.** a) $2kp < x < p + 2kp$ ($k = 0, \pm 1, \pm 2, \dots$); b) $1 < x < e$; v) $x > 0$,
 $x \neq k$ ($k = 0, 1, 2, \dots$). **205.** a) $z = x + y$; b) $z = \frac{xy}{x+y}$; v) $z = \frac{x+y}{1-xy}$; g) $z = \frac{x+y}{1+xy}$. **206.**
 $j(j(x)) = x^4$; $y(y(x)) = 2^{2x}$; $j(y(x)) = 2^{2x}$; $y(j(x)) = 2^{x^2}$. **207.** $j(j(x)) = \operatorname{sgn} x$;
 $y(y(x)) = x$ ($x \neq 0$); $j(y(x)) = y(j(x)) = \operatorname{sgn} x$ ($x \neq 0$). **208.** $j(j(x)) = j(x)$;
 $y(j(x)) = y(x)$; $y(y(x)) = j(y(x)) = 0$. **209.** $-\frac{1-x}{x}$; x ($x \neq 0, x \neq 1$). **210.**
 $f_n(x) = \frac{x}{\sqrt{1+nx^2}}$. **211.** $x^2 - 5x + 6$. **212.** $x^2 - 2$ ($|x| \geq 2\frac{1}{2}$). **213.** $\frac{1 + \sqrt{1+x^2}}{x}$. **213.1.**

$f(x) = \left(\frac{x}{1-x}\right)^2$. **221.** a) $a > 0$ da o'suvchi va $a < 0$ da kamayuvchi; b) $a > 0$ bo'lganda $\left(-\infty, -\frac{b}{2a}\right)$ orliqda kamayuvchi va $\left(-\frac{b}{2a}, +\infty\right)$ oraliqda o'suvchi; v) o'suvchi; g) $ad - bc > 0$ bo'lganda $\left(-\infty, -\frac{d}{c}\right)$ va $\left(-\frac{d}{c}, +\infty\right)$ orliqlarda o'suvchi; d) $a > 1$ da o'suvchi va $0 < a < 1$ da kamayuvchi. **222.** Agar logarifmning asosi 1 dan katta bo'lsa mumkin. **224.** $\frac{y-3}{2} (-\infty < y < +\infty)$. **225.** a) $-\sqrt{y} (0 \leq y < +\infty)$; b) $\sqrt{y} (0 \leq y < +\infty)$. **226.** $\frac{1-y}{1+y} (y \neq -1)$. **227.** a) $-\sqrt{1-y^2} (0 \leq y \leq 1)$; b) $\sqrt{1-y^2} (0 \leq y \leq 1)$. **228.** $Arsh y = \ln(y + \sqrt{1+y^2}) (-\infty < y < +\infty)$. **229.** $Arthy = \frac{1}{2} \ln \frac{1+y}{1-y} (-1 < y < 1)$. **230.** Agar $-\infty < y < 1$ bo'lsa, $x = y$; agar $1 \leq y \leq 16$ bo'lsa, $x = \sqrt{y}$; agar $16 < y < +\infty$ bo'lsa, $x = \log_2 y$. **231.** a) Toq; b) juft; v) juft; g) toq; d) toq. **233.** a) Davriy, $T = 2p/l$; b) davriy, $T = 2p$; v) davriy, $T = 6p$; g) davriy, $T = p$; d) davriy emas; e) davriy $T = p$; j) davriy emas; z) davriy emas. **241.** $t = 1\frac{2}{3}$ s, $x = -3\frac{1}{3}$ m. **243.** $x_0 = -\frac{b}{2a}$, $y_0 = \frac{4ac - b^2}{4a}$. **244.** $y = x - \frac{x^2}{36000}$; 9 km; 36 km. **251.** $x_0 = -\frac{d}{c}$; $y_0 = \frac{a}{c}$. **252.** $p = \frac{12}{v} (v > 0)$. **263.** $k = \frac{a}{a_1}$, $m = \frac{a_1 b - ab_1}{a_1^2}$, $n = \frac{c}{a_1} - \frac{b_1}{a_1^3} (a_1 b - ab_1)$, $x_0 = -\frac{b_1}{a_1}$. **264.** $y = \frac{10}{x^2}$. **287.** $A = \sqrt{a^2 + b^2}$; $\sin x_0 = -\frac{a}{A}$, $\cos x_0 = \frac{b}{A}$. **356.** Agar $|x - pk| \leq \frac{p}{6}$ bo'lsa, $y = 2 \sin x$ va agar $\frac{p}{6} < |x - pk| < \frac{5p}{6}$ ($k = 0, \pm 1, \pm 2, \dots$) bo'lsa, $y = (-1)^k$. **357.** a) $y = \frac{1}{2}(x + |x|)$; b) va v) agar $x \geq 0$ bo'lsa, $y = x^2$; agar $x < 0$ bo'lsa, $y = 0$; g) agar $x < 0$ bo'lsa, $y = x$; agar $x \geq 0$ bo'lsa, $y = x^4$. **358.** a) $y = 1$; b) agar $1 \leq |x| \leq \sqrt{3}$ bo'lsa, $y = 1$; agar $|x| < 1$ yoki $|x| > \sqrt{3}$ bo'lsa, $y = 0$; v) agar $|x| \leq 1$ bo'lsa, $y = 1$; agar $|x| > 1$ bo'lsa, $y = 2$; g) agar $|x| > 2$ bo'lsa, $y = -2$; agar $|x| \leq 2$ bo'lsa, $y = 2 - (2 - x^2)^2$. **359.** $x < 0$ da egamiz: a) 1) $f(x) = 1 + x$, 2) $f(x) = -(1 + x)$; b) 1) $f(x) = -2x - x^2$, 2) $f(x) = 2x + x^2$; v) 1) $f(x) = \sqrt{-x}$, 2) $f(x) = -\sqrt{-x}$; g) 1) $f(x) = -\sin x$, 2) $f(x) = \sin x$; d) 1) $f(x) = e^{-x}$, 2) $f(x) = -e^{-x}$; e) 1) $f(x) = \ln(-x)$, 2) $f(x) = -\ln(-x)$. **360.** a) $x = -\frac{b}{2a}$; b) $x = \frac{1}{2}$; v) $x = \frac{b-a}{2}$; g) $x = kp$ ($k = 0, \pm 1, \pm 2, \dots$). **361.** a) $(x_0, ax_0 + b)$, bunda x_0 - ixtiyoriy; b) $\left(-\frac{d}{c}, \frac{a}{c}\right)$; v) (x_0, y_0) , bunda $x_0 = -\frac{b}{3a}$ va $y_0 = ax_0^3 + bx_0^2 + cx_0 + d$; g) $(2, 0)$; d) $(2, 1)$. **372.** Ildizlari: -1,88; 0,35; 1,53. **373.** 2,11; -0,25; -1,86. **374.** 0,25; 1,49. **375.** 0,64. **376.** 1,37; 10. **377.** -0,54. **378.** 0; 4,49. **379.** $x_1 = -0,57$, $y_1 = -1,26$; $x_2 = -0,42$, $y_2 = 1,19$; $x_3 = 0,45$, $y_3 = 0,74$; $x_4 = 0,54$, $y_4 = -0,68$. **380.** $x_1 = -1,30$, $y_1 = 9,91$; $x_2 = 2,30$, $y_2 = 9,73$; $x_3 = -0,62$, $y_3 = -9,98$; $x_4 = 1,62$, $y_4 = -9,87$. **382.** a) Umuman olganda yo'q; b) ha. **385.** YUqoridan chegaralangan va quyidan chegaralanmagan. **387.** $f(a)$ va $f(b)$. **388.** 0; 25. **389.** 0; 1.

390. 0; 1. **391.** 2; $+\infty$. **392.** -1; 1. **393.** $-\sqrt{2}$; $\sqrt{2}$. **394.** $\frac{1}{2}$; 4. **395.** a) 0, 1; b) 0; 2. **396.** 0; 1. **397.** a) 8; v) 0,8; g) 0,008. **398.** a) p ; b) \bar{p} ; v) p ; g) p . **411.** a) 1; b) $\frac{2}{3}$; v) $\frac{1}{2}$. **412.** 6. **413.** 10. **414.** $\frac{1}{2}nm(n-m)$. **415.** 5^{-5} . **416.** $\left(\frac{3}{2}\right)^{30}$. **417.** $n^{\frac{n(n+1)}{2}}$. **418.** $-\frac{1}{2}$. **419.** $\frac{1}{2}$. **420.** 1. **421.** $\frac{1}{4}$. **422.** $\frac{1}{3}$. **423.** $\left(\frac{3}{2}\right)^{10}$. **424.** $\frac{n(n+1)}{2}$. **424.1.** $2\frac{1}{24}$. **425.** $\frac{m}{n}$. **426.** $\frac{n(n-1)}{2}a^{n-2}$. **427.** $\frac{n(n+1)}{2}$. **428.** $\frac{m-n}{2}$. **429.** $x + \frac{a}{2}$. **430.** $x^2 + ax + \frac{a^2}{3}$. **431.** 1. **432.** $\frac{1}{2}$. **433.** 3. **434.** $\frac{ab}{3}$. **435.** 1. **436.** $\frac{1}{\sqrt{2}}$. **437.** $\frac{4}{3}$. **438.** -2. **439.** $\frac{1}{\sqrt{2a}}$. **440.** $-\frac{1}{16}$. **441.** $\frac{1}{144}$. **442.** $\frac{1}{4}$. **443.** $\frac{12}{5}$. **444.** $\frac{1}{n}$. **445.** -2. **446.** $\frac{1}{4}$. **447.** $\frac{2}{27}$. **448.** $\frac{3}{2}$. **449.** $4\frac{4}{27}$. **450.** $\frac{7}{36}$. **451.** $-\frac{1}{2}$. **452.** $\frac{a}{m} - \frac{b}{n}$. **453.** $\frac{a}{m} + \frac{b}{n}$. **455.** $\frac{n}{m}$. **455.1.** $\frac{1}{2}$. **456.** $\frac{1}{n!}$. **457.** $\frac{1}{2}(a+b)$. **458.** $\frac{1}{2}$. **459.** $-\frac{1}{4}$. **460.** 1. **461.** $\frac{2}{3}$. **462.** 2. **463.** $\frac{4}{3}$. **464.** $-\frac{1}{4}$. **465.** $\frac{1}{n}(a_1 + a_2 + \dots + a_n)$. **466.** 2^n . **467.** $2n$. **468.** $\lim_{a \rightarrow 0} x_1 = \infty$, $\lim_{a \rightarrow 0} x_2 = -\frac{c}{b}$. **469.** $a = 1$, $b = -1$. **470.** $a_i = \pm 1$; $b_i = m\frac{1}{2}$ ($i = 1, 2$). **471.** 5. **472.** 0. **473.** $(-1)^{m-n}\frac{m}{n}$. **474.** $\frac{1}{2}$. **474.1.** 1. **474.2.** $\frac{1}{3}$. **475.** $\frac{1}{2}$. **476.** 2. **477.** 4. **478.** $\frac{1}{p}$. **479.** $\frac{1}{2}$. **480.** $\frac{2}{p}$. **482.** $\cos a$. **483.** $-\sin a$. **484.** $\sec^2 a$ $\left(a \neq (2k+1)\frac{p}{2}, k = 0, \pm 1, \dots\right)$. **485.** $-\frac{1}{\sin^2 a}$ ($a \neq kp, k \in Z$). **486.** $\frac{\sin a}{\cos^2 a}$ ($a \neq (2k+1)\frac{p}{2}, k \in Z$). **487.** $-\frac{\cos a}{\sin^2 a}$ ($a \neq kp, k \in Z$). **488.** $-\sin a$. **489.** $-\cos a$. **490.** $\frac{2\sin a}{\cos^3 a}$ ($a \neq (2k+1)\frac{p}{2}, k \in Z$). **491.** $\frac{2\cos a}{\sin^3 a}$ ($a \neq kp, k \in Z$). **492.** $\frac{3}{2}\sin 2a$. **493.** -3. **494.** 14. **495.** $\frac{1}{\sqrt{3}}$. **496.** -24. **497.** $-\frac{\cos 2a}{\cos^4 a}$ $\left(a \neq (2k+1)\frac{p}{2}, k \in Z\right)$. **498.** $\frac{3}{4}$. **499.** $\frac{1}{4}$. **500.** $\frac{4}{3}$. **501.** $-\frac{1}{12}$. **502.** $\sqrt{2}$. **503.** 0. **504.** 3. **505.** 0. **506.** a) $\frac{1}{2}$; b) $\sqrt{\frac{2}{3}}$; v) 1. **507.** 0. **508.** 0. **509.** 0. **510.** 0. **511.** 1. **512.** e^3 . **513.** 1. **514.** e^{-2} . **515.** e^{2a} . **516.** Agar $a_1 < a_2$ bo`lsa, 0; agar $a_1 > a_2$ bo`lsa, $+\infty$; agar $a_1 = a_2$ bo`lsa, $e^{b_1 - b_2/a_1}$. **517.** e . **518.** e^{-1} . **519.** 1. **519.1.** \sqrt{e} . **520.** e^{ciga} ($a \neq kp, k \in Z$). **521.** $e^{3/2}$. **522.** e^{-1} . **523.** 1. **524.** e^{-2} . **525.** e . **526.** $\frac{1}{\sqrt{e}}$. **527.** e^{x+1} . **528.** $e^{-x^2/2}$. **529.** 1. **530.** 1. **531.** $\frac{1}{a}$. **532.** 0. **533.** $\frac{1}{5}$. **534.** -2. **535.** $\frac{3}{2}$. **536.** $\frac{3}{2}$. **537.** $-\frac{\log e}{x^2}$. **538.** $\frac{2a}{b}$. **539.** $\left(\frac{a}{b}\right)^2$. **540.** 0. **540.1.** n . **541.** $\ln a$. **542.** $a^a \ln \frac{a}{e}$. **543.** $a^a \ln(ea)$. **544.** e^2 . **545.** $\frac{2}{3}$. **545.1.** $e^{b^2 - a^2}$. **545.2.** $\frac{a}{b}$. **545.3.** -2. **546.** e^2 . **547.** 1. **548.** $\frac{a}{b}a^{a-b}$. **549.** $a^b \ln a$. **550.** $a^x \ln^2 a$. **551.** $e^{-(a+b)}$. **552.** $\ln x$. **553.** $\ln x$. **554.** $\sqrt[3]{b}$. **555.** \sqrt{ab} . **556.** $\sqrt[3]{abc}$. **557.** $(a^a b^b c^c)^{1/(a+b+c)}$. **558.** $\frac{1}{\sqrt{ab}}$. **559.** $\left(\ln \frac{a}{b}\right)^{-1}$. **560.** $a^a \ln a$. **561.** a) 0; b) $\frac{\ln 3}{\ln 2}$. **562.** $\ln 8$. **563.** $-\ln 2$.

566. a) $\frac{1}{2}$; b) $\frac{1}{2}$. **567.** 1. **568.** 0. **569.** $\ln a^2$. **570.** $\frac{1}{8}$. **571.** $\frac{1}{2}$. **572.** -2. **573.** e^2 . **574.** $e^{2/p}$. **575.** $\frac{a+b}{\sqrt{ab}}$. **576.** a) 1; b) $\frac{1}{2}$; v) 1. **576.1.** $\frac{2}{9}$. **577.** $2sh\frac{1}{2}$. **577.1.** a) cha ; b) sha . **577.2.** -1. **578.** $\ln 2$.

579. 1. **580.** e^{p^2} . **581.** $-\frac{p}{2}$. **582.** $\frac{p}{3}$. **583.** $-\frac{p}{2}$. **584.** $\frac{3p}{4}$. **585.** $\frac{1}{1+x^2}$. **586.** 2. **587.** $\frac{e^x}{x^2+1}$. **588.** $\frac{1}{2}$.

589. 1. **590.** $e^{2/p}$. **591.** 0. **592.** 0. **593.** a) $+\infty$; b) $\frac{1}{2}$. **594.** a) -1; b) 1. **594.1.** $\ln \frac{b^2}{a^2}$. **595.** a) $\frac{p}{2}$; b) $-\frac{p}{2}$. **596.** a) 1; b) 0. **597.** a) 0; b) 1. **600.** 2; 1; 2. **601.** 0; $(-1)^{n-1}$; $(-1)^n$. **602.** 0. **603.** 1. **604.** 0. **605.** 1. **606.** 0. **613.** b) Agar $|x| < 1$ bo`lsa, $y = 1$; agar $|x| = 1$ bo`lsa, $y = 0$. **614.** b) Agar $0 \leq x < 1$ bo`lsa, $y = 0$; agar $x = 1$ bo`lsa, $y = \frac{1}{2}$; agar $1 < x < +\infty$ bo`lsa, $y = 1$. **615.** Agar $0 < |x| < 1$ bo`lsa, $y = -1$; agar $|x| = 1$ bo`lsa, $y = 0$; agar $|x| > 1$ bo`lsa, $y = 1$. **616.** $y = |x|$. **617.** Agar $0 \leq x \leq 1$ bo`lsa, $y = 1$; agar $x > 1$ bo`lsa, $y = x$. **618.** Agar $0 \leq x \leq 1$ bo`lsa, $y = 1$; agar $1 < x < 2$ bo`lsa, $y = x$; agar $x \geq 2$ bo`lsa, $y = \frac{x^2}{2}$. **619.** Agar $0 \leq x < 2$ bo`lsa, $y = 0$; agar $x = 2$ bo`lsa, $y = 2\sqrt{2}$; agar $x > 2$ bo`lsa, $y = x^2$. **620.** b) Agar $x \neq (2k+1)\frac{p}{2}$ bo`lsa, $y = 0$; agar $x = (2k+1)\frac{p}{2}$ bo`lsa, $y = 1$, ($k = 0, \pm 1, \pm 2, \dots$). **621.** Agar $0 \leq x \leq 2$ bo`lsa, $y = \ln 2$; agar $x > 2$ bo`lsa, $y = \ln x$. **622.** Agar $-1 < x \leq 1$ bo`lsa, $y = 0$; agar $x > 1$ bo`lsa, $y = \frac{p}{2}(x-1)$. **623.** Agar $x \leq -1$ bo`lsa, $y = 1$; agar $x > -1$ bo`lsa, $y = e^{x+1}$. **624.** Agar $x < 0$ bo`lsa, $y = x$; agar $x = 0$ bo`lsa, $y = \frac{1}{2}$; agar $x > 0$ bo`lsa, $y = 1$. **625.** $\frac{1}{x}$. **625.1.** $0 \leq x < 1$ va $4k-1 < x < 4k+1$ larda $y = \sqrt{x}$; $4k-3 < x < 4k-2$ va $4k-2 < x < 4k-1$ larda $y = x$; $x = 2k-1$ larda $y = \frac{1}{2}(\sqrt{x} + x)$ ($k = 1, 2, 3, \dots$). **625.2.** Agar x -ratsional bo`lsa, $y = 0$; agar x -irratsional bo`lsa, $y = x$. **625.3.** $\max\{|x|, |y|\} = 1$ - kvadrat konturi. **627** a) $x = 1$; $x = -2$; $y = x - 1$; b) $x \rightarrow +\infty$ da $y = x + \frac{1}{2}$, $x \rightarrow -\infty$ da $y = -x - \frac{1}{2}$; v) $y = \frac{1}{3} - x$; g) $x \rightarrow +\infty$ da $y = x$, $x \rightarrow -\infty$ da $y = 0$; d) $x \rightarrow -\infty$ da $y = 0$, $x \rightarrow +\infty$ da $y = x$; e) $y = x + \frac{p}{2}$. **628.** 0. **629.** $\frac{1}{1-x}$. **630.** $\frac{\sin x}{x}$. **632.** $\frac{1}{6}$. **633.** $\frac{a}{2}$. **634.** $\frac{1}{2} \ln a$. **635.** \sqrt{e} . **636.** $e^{-a^2/6}$. **637.** $\frac{1}{2}(1 + \sqrt{1+4a})$. **637.1.** $\frac{2}{3}$. **637.2.** $\frac{b}{1-a}$. **637.3.** $\frac{\sqrt{5}-1}{2}$. **638.** $\sqrt{1+x} - 1$. **639.** $1 - \sqrt{1-x}$. **641.** a) 2; b) $+\infty$; v) 0; g) 1; d) 2; e) 1; j) $2sh1$. **643.** a) $l = -1$, $L = 2$; b) $l = -2$, $L = 2$; v) $l = 2$, $L = e$. **644.** a) $l = -1$, $L = 1$; b) $l = 0$, $L = +\infty$; v) $l = \frac{1}{2}$, $L = 2$; g) $l = 0$, $L = +\infty$. **645.** a) Birinchi tartibli; b) ikkinchi; v) birinchi; g) uchinchi; d) uchinchi; e) uchinchi. **653.** a) $2x$; b) x ; v) $\frac{x^2}{2}$ g) $\frac{x^3}{2}$. **655.** a) $3(x-1)^2$; b) $\frac{(1-x)^{1/3}}{\sqrt[3]{2}}$; v) $x-1$; g) $e(x-1)$; d) $x-1$. **656.** a) x^2 ; b) $2x^2$; v) $x^{2/3}$; g)

$x^{1/8}$ **657.** a) $\left(\frac{1}{x}\right)^3$; b) $\frac{1}{2}\left(\frac{1}{x}\right)^{1/2}$; v) $-\frac{1}{4}\left(\frac{1}{x}\right)^{3/2}$; g) $\left(\frac{1}{x}\right)^2$. **658.** a) $\frac{1}{2}\left(\frac{1}{x-1}\right)$; b) $\sqrt{x}\left(\frac{1}{1-x}\right)^{1/2}$; v) $\frac{1}{\sqrt[3]{3}}\left(\frac{1}{1-x}\right)^{1/3}$; g) $\frac{1}{p}\cdot\frac{1}{1-x}$; d) $\frac{1}{x-1}$ **663.** a) $9,95 < x < 10,05$; b) $9,995 < x < 10,005$ v) $9,9995 < x < 10,0005$; g) $\sqrt{100-e} < x < \sqrt{100+e}$. **664.** $\Delta < \frac{e}{27}$; a) $\Delta < 3,7$ mm; b) $\Delta < 0,37$ mm; v) $\Delta < 0,037$ mm. **665.** $100\left[1-10^{-(n+1)}\right]^2 < x < 100\left[1+10^{-(n+1)}\right]^2$; a) $81 < x < 121$; b) $98,01 < x < 102,01$; v) $99,8001 < x < 100,2001$; g) $99,980001 < x < 100,020001$. **666.** $d = \min\left(\frac{e}{11}, 1\right)$. **667.** $d = \frac{ex_0^2}{1+ex_0} \approx 0,001x_0^2$; a) $d \approx 10^{-5}$; b) $d \approx 10^{-7}$. v) $d \approx 10^{-9}$. Yo`q. **669.** a) Yo`q; b) ha. **671.** Yo`q; x_0 nuqtada chegaralanganlik. **672.** Yo`q; agar $f(x)$ funksiya chekli (a, b) oraliqda aniqlangan bo`lsa, u holda bu tengsizliklar doim bajariladi; agar hech bo`lmaganda a yoki $b \rightarrow \infty$ ga teng bo`lsa, u holda $\lim_{x \rightarrow \infty} |f(x)| = +\infty$. **673.** Yo`q; teskari funksiyaning bir qiymatligini va uzluksizligini. **675.** Uzluksiz. **676.** Agar $A = 4$ bo`lsa, uzluksiz, va agar $A \neq 4$ bo`lsa, $x = 2$ da uzilishga ega. **677.** $x = -1$ da uzilishga ega. **678.** a) Uzluksiz; b) $x = 0$ da uzilishga ega. **679.** $x = 0$ da uzilishga ega. **680.** Uzluksiz. **681.** Uzluksiz. **682.** $x = 1$ da uzilishga ega. **683.** $a = 0$ da uzluksiz va $a \neq 0$ da uzilishga ega. **684.** $x = 0$ da uzilishga ega. **685.** $x = k$ ($k \in \mathbb{Z}$) larda uzilishga ega. **686.** $x = k^2$ ($k = 1, 2, \dots$) da uzilishga ega. **687.** $x = -1$ - cheksiz uzilish nuqtasi. **688.** $x = -1$ - bartaraf qilinadigan uzilish nuqtasi. **689.** $x = -2$ va $x = 1$ - cheksiz uzilish nuqtalari. **690.** $x = 0$ va $x = 1$ - bartaraf qilinadigan uzilish nuqtalari, $x = -1$ - cheksiz uzilish nuqtasi. **691.** $x = 0$ - bartaraf qilinadigan uzilish nuqta; $x = kp$ ($k = \pm 1, \pm 2, \dots$) - cheksiz uzilish nuqtalari. **692.** $x = \pm 2$ - bartaraf qilinadigan uzilish nuqtalar. **693.** $x = 0$ - 2-tur uzilish nuqtasi. **694.** $x = \frac{1}{k}$ ($k = \pm 1, \pm 2, \dots$) - 1-tur uzilish nuqtalari, $x = 0$ - 2-tur uzilish nuqtasi. **695.** $x = 0$ va $x = \frac{2}{2k+1}$ ($k = 0, \pm 1, \dots$) - bartaraf qilinadigan uzilish nuqtalar. **696.** $x = 0$ - 1-tur uzilish nuqtasi. **697.** $x = 0$ - bartaraf qilinadigan uzilish nuqta. **698.** $x = 0$ - 2-tur uzilish nuqtasi. **699.** $x = 0$ - bartaraf qilinadigan uzilish nuqta, $x = 1$ - cheksiz uzilish nuqtasi. **700.** $x = 0$ - cheksiz uzilish nuqtasi, $x = 1$ - 2-tur uzilish nuqtasi. **701.** $x = kp$ ($k = 0, \pm 1, \pm 2, \dots$) - 1-tur uzilish nuqtalari. **702.** $x = k$ ($k = 0, \pm 1, \pm 2, \dots$) - 1-tur uzilish nuqtalari. **703.** $x = k$ ($k = \pm 1, \pm 2, \dots$) - 1-tur uzilish nuqtasi. **704.** Uzluksiz. **705.** $x = \pm\sqrt{n}$ ($n = 1, 2, \dots$) - 1-tur uzilish nuqtalari. **706.** $x = \frac{1}{k}$ ($k = \pm 1, \pm 2, \dots$) - 1-tur uzilish nuqtalari, $x = 0$ - cheksiz uzilish nuqtasi. **707.** $x = \frac{1}{k}$ ($k = \pm 1, \pm 2, \dots$) - 1-tur uzilish nuqtalari, $x = 0$ - bartaraf qilinadigan uzilish nuqta. **708.** $x = \frac{2}{(2k+1)p}$ ($k = 0, \pm 1, \pm 2, \dots$) - 1-tur uzilish nuqtalari, $x = 0$ - 2-tur uzilish nuqtasi. **709.** $x = \pm\frac{1}{k}$ va $x = \pm\frac{1}{\sqrt{k}}$ ($k = 1, 2, \dots$) - 1-tur uzilish nuqtalari, $x = 0$ - 2-tur uzilish nuqtasi. **710.** $x = \frac{1}{k}$ ($k = \pm 1, \pm 2, \dots$) - cheksiz uzilish nuqtalari, $x = 0$ - 2-tur uzilish nuqtasi. **711.** $x = \frac{2}{(2k+1)p}$ ($k = 0, \pm 1, \pm 2, \dots$) - cheksiz uzilish nuqtalari, $x = 0$ - 2-tur uzilish nuqtasi. **712.**

$x = \pm\sqrt{n}$ ($n = 1, 2, \dots$) - 1-tur uzilish nuqtalari. **713.** $x = 0$, $x = 1$ va $x = 2$ - 1-tur uzilish nuqtalari. **714.** $x = kp$ ($k = 0, \pm 1, \pm 2, \dots$) - cheksiz uzilish nuqtalari. **715.** $x = \pm\sqrt{kp}$ ($k = 0, 1, 2, \dots$) - cheksiz uzilish nuqtalari. **716.** $x = -1$ va $x = 3$ - cheksiz uzilish nuqtalari. **717.** $x = 0$ - 2-tur uzilish nuqtasi. **718.** $x = 0$ - cheksiz uzilish nuqtasi. **719.** $x = \pm 1$ - 1-tur uzilish nuqtalari. **720.** Agar $0 \leq x < 1$ bo`lsa, $y = 1$; agar $x = 1$ bo`lsa, $y = \frac{1}{2}$; agar $x > 1$ bo`lsa, $y = 0$; $x = 1$ - 1-tur uzilish nuqtasi. **721.** $y = \operatorname{sgn} x$; $x = 0$ - 1-tur uzilish nuqtasi. **722.** Agar $|x| \leq 1$ bo`lsa, $y = 1$; agar $|x| > 1$ bo`lsa, $y = x^2$. Funksiya uzluksiz. **723.** Agar $x \neq kp$ bo`lsa, $y = 0$; agar $x = kp$ bo`lsa, $y = 1$, ($k = 0, \pm 1, \pm 2, \dots$); $x = kp$ - 1-tur uzilish nuqtalari. **724.** Agar $|x - kp| < \frac{p}{6}$ bo`lsa, $y = x$; agar $x = kp \pm \frac{p}{6}$ bo`lsa, $y = \frac{x}{2}$; agar $\frac{p}{6} < |x - kp| < \frac{5p}{6}$ bo`lsa, $y = 0$ ($k = 0, \pm 1, \dots$); $x = kp \pm \frac{p}{6}$ - 1-tur uzilish nuqtalari. **725.** Agar $kp < x < kp + \frac{p}{2}$ bo`lsa, $y = \frac{p}{2}x$; agar $kp + \frac{p}{2} < x < kp + p$ bo`lsa, $y = -\frac{p}{2}x$; agar $x = kp \pm \frac{p}{2}$ bo`lsa, $y = 0$, ($k = 0, \pm 1, \dots$); $x = \frac{kp}{2}$ - 1-tur uzilish nuqtalari. **726.** $x \leq 0$ da $y = x$; $x > 0$ da $y = x^2$. Funksiya uzluksiz. **727.** $x \leq 0$ da $y = 0$ va $x > 0$ da $y = x$. Funksiya uzluksiz. **728.** $x < 0$ da $y = -(1+x)$; $x = 0$ da $y = 0$; $x > 0$ da $y = 1+x$; $x = 0$ - 1-tur uzilish nuqtasi. **729.** Yo`q. **730.** $a = 1$. **731.** a) Funksiya uzluksiz; b) $x = -1$ - 1-tur uzilish nuqtasi; v) $x = -1$ - 1-tur uzilish nuqtasi; g) $x = k$ ($k = 0, \pm 1, \pm 2, \dots$) - cheksiz uzilish nuqtalari; d) $x \neq k$ ($k = 0, \pm 1, \pm 2, \dots$) - 2-tur uzilish nuqtalari. **732.** $-\infty < x < 0$ da $d = -x$; $0 \leq x \leq 1$ da $d = 0$; $1 < x \leq \frac{3}{2}$ da $d = x - 1$; $\frac{3}{2} < x < 2$ da $d = 2 - x$; $2 \leq x \leq 3$ da $d = 0$; $3 < x < +\infty$ da $d = x - 3$. Funksiya uzluksiz. **733.** $0 \leq y \leq 1$ da $S = 3y - \frac{y^2}{2}$; $1 < y \leq 2$ da $S = \frac{1}{2} + 2y$; $2 < y \leq 3$ da $S = \frac{5}{2} + y$; $3 < y < +\infty$ da $S = \frac{11}{2}$; funksiya uzluksiz. $0 \leq y \leq 1$ da $b = 3 - y$; $1 < y \leq 2$ da $b = 2$; $2 < y \leq 3$ da $b = 1$; $3 < y < +\infty$ da $b = 0$; $x = 2$ va $x = 3$ - 1-tur uzilish nuqtalari. **735.** $x \neq 0$ da uzilishga ega va $x = 0$ da uzluksiz. **737.** Argumentning barcha manfiy qiymatlarida va musbat ratsional qiymatlarida uzilishga ega. **738.** $f(0) = 0,5$. **740.** a) 5; b) 2; v) 0; g) e ; d) 0; e) 1; j) 0. **741.** a) Ha; b) yo`q. **742.** a) Yo`q; b) yo`q. **743.** Yo`q. Misol: agar x - ratsional bo`lsa, $f(x) = 1$, va agar x - irratsional bo`lsa, $f(x) = -1$. **744.** a) $x = 0$ da $f(g(x))$ uzluksiz, $g(f(x))$ uzilishga ega; b) $x = -1$, $x = 0$ va $x = 1$ nuqtalarda $f(g(x))$ uzilishga ega, $g(f(x)) = 0$ uzluksiz; v) $f(g(x))$ va $g(f(x))$ funksiyalar uzluksiz. **745.** $f(j(x)) = x$. **759.** $x = \frac{-dy + b}{cy - a}$; $a + d = 0$. **760.** Agar $2k \leq y < 2k + 1$ ($k = 0, \pm 1, \pm 2, \dots$) bo`lsa, $x = y - k$. **764.** $f(f(x)) \equiv x$. **767.** $x = -\sqrt{y}$ ($0 \leq y < +\infty$); $x = \sqrt{y}$ ($0 \leq y < +\infty$). **768.** $x = 1 - \sqrt{1 - y}$ ($-\infty < y \leq 1$); $x = 1 + \sqrt{1 - y}$ ($-\infty < y \leq 1$). **769.** $x = \frac{1 - \sqrt{1 - y^2}}{y}$ ($-1 \leq y \leq 1$), $x = \frac{1 + \sqrt{1 - y^2}}{y}$ ($0 < |y| \leq 1$). **770.** $x = (-1)^k \arcsin y + kp$ ($k = 0, \pm 1, \pm 2, \dots$) ($-1 \leq y \leq 1$). **771.**

$x = 2kp \pm \arccos y$ ($k = 0, \pm 1, \dots$) ($-1 \leq y \leq 1$). **772.** $x = \operatorname{arctg} y + kp$ ($k = 0, \pm 1, \pm 2, \dots$) ($-\infty < y < +\infty$). **776.** Agar $xy < 1$ bo'lsa, $e = 0$; agar $xy > 1$ bo'lsa, $e = \operatorname{sgn} x$. **779.** a) Agar $-1 \leq x \leq 0$ bo'lsa, $y = -\frac{p}{2}$, agar $0 \leq x \leq 1$ bo'lsa, $y = 2 \arcsin x - \frac{p}{2}$; b) agar $-1 \leq x \leq -\frac{1}{\sqrt{2}}$ bo'lsa, $y = -(p + 4 \arcsin x)$; agar $-\frac{1}{\sqrt{2}} < x < \frac{1}{\sqrt{2}}$ bo'lsa, $y = 0$; agar $\frac{1}{\sqrt{2}} \leq x \leq 1$ bo'lsa, $y = p - 4 \arcsin x$. **780.** $y = \frac{p}{2} - x \left(-\frac{p}{2} < x < \frac{p}{2} \right)$. **781.** $y = \sqrt{x^2 - 1}$ ($1 \leq x < +\infty$); $y = -\sqrt{x^2 - 1}$ ($1 \leq x < +\infty$). **782.** $j(t) = x$ (bunda $x - j(t)$ funksiyaning ixtiyoriy qiymati) tenglik bajariladigan t ning barcha qiymatlari uchun $y(x)$ funksiya bir xil qiymat qabul qilishi kerak. **783.** $a < t < b$ da $c(t)$ funksiyaning qiymatlari to'plami (a, b) oraliqdan iborat bo'lishi kerak. **784.** $j(x) = u$ (bunda $u - (A, B)$ oraliqdagi ixtiyoriy son) tenglik bajariladigan x ning barcha qiymatlari uchun $y(x)$ funksiya bir xil qiymat qabul qilishi kerak. **785.** $|d| \leq \frac{e}{20}$ sm. a) 0,5 mm; b) 0,005 mm; v) 0,00005 mm. **786.** a) $d < \frac{1}{4}$; b) $d < 2,5 \cdot 10^{-4}$; v) $d < \frac{5}{2} \cdot 10^{-7}$; g) $d < \frac{e^3}{4}$ ($e \leq 1$). **793.** a) Ha; b) yo'q. **794.** Tekis uzluksiz. **795.** Tekis uzluksiz emas. **796.** Tekis uzluksiz. **797.** Tekis uzluksiz emas. **798.** Tekis uzluksiz. **799.** Tekis uzluksiz. **800.** Tekis uzluksiz emas. **802.** a) $d = \frac{e}{5}$; b) $d = \frac{e}{8}$; v) $d = 0,01e$; g) $d = e^2$ ($e \leq 1$); d) $d = \frac{e}{3}$; e) $d = \min\left(\frac{e}{3}, \frac{e^2}{3+e}\right)$. **803.** $n \geq 1\,800\,000$. **808.** a) $w_f(d) \leq 3d$; b) $w_f(d) \leq \sqrt{d}$; $w_f(d) \leq \frac{d}{\sqrt{2a}}$; v) $w_f(d) \leq d\sqrt{2}$. **818.** $f(x) = \cos ax$ yoki $f(x) = ch ax$. **819.** $f(x) = \cos ax$; $g(x) = \pm \sin ax$ ($a = \operatorname{const}$).

II-BO'LIM

821. $\Delta x = 999$; $\Delta y = 3$. **822.** $\Delta x = -0,009$; $\Delta y = 990\,000$. **823.** a) $\Delta y = a\Delta x$; b) $\Delta y = (2ax + b)\Delta x + a(\Delta x)^2$; v) $\Delta y = a^x (a^{\Delta x} - 1)$. **825.** a) 5; b) 4,1; v) 4,01; g) $4 + \Delta x$; 4. **826.** $3 + 3h + h^2$; a) 3,31; 3; b) 3,0301; v) 3,003001; 3. **827.** a) $v_{yp} = 215$ m/s; b) $v_{yp} = 210,5$ m/s; v) $v_{yp} = 210,05$ m/s; 210 m/s. **828.** a) $2x$; b) $3x^2$; v) $-\frac{1}{x^2}$ ($x \neq 0$); g) $\frac{1}{2\sqrt{x}}$ ($x > 0$); d) $\frac{1}{3\sqrt[3]{x^2}}$ ($x \neq 0$); e) $\frac{1}{\cos^2 x} \left(x \neq (2k-1)\frac{p}{2}, k = 0, \pm 1, \dots \right)$; j) $-\frac{1}{\sin^2 x}$ ($x \neq kp, k = 0, \pm 1, \dots$); z) $\frac{1}{\sqrt{1-x^2}}$ ($|x| < 1$); i) $-\frac{1}{\sqrt{1-x^2}}$ ($|x| < 1$); k) $\frac{1}{1+x^2}$. **829.** -8; 0; 0. **830.** 4. **831.** $1 + \frac{p}{4}$. **832.** $f'(a)$. **834.** $y' = 1 - 2x$; 1, 0, -1, 21. **835.** $y' = x^2 + x - 2$; a) -2; 1; b) -1; 0; v) -4; 3. **836.** $10a^3x - 5x^4$. **837.** $\frac{a}{a+b}$. **838.** $2x - (a+b)$. **839.** $2(x+2)(x+3)^2(3x^2 + 11x + 9)$. **840.** $x \sin 2a + \cos 2a$. **841.** $mn[x^{m-1} + x^{n-1} + (m+n)x^{m+n-1}]$. **842.** $-(1-x)^2(1-x^2)(1-x^3)^2(1+6x+15x^2+14x^3)$. **842.1.**

$$\begin{aligned}
& -20(17+12x)(5+2x)^9(3-4x)^{19}. \quad \mathbf{843.} \quad -\left(\frac{1}{x^2} + \frac{4}{x^3} + \frac{9}{x^4}\right) (x \neq 0). \quad \mathbf{845.} \quad \frac{2(1+x^2)}{(1-x^2)^2} (|x| \neq 1). \quad \mathbf{846.} \\
& \frac{2(1-2x)}{(1-x+x^2)^2}. \quad \mathbf{847.} \quad \frac{1-x+4x^2}{(1-x)^3(1+x)^4} (|x| \neq 1). \quad \mathbf{848.} \quad \frac{12-6x-6x^2+2x^3+5x^4-3x^5}{(1-x)^3} (x \neq 1). \quad \mathbf{849.} \\
& -\frac{(1-x)^{p-1}[(p+q)+(p-q)x]}{(1+x)^{q+1}} (x \neq -1). \quad \mathbf{850.} \quad \frac{x^{p-1}(1-x)^{q-1}}{(1+x)^2} [p-(q+1)x-(p+q-1)x^2] \\
& (x \neq -1). \quad \mathbf{851.} \quad 1 + \frac{1}{2\sqrt{x}} + \frac{1}{3\sqrt[3]{x^2}} (x > 0). \quad \mathbf{852.} \quad -\frac{1}{x^2} - \frac{1}{2x\sqrt{x}} - \frac{1}{3x\sqrt[3]{x}} (x > 0). \quad \mathbf{853.} \quad \frac{2}{3\sqrt[3]{x}} + \frac{1}{x\sqrt{x}} \\
& (x > 0). \quad \mathbf{854.} \quad \frac{1+2x^2}{\sqrt{1+x^2}}. \quad \mathbf{855.} \quad \frac{6+3x+8x^2+4x^3+2x^4+3x^5}{\sqrt{2+x^2}\sqrt[3]{(3+x^3)^2}} (x \neq \sqrt[3]{-3}). \quad \mathbf{856.} \\
& \frac{(n-m)-(n+m)x}{(n+m)^{n+m}\sqrt{(1-x)^n(1+x)^m}}. \quad \mathbf{857.} \quad \frac{a^2}{(a^2-x^2)^{3/2}} (|x| < |a|). \quad \mathbf{858.} \quad \frac{2x^2}{1-x^6}\sqrt[3]{\frac{1+x^3}{1-x^3}} (|x| \neq 1). \quad \mathbf{859.} \\
& -\frac{1}{(1+x^2)^{3/2}}. \quad \mathbf{860.} \quad \frac{1+2\sqrt{x}+4\sqrt{x}\sqrt{x+\sqrt{x}}}{8\sqrt{x}\sqrt{x+\sqrt{x}}\sqrt{x+\sqrt{x+\sqrt{x}}}} (x > 0). \quad \mathbf{861.} \quad \frac{1}{27} \cdot \frac{1}{\sqrt[3]{x^2(1+\sqrt[3]{x})^2}\sqrt[3]{(1+\sqrt[3]{1+\sqrt[3]{x}})}} \\
& (x \neq 0, x \neq -1, x \neq -8). \quad \mathbf{862.} \quad -2\cos x(1+2\sin x). \quad \mathbf{863.} \quad x^2 \sin x. \quad \mathbf{864.} \quad -\sin 2x \cdot \cos(\cos 2x). \quad \mathbf{865.} \\
& n \sin^{n-1} x \cdot \cos(n+1)x. \quad \mathbf{866.} \quad \cos x \cdot \cos(\sin x) \cdot \cos[\sin(\sin x)]. \quad \mathbf{867.} \\
& \frac{2 \sin x (\cos x \sin x^2 - x \sin x \cos x^2)}{\sin^2 x^2} (x^2 \neq kp; k=1, 2, \dots). \quad \mathbf{868.} \quad -\frac{1+\cos^2 x}{2 \sin^3 x} (x \neq kp; k \in \mathbb{Z}). \\
& \mathbf{869.} \quad \frac{n \sin x}{\cos^{n+1} x} \left(x \neq \frac{2k-1}{2} p, k \in \mathbb{Z} \right). \quad \mathbf{870.} \quad \frac{x^2}{(\cos x + x \sin x)^2}. \quad \mathbf{871.} \quad \frac{2}{\sin^2 x} (x \neq kp; k \in \mathbb{Z}). \quad \mathbf{872.} \\
& 1+tg^6 x \quad (x \neq (2k+1)\frac{p}{2}; k \in \mathbb{Z}). \quad \mathbf{873.} \quad \frac{8}{3 \sin^4 x \sqrt[3]{ctg x}} (x \neq kp, k \in \mathbb{Z}). \quad \mathbf{874.} \quad \frac{-16 \cos \frac{2x}{a}}{a \sin^3 \frac{2x}{a}} \\
& \left(x \neq \frac{kpa}{2}, k \in \mathbb{Z} \right). \quad \mathbf{875.} \quad -3tg^2 x \cdot \sec^2 x \cdot \sin(2tg^3 x) \cdot \cos[\cos^2(tg^3 x)] \left(x \neq \frac{p}{3} + kp, k \in \mathbb{Z} \right). \quad \mathbf{876.} \\
& -2xe^{-x^2}. \quad \mathbf{877.} \quad -\frac{1}{x^2} 2^{tg^{1/x}} \sec^2 \frac{1}{x} \ln 2. \quad \mathbf{878.} \quad x^2 e^x. \quad \mathbf{879.} \quad x^2 e^{-x} \sin x. \quad \mathbf{880.} \quad \frac{e^x (\sin x - \cos x)}{2 \sin^2 \frac{x}{2}} \\
& (x \neq 2kp, k \in \mathbb{Z}) \quad \mathbf{881.} \quad -\frac{1+\ln^2 3}{3^x} \sin x. \quad \mathbf{882.} \quad \sqrt{a^2+b^2} e^{ax} \sin bx. \quad \mathbf{883.} \quad e^x \left[1+e^{e^x} (1+e^{e^{e^x}}) \right]. \quad \mathbf{884.} \\
& y \left(\ln \frac{a}{b} - \frac{a-b}{x} \right) (x > 0). \quad \mathbf{885.} \quad a^a \cdot x^{a^{a-1}} + ax^{a-1} a^{x^a} \ln a + a^x \cdot a^{a^x} \ln^2 a. \quad \mathbf{886.} \quad \frac{6}{x} \lg e \lg^2 x^2 (x \neq 0). \\
& \mathbf{887.} \quad \frac{1}{x \ln x \ln(\ln x)} (x > e). \quad \mathbf{888.} \quad \frac{6}{x \ln x \ln(\ln^3 x)} (x > e). \quad \mathbf{889.} \quad \frac{1}{(1+x)^2(1+x^2)} (x > -1). \quad \mathbf{890.} \\
& \frac{x}{x^4-1} (|x| > 1). \quad \mathbf{891.} \quad \frac{1}{x(1+x^4)^2} (x \neq 0). \quad \mathbf{892.} \quad \frac{1}{3x^2-2} (|x| > \sqrt{2/3}). \quad \mathbf{893.}
\end{aligned}$$

$$\frac{2}{(1-x^2)(1-kx^2)} (|x| < 1). \quad \mathbf{894.} \quad \frac{1}{2(1+\sqrt{x+1})} (x > -1). \quad \mathbf{895.} \quad \frac{1}{\sqrt{x^2+1}}. \quad \mathbf{896.} \quad \ln(x + \sqrt{x^2+1}). \quad \mathbf{897.}$$

$$\ln^2(x + \sqrt{x^2+1}). \quad \mathbf{898.} \quad \sqrt{x^2+a^2}. \quad \mathbf{899.} \quad \frac{1}{a-bx^2} \left(|x| < \sqrt{\frac{a}{b}} \right). \quad \mathbf{900.} \quad -\frac{8}{x^5\sqrt{1-x^2}} (0 < x < 1). \quad \mathbf{901.}$$

$$\frac{1}{\sin x} (0 < x - 2kp < p, k \in Z). \quad \mathbf{902.} \quad \frac{1}{\cos x} \left(|x - 2kp| < \frac{p}{2}, k \in Z \right). \quad \mathbf{903.}$$

$$-ctg^3 x (0 < x - 2kp < p, k \in Z). \quad \mathbf{904.} \quad -\frac{1}{\cos x} \left(x \neq \frac{2k-1}{2}p, k \in Z \right). \quad \mathbf{905.} \quad \frac{\cos^2 x}{\sin^3 x}$$

$$(0 < x - 2kp < p, k \in Z). \quad \mathbf{906.} \quad \frac{\sqrt{b^2-a^2}}{a+b\cos x}. \quad \mathbf{907.} \quad -\frac{\ln^3 x}{x^2} (x > 0). \quad \mathbf{908.} \quad \frac{1}{x^5} \ln x (x > 0). \quad \mathbf{909.}$$

$$\frac{2x}{1+\sqrt[3]{1+x^2}}. \quad \mathbf{910.} \quad -\frac{1+x+\frac{1}{x}+\ln\frac{1}{x}}{\left(1+x\ln\frac{1}{x}\right)\left[1+x\ln\left(\frac{1}{x}+\ln\frac{1}{x}\right)\right]}. \quad \mathbf{911.} \quad 2\sin(\ln x) (x > 0). \quad \mathbf{912.} \quad \sin x \ln tg x$$

$$\left(0 < x - 2kp < \frac{p}{2}, k \in Z\right). \quad \mathbf{913.} \quad \frac{1}{\sqrt{4-x^2}} (|x| < 2). \quad \mathbf{914.} \quad \frac{1}{\sqrt{1+2x-x^2}} (|x-1| < \sqrt{2}). \quad \mathbf{915.} \quad \frac{2ax}{x^4+a^2}$$

$$(a \neq 0). \quad \mathbf{916.} \quad \frac{1}{x^2+2} (x \neq 0). \quad \mathbf{917.} \quad \frac{\sqrt{x}}{2(1+x)} (x \geq 0). \quad \mathbf{918.} \quad -\frac{x}{\sqrt{1-x^2}} \arccos x (|x| < 1). \quad \mathbf{919.}$$

$$\arcsin \sqrt{\frac{x}{1+x}} (x \geq 0). \quad \mathbf{920.} \quad \frac{1}{|x|\sqrt{x^2-1}} (|x| > 1). \quad \mathbf{921.} \quad \operatorname{sgn}(\cos x) \left(x \neq \frac{2k-1}{2}p, k \in Z \right). \quad \mathbf{922.}$$

$$\frac{2\operatorname{sgn}(\sin x) \cdot \cos x}{\sqrt{1+\cos^2 x}} (x \neq kp, k \in Z). \quad \mathbf{923.} \quad \frac{\sin x + \cos x}{\sqrt{\sin 2x}} \left(0 < x - kp < \frac{p}{2}, k \in Z \right). \quad \mathbf{924.} \quad \frac{\operatorname{sgn} x}{\sqrt{1-x^2}}$$

$$(0 < |x| < 1). \quad \mathbf{925.} \quad \frac{1}{1+x^2} (x \neq 1). \quad \mathbf{926.} \quad 1 \left(x \neq \frac{p}{4} + kp, k \in Z \right). \quad \mathbf{927.} \quad \frac{1}{a+b\cos x}. \quad \mathbf{928.} \quad -\frac{2\operatorname{sgn} x}{1+x^2}$$

$$(x \neq 0). \quad \mathbf{929.} \quad \frac{4x}{\sqrt{1-x^4} \arccos^3(x^2)} (|x| < 1). \quad \mathbf{930.} \quad \frac{1+x^4}{1+x^6}. \quad \mathbf{931.} \quad -2\cos x \cdot \operatorname{arctg}(\sin x). \quad \mathbf{932.}$$

$$\frac{1}{2x\sqrt{x-1} \arccos \frac{1}{\sqrt{x}}} (x > 1). \quad \mathbf{933.} \quad \frac{a^2+b^2}{(x+a)(x^2+b^2)} (x > -a). \quad \mathbf{934.} \quad \sqrt{a^2-x^2}. \quad \mathbf{935.} \quad \frac{1}{x^3+1}$$

$$(x \neq -1). \quad \mathbf{936.} \quad \frac{1}{x^4+1} (|x| \neq 1). \quad \mathbf{937.} \quad (\arcsin x)^2 (|x| < 1). \quad \mathbf{938.} \quad -\frac{\arccos x}{x^2} (0 < |x| < 1). \quad \mathbf{939.}$$

$$\frac{x \ln x}{(x^2-1)^{3/2}} (x > 1). \quad \mathbf{940.} \quad \frac{x \arcsin x}{(1-x^2)^{3/2}} (|x| < 1). \quad \mathbf{941.} \quad \frac{x^3}{x^6+1} \left(|x| \neq \frac{1}{\sqrt{2}} \right). \quad \mathbf{942.} \quad \frac{12x^5}{(1+x^{12})^2}. \quad \mathbf{943.}$$

$$-\frac{1}{(1-x)\sqrt[3]{x}} (x < 1). \quad \mathbf{944.} \quad \frac{1}{2\sqrt{1-x^2}} (|x| < 1). \quad \mathbf{945.} \quad \frac{1}{\sqrt{ax-x^2}} (0 < x < a). \quad \mathbf{946.} \quad \frac{x^2}{\sqrt{1-2x-x^2}}$$

$$(|x+1| < \sqrt{2}). \quad \mathbf{947.} \quad \frac{1}{\sqrt[4]{1+x^4}}. \quad \mathbf{948.} \quad \frac{\sin 2x}{\sin^4 x + \cos^4 x} \left(x \neq \frac{2k-1}{2}p, k \in Z \right). \quad \mathbf{949.}$$

$$\frac{\sqrt{1-x^2}}{x} - \frac{x}{\sqrt{1-x^2}} \ln \sqrt{\frac{1-x}{1+x}} (|x| < 1). \quad \mathbf{950.} \quad \frac{x^2}{1+x^2} \operatorname{arctg} x. \quad \mathbf{951.} \quad \frac{e^x}{\sqrt{1+e^{2x}}}. \quad \mathbf{952.} \quad \frac{1}{2(1+x^2)}. \quad \mathbf{953.}$$

$$\frac{\sin a \operatorname{sgn}(\cos x - \cos a)}{1 - \cos a \cos x} (\cos x \neq \cos a). \quad \mathbf{954.} \quad \frac{1}{(x^4 - 1)\sqrt{x^2 + 2}} (0 < |x| < 1). \quad \mathbf{955.} \quad \frac{\sqrt{1+x^4}}{1-x^4} (|x| \neq 1).$$

$$\mathbf{956.} \quad \frac{4}{(1+x^2)^2 \sqrt{1-x^2}} (|x| < 1). \quad \mathbf{957.} \quad \frac{2x(\cos x^2 + \sin x^2)}{\sqrt{\sin(2x^2)}} \left(0 < |x| < \sqrt{\left(k + \frac{1}{2}\right)p}, k = 0, 1, \dots \right). \quad \mathbf{958.}$$

$$2x \left[\operatorname{sgn}(\cos x^2) + \operatorname{sgn}(\sin x^2) \right] \left(|x| \neq \frac{kp}{2}, k = 0, 1, 2, \dots \right). \quad \mathbf{959.} \quad \frac{2m}{\sqrt{1-x^2}} e^{m(\arcsin x)} \cos m(\arcsin x)$$

$$(|x| < 1). \quad \mathbf{960.} \quad \frac{e^x - 1}{e^{2x} + 1}. \quad \mathbf{960.1.} \quad \frac{x^3}{6\sqrt{1+\sqrt[3]{1+\sqrt[4]{1+x^4}}} \cdot \sqrt[3]{(1+\sqrt[4]{1+x^4})^2} \cdot \sqrt[4]{(1+x^4)^3}}. \quad \mathbf{960.2.}$$

$$\frac{1}{x^3 \cos \frac{1}{x^2} \left(\sin \frac{1}{x^2} + \cos \frac{1}{x^2} \right) \sqrt{\operatorname{ctg} \frac{1}{x^2}}}. \quad \mathbf{960.3.} \quad \frac{2^{1+\sqrt[3]{x}} \ln 2 \cdot \sin(2^{\sqrt[3]{x}}) \cdot \ln(\sec 2^{\sqrt[3]{x}})}{3\sqrt[3]{x^2} \cdot \cos^2(2^{\sqrt[3]{x}})}. \quad \mathbf{961.} \quad 1 + x^x \times$$

$$\times (1 + \ln x) + x^x x^{x^x} \left(\frac{1}{x} + \ln x + \ln^2 x \right) (x > 0). \quad \mathbf{962.} \quad x^{a-1} x^{x^a} \times (1 + a \ln x) + a^x x^{a^x} \left(\frac{1}{x} + \ln a \ln x \right) +$$

$$+ x^x a^{x^x} + x^x a^{x^x} \ln a (1 + \ln x) (x > 0). \quad \mathbf{963.} \quad x^{1/x-2} (1 - \ln x) (x > 0). \quad \mathbf{964.} \quad (\sin x)^{1+\cos x} (\operatorname{ctg}^2 x -$$

$$- \ln \sin x) - (\cos x)^{1+\sin x} (\operatorname{tg}^2 x - \ln \cos x) \left(0 < x - 2kp < \frac{p}{2}, k \in \mathbb{Z} \right). \quad \mathbf{965.} \quad \frac{(\ln x)^{x-1}}{x^{\ln x+1}} [x - 2\ln^2 x + x \ln x \cdot \ln(\ln x)] (x > 1).$$

$$\mathbf{965.1.} \quad y' = 2y \left\{ \frac{\operatorname{arctg} x}{1+x^2} \ln \frac{\arcsin(\sin^2 x)}{\arccos(\cos^2 x)} + \operatorname{arctg}^2 x \left[\frac{\sin x \cdot \operatorname{sgn}(\cos x)}{\arcsin(\sin^2 x) \sqrt{1+\sin^2 x}} - \frac{\cos x \cdot \operatorname{sgn}(\sin x)}{\arccos(\cos^2 x) \sqrt{1+\cos^2 x}} \right] \right\}$$

$$\left(x \neq \frac{kp}{2}, k = 0, \pm 1, \dots \right). \quad \mathbf{966.} \quad -\frac{1}{x} (\log_x e)^2 (x > 0, x \neq 1). \quad \mathbf{967.} \quad th^3 x. \quad \mathbf{968.} \quad -\frac{2}{sh^3 x} (x > 0). \quad \mathbf{969.}$$

$$\frac{1}{ch 2x}. \quad \mathbf{970.} \quad \frac{\operatorname{sgn}(sh x)}{ch x} (x \neq 0). \quad \mathbf{971.} \quad \frac{a+bchx}{b+achx}. \quad \mathbf{972.} \quad -\frac{\sin 2x}{\sqrt{1+\cos^4 x}}. \quad \mathbf{973.}$$

$$-\frac{2}{\sqrt{1-x^2}} \arccos x \cdot \ln(\arccos x) (|x| < 1). \quad \mathbf{974.} \quad -\frac{x^{-1}}{\sqrt[4]{(1+x^4)^3}}. \quad \mathbf{975.} \quad -\frac{2xe^{-x^2} \arcsin(e^{-x^2})}{(1-e^{-2x^2})^{3/2}} (x \neq 0).$$

$$\mathbf{976.} \quad \frac{4a^{2x} \ln a}{(1+a^{2x})^2} \operatorname{arcctg} a^{-x} (a > 0). \quad \mathbf{977.} \quad \text{a) } \operatorname{sgn} x (x \neq 0); \text{ b) } 2|x|; \text{ v) } \frac{1}{x} (x \neq 0). \quad \mathbf{978.} \quad \text{a)}$$

$$(x-1)(x+1)^2 (5x-1) \operatorname{sgn}(x+1); \text{ b) } \frac{3}{2} \sin 2x \cdot |\sin x|; \text{ v) } \frac{1}{x\sqrt{x^2-1}} (|x| > 1); \text{ g) } p[x] \sin 2px.$$

$$\mathbf{979.} \quad -\infty < x < 1 \text{ da } y' = -1; 1 \leq x \leq 2 \text{ da } y' = 2x-3; 2 < x < +\infty \text{ da } y' = 1. \quad \mathbf{980.} \quad x \in [a, b] \text{ da } y' = 2(x-a)(x-b)(2x-a-b); x \in [a, b] \text{ da } y' = 0. \quad \mathbf{981.} \quad x < 0 \text{ da } y' = 1; 0 \leq x < +\infty \text{ da}$$

$$y' = \frac{1}{1+x}. \quad \mathbf{982.} \quad -1 < x \leq 1 \text{ da } y' = \frac{1}{1+x^2}; |x| > 1 \text{ da } y' = 1/2. \quad \mathbf{983.} \quad |x| \leq 1 \text{ da } y = 2xe^{-x^2} (1-x^2);$$

$$|x| > 1 \text{ da } y' = 0. \quad \mathbf{984.} \quad \text{a) } \frac{1-x-x^2}{x(1-x^2)}; \text{ b) } \frac{54-36x+4x^2+2x^3}{3x(1-x)(9-x^2)} (x \neq 0, x \neq 1, x \neq \pm 3); \text{ v) } \sum_{i=1}^n \frac{a_i}{x-a_i};$$

g) $\frac{n}{\sqrt{1+x^2}}$. **985.** a) $\frac{j(x)j'(x)+y(x)y'(x)}{\sqrt{j^2(x)+y^2(x)}} (j^2(x)+y^2(x) \neq 0)$; b) $\frac{j'(x)y(x)-j(x)y'(x)}{j^2(x)+y^2(x)}$

$(j^2(x)+y^2(x) \neq 0)$; v) $j(x)\sqrt{y(x)} \left\{ \frac{1}{j(x)} \frac{y'(x)}{y(x)} - \frac{j'(x)}{j^2(x)} \ln y(x) \right\}$; g) $\frac{y'(x)}{y(x)} \cdot \frac{1}{\ln j(x)} - \frac{j'(x)}{j(x)}$

$\cdot \frac{\ln y(x)}{\ln^2 j(x)}$. **986.** a) $2xf'(x^2)$; b) $\sin 2x [f'(\sin^2 x) - f'(\cos^2 x)]$; v) $e^{f(x)} [e^x f'(e^x) + f'(x)f(e^x)]$;

g) $f'(x) \cdot f'[f(x)] \cdot f'\{f[f(x)]\}$. **986.1.** $1000!$. **988.** $3x^2 + 15$. **989.** $6x^2$. **992.** a) $n > 0$; b)

$n > 1$; v) $n > 2$. **993.** a) $n \geq m + 1$; b) $1 < n < m + 1$. **994.** $j(a)$. **995.** $f'_-(a) = -j(a)$,

$f'_+(a) = j(a)$. **999.** a) $x = 1$ da differentsiallanuvchi emas; b) $x = \frac{2k-1}{2}p$ ($k \in Z$) da

differentsiallanuvchi emas; v) barcha nuqtalarda differentsiallanuvchi; g) $x = kp$ ($k \in Z$) da

differentsiallanuvchi emas; d) $x = -1$ da differentsiallanuvchi emas. **1000.** $x \neq 0$ da

$f'_-(x) = f'_+(x) = \operatorname{sgn} x$ va $f'_-(0) = -1$, $f'_+(0) = 1$. **1001.** x butun songa teng bo`lmaganda

$f'_-(x) = f'_+(x) = p[x] \cos px$, $f'_-(k) = p(k-1)(-1)^k$, $f'_+(k) = pk(-1)^k$ ($k \in Z$). **1002.**

$x \neq \frac{2}{2k+1}$ ($k \in Z$) $f'_-(x) = f'_+(x) = \left(\cos \frac{p}{x} + \frac{p}{x} \sin \frac{p}{x} \right) \cdot \operatorname{sgn} \left(\cos \frac{p}{x} \right)$; $f'_-\left(\frac{2}{2k+1}\right) = -(2k+1)\frac{p}{2}$,

$f'_+\left(\frac{2}{2k+1}\right) = (2k+1)\frac{p}{2}$. **1003.** $\sqrt{2kp} < |x| < \sqrt{(2k+1)p}$ ($k = 0, 1, 2, \dots$) da $f'_-(x) = f'_+(x) =$

$= \frac{x \cos x^2}{\sqrt{\sin x^2}}$; $f'_-(0) = -1$, $f'_+(0) = 1$; $f'_m(\sqrt{(2k+1)p}) = \mathbf{m}\infty$, $f'_\pm(\sqrt{2kp}) = \pm\infty$ ($k = 1, 2, \dots$).

1004. $x \neq 0$ da $f'_-(x) = f'_+(x) = \frac{1 + \left(1 + \frac{1}{x}\right)e^{1/x}}{(1 + e^{1/x})^2}$; $f'_-(0) = 1$, $f'_+(0) = 0$. **1005.** $x \neq 0$ da

$f'_-(x) = f'_+(x) = \frac{xe^{-x^2}}{\sqrt{1-e^{-x^2}}}$; $f'_-(0) = -1$, $f'_+(0) = 1$. **1006.** $f'_-(x) = f'_+(x) = \frac{e}{x}$, bunda $0 < |x| < 1$

da $e = -1$ va $1 < |x| < +\infty$ da $e = 1$, $f'_-(\mathbf{ml}) = -1$, $f'_+(\mathbf{ml}) = 1$. **1007.** $x \neq \mathbf{ml}$ da $f'_-(x) =$

$= f'_+(x) = \frac{2 \operatorname{sgn}(1-x^2)}{1+x^2}$; $f'_-(\pm 1) = \mathbf{ml}$, $f'_+(\pm 1) = \mathbf{ml}$. **1008.** $x \neq 2$ da $f'_-(x) = f'_+(x) =$

$= \operatorname{arctg} \frac{1}{x-2} - \frac{x-2}{(x-2)^2+1}$; $f'_m(2) = \mathbf{mp}/2$. **1009.1.** a) $f'_-(0) = -1/2$, $f'_+(0) = 1/2$; b) $f'_-(1) =$

$= f'_+(1) = 1/2$; v) $f'_-(0) = f'_+(0) = 0$. **1010.** $a = 2x_0$; $b = -x_0^2$. **1011.** $f'_-(x_0)$;

$b = f(x_0) - x_0 f'_-(x_0)$. **1012.** $A = \frac{k_1+k_2}{(b-a)^2}$, $c = \frac{ak_2+bk_1}{k_1+k_2}$. **1013.** $a = \frac{3m^2}{2c}$, $b = -\frac{m^2}{2c^3}$. **1014.** a)

mumkin; b) mumkin emas. **1015.** a) mumkin emas; b) mumkin emas. **1016.** a) b) v) $F(x)$ funksiya

$F'(x)$ hosilaga ega bo`lishi ham ega bo`lmasligi ham mumkin. **1017.** $x = kp$ ($k \in Z$). **1018.** a) ega

bo`lishi mumkin emas; b) ega bo`lishi mumkin. **1019.** 1) shart emas; 2) shart. **1020.** SHart emas.

1021. Yo`q kelib chiqmaydi. **1022.** Yo`q kelib chiqmaydi. **1023.** Umuman olganda mumkin emas.

$$1024. P_n = \frac{1 - (n+1)x^n + nx^{n+1}}{(1-x)^2}; \quad Q_n = \frac{1 + x - (n+1)^2 x^n + (2n^2 + 2n - 1)x^{n+1} - n^2 x^{n+2}}{(1-x)^3}. \quad 1025.$$

$$S_n = \frac{\sin \frac{nx}{2} \sin \frac{n+1}{2x}}{\sin \frac{x}{2}}; \quad T_n = \frac{n \sin \frac{x}{2} \sin \frac{2n+1}{2} x - \sin^2 \frac{nx}{2}}{2 \sin^2 \frac{x}{2}}. \quad 1025.1. \quad S_n = \frac{n \operatorname{sh} \frac{x}{2} \operatorname{sh} \left(n + \frac{1}{2} \right) x - \operatorname{sh}^2 \frac{nx}{2}}{2 \operatorname{sh}^2 \frac{x}{2}}.$$

$$1026. S_n = \frac{1}{2^n} \operatorname{ctg} \frac{x}{2^n} - \operatorname{ctg} x. \quad 1029. 40p \text{ sm}^2/\text{s}. \quad 1030. 25 \text{ m}^2/\text{s}; 0,4 \text{ m/s}. \quad 1031. 50 \text{ km/s}. \quad 1032. \text{ Agar}$$

$$0 \leq x \leq 2 \text{ bo`lsa, } S(x) = \frac{x^2}{2}; \text{ agar } x > 2 \text{ bo`lsa, } S(x) = x^2 - 2x + 2; \text{ agar } 0 \leq x \leq 2 \text{ bo`lsa,}$$

$$S'(x) = x; \text{ agar } x > 2 \text{ bo`lsa, } S'(x) = 2x - 2. \quad 1033. S(x) = \frac{|x|}{2} \sqrt{a^2 - x^2} + \frac{a^2}{2} \arcsin \frac{|x|}{a};$$

$$S'(x) = \sqrt{a^2 - x^2} \operatorname{sgn} x \quad (0 < |x| \leq a). \quad 1034. y'_x = \frac{1}{3(y^2 + 1)}. \quad 1035. y'_x = \frac{1}{1 - e \cos y}. \quad 1036. \text{ a)}$$

$$-\infty < y < +\infty, x'_y = \frac{x}{x+1}; \text{ b) } -\infty < y < +\infty, x'_y = \frac{1}{1-x+y}; \text{ v) } -\infty < y < +\infty, x'_y = \frac{1}{\sqrt{1+y^2}}; \text{ g)}$$

$$-1 < y < 1, x'_y = \frac{1}{1-y^2}. \quad 1037. \text{ a) } x_1 = -\sqrt{1+\sqrt{1-y}} \quad (-\infty < y \leq 1); \quad x_2 = -\sqrt{1-\sqrt{1-y}} \quad (0 \leq y \leq 1);$$

$$x_3 = \sqrt{1-\sqrt{1-y}} \quad (0 \leq y \leq 1); \quad x_4 = \sqrt{1+\sqrt{1-y}} \quad (-\infty < y \leq 1); \quad x'_i = \frac{1}{4x(1-x^2)} \quad (i=1, 2, 3, 4); \text{ b)}$$

$$x_1 = -\sqrt{\frac{y}{1-y}} \quad (0 \leq y < 1); \quad x_2 = \sqrt{\frac{y}{1-y}} \quad (0 \leq y < 1); \quad x'_i = \frac{x^3}{2y^2} \quad (i=1, 2); \text{ v) } x_1 = -\ln(1+\sqrt{1-y})$$

$$(-\infty < y \leq 1); \quad x_2 = \ln \frac{1+\sqrt{1-y}}{y} \quad (0 < y \leq 1); \quad x'_i = -\frac{1}{2(e^{-x} - e^{-2x})} \quad (i=1, 2). \quad 1038. y'_x = -\frac{3}{2}(1+t);$$

$$-3; \quad -\frac{3}{2}, \text{ va } -\frac{9}{2}; \quad (-4; 4). \quad 1039. \sqrt[6]{\frac{(1-\sqrt{t})^4}{t(1-\sqrt[3]{t})^3}} \quad (t > 0, t \neq 1). \quad 1040. y'_x = -1 \quad (0 < x < 1). \quad 1041.$$

$$y'_x = -\frac{b}{a} \operatorname{ctg} t \quad (0 < |t| < p). \quad 1042. y'_x = \frac{b}{a} \operatorname{ctg} t \quad (|t| > 0). \quad 1043. y'_x = -\operatorname{tg} t \left(t \neq \frac{2k+1}{2} p, k \in Z \right).$$

$$1044. y'_x = \operatorname{ctg} \frac{t}{2} \quad (t \neq 2kp, k \in Z). \quad 1045. y'_x = \operatorname{tg} t \cdot g \left(t + \frac{p}{4} \right) \left(t \neq \frac{p}{4} + kp, t \neq \frac{p}{2} + kp \right). \quad 1046.$$

$$y'_x = \operatorname{sgn} t \quad (0 < |t| < +\infty). \quad 1048. y' = \frac{1-x-y}{x-y}; \quad \frac{3}{2}, \quad -\frac{1}{2}. \quad 1049. \frac{p}{y}. \quad 1050. -\frac{b^2 x}{a^2 y}. \quad 1051. -\sqrt{\frac{y}{x}} ..$$

$$1052. -\sqrt[3]{\frac{y}{x}}. \quad 1053. \frac{x+y}{x-y}. \quad 1054. \text{ a) } \operatorname{tg}(j + \operatorname{arctg} j); \text{ b) } -\operatorname{ctg} \frac{3j}{2} \left(j \neq 0, j \neq \pm \frac{2p}{3} \right); \text{ v)}$$

$$\operatorname{tg} \left(j + \operatorname{arctg} \frac{1}{m} \right). \quad 1055. \text{ a) } y = \sqrt[3]{4}(x+1); \quad y = -\frac{\sqrt[3]{2}}{2}(x+1); \text{ b) } y = 3, \quad x = 2; \text{ v) } x = 3, \quad y = 0..$$

$$1056. \text{ a) } \left(\frac{1}{2}, 2\frac{1}{4} \right); \text{ b) } (0, 2). \quad 1058. |x| < \frac{p}{3} \text{ va } \frac{2p}{3} < |x| \leq p. \quad 1059. \max |y'_1 - y'| = 10p \approx 31,4.$$

1060. $\frac{p}{4}$. **1061.** $\frac{p}{2}$; $\operatorname{arctg} \frac{3}{4} \approx \operatorname{arc} 37^\circ$. **1062.** $\operatorname{arctg} 2\sqrt{2} \approx \operatorname{arc} 70^\circ 30'$. **1063.** $n > 57,3$. **1064.** a) $2 \operatorname{arctg} \frac{1}{|a|}$; b) $\frac{p}{2}$. **1066.** $\left| \frac{x}{n} \right|$. **1069.** $\frac{y_0^2}{|a|}$. **1071.** $b^2 - 4ac = 0$. **1072.** $\left(\frac{p}{3} \right)^3 + \left(\frac{q}{2} \right)^2 = 0$. **1073.** $a = \frac{1}{2e}$. **1077.** a) $3x - 2y = 0$, $2x + 3y = 0$; b) $3x - y - 1 = 0$, $x + 3y - 7 = 0$. **1078.** a) $y = x$, $y = -x$; b) $3x - y - 4 = 0$, $x + 3y - 3 = 0$; v) $y = -x$, $y = x$. **1079.** $y - 2a = (x - at_0) \operatorname{ctg} \frac{t_0}{2}$. **1081.** $3x + 5y - 50 = 0$, $5x - 3y - 10,8 = 0$. **1082.** $x + 2y - 3 = 0$, $2x - y - 1 = 0$. **1083.** $\Delta f(1) = \Delta x + 3(\Delta x)^2 + (\Delta x)^3$; $df(1) = \Delta x$. a) 5, 1; b) 0,131, 0,1; v) 0,010301, 0,01. **1084.** $\Delta x = 20\Delta t + 5(\Delta t)^2$, $dx = 20\Delta t$; a) 25 m, 20 m; b) 2,05 m, 2 m; v) 0,020005 m, 0,02 m. **1085.** $-\frac{dx}{x^2}$ ($x \neq 0$). **1086.** $\frac{dx}{a^2 + x^2}$. **1087.** $\frac{dx}{x^2 - a^2}$ ($|x| \neq |a|$). **1088.** $\frac{dx}{\sqrt{x^2 + a}}$. **1089.** $\frac{\operatorname{sgn} a}{\sqrt{a^2 - x^2}} dx$ ($|x| < |a|$). **1090.** a) $(1+x)e^x dx$; b) $x \sin x dx$; v) $-\frac{3dx}{x^4}$ ($x \neq 0$); g) $\frac{2 - \ln x}{2x\sqrt{x}} dx$ ($x > 0$); d) $\frac{x dx}{\sqrt{a^2 + x^2}}$; e) $\frac{dx}{(1-x^2)^{3/2}}$ ($|x| < 1$); j) $-\frac{2x dx}{1-x^2}$ ($|x| < 1$); z) $\frac{dx}{x\sqrt{x^2 - 1}}$ ($|x| > 1$); i) $\frac{dx}{\cos^3 x} \left(x \neq \frac{p}{2} + kp, k \in Z \right)$. **1091.** $vw du + uw dv + uv dw$. **1092.** $\frac{v du - 2u dv}{v^3}$ ($v \neq 0$). **1093.** $-\frac{u du + v dv}{(u^2 + v^2)^{3/2}}$ ($u^2 + v^2 > 0$). **1094.** $\frac{v du - u dv}{u^2 + v^2}$ ($u^2 + v^2 > 0$). **1095.** $\frac{u du + u dv}{u^2 + v^2}$ ($u^2 + v^2 > 0$). **1096.** a) $1 - 4x^3 - 3x^6$; b) $\frac{1}{2x^2} \left(\cos x - \frac{\sin x}{x} \right)$; v) $-\operatorname{ctg} x$ ($x \neq kp, k \in Z$); g) $-tg^2 x$ ($x \neq \frac{p}{2} + kp, k \in Z$); d) -1 ($|x| < 1$). **1097.** a) 104,7 sm^2 ga ortadi; b) 43,6 sm^2 ga kamayadi. **1098.** 2,23 sm ga orttiring. **1099.** 1,007 (jadval bo'yicha 1,0066). **1100.** 0,4849 (jadval bo'yicha 0,4848). **1101.** -0,8747 (jadval bo'yicha -0,8746). **1102.** 0,8104 = $\operatorname{arc} 46^\circ 26'$ (jadval bo'yicha $\operatorname{arc} 46^\circ 24'$). **1103.** 1,043 (jadval bo'yicha 1,041). **1104.** a) 2,25 (jadval bo'yicha 2,24); b) 5,833 (jadval bo'yicha 5,831); v) 10,9546 (jadval bo'yicha 10,9545). **1105.** a) 2,083 (jadval bo'yicha 2,080); b) 2,9907 (jadval bo'yicha 2,9907); v) 1,938 (jadval bo'yicha 1,931); g) 1,9954 (jadval bo'yicha 1,9953). **1106.** 0,24 m^2 ; 4,2 %. **1107.** $d_R \leq 0,33\%$. **1108.** a) $d_g = d_i$; b) $d_g = 2d_T$. **1109.** 0,43d. **1111.** $\frac{x(3+2x^2)}{(1+x^2)^{3/2}}$. **1112.** $\frac{3x}{(1-x^2)^{5/2}}$ ($|x| < 1$). **1113.** $2e^{-x^2}(2x^2 - 1)$. **1114.** $\frac{2 \sin x}{\cos^3 x} \left(x \neq \frac{2k+1}{2}p, k \in Z \right)$. **1115.** $\frac{2x}{1+x^2} + 2 \operatorname{arctg} x$. **1116.** $\frac{3x}{(1-x^2)^2} + \frac{(1+2x^2) \operatorname{arcsin} x}{(1-x^2)^{5/2}}$ ($|x| < 1$). **1117.** $\frac{1}{x}$ ($x > 0$). **1118.** $\frac{f(x)f''(x) - f'^2(x)}{f^2(x)}$ ($f(x) > 0$). **1119.** $-\frac{2}{x} \sin(\ln x)$ ($x > 0$). **1120.** $y(0) = 1$, $y'(0) = 1$, $y''(0) = 0$. **1121.** $2(uu'' + u'^2)$. **1122.** $\frac{uu'' - u'^2}{u^2} - \frac{vv'' - v'^2}{v^2}$ ($uv > 0$).

$$1123. \frac{(u^2 + v^2)(uu'' + vv'') + (u'v - uv')^2}{(u^2 + v^2)^{3/2}} \quad (u^2 + v^2 > 0).$$

$$1124. y'' = u^v \left[\left(v \frac{u}{u'} + v' \ln u \right)^2 + v \frac{uu'' - v'^2}{u^2} + \frac{2u'v'}{u} + u'' \ln u \right]. \quad 1125. y'' = 4x^2 f''(x^2) + 2f'(x^2);$$

$$y''' = 8x^3 f'''(x^2) + 12xf''(x^2). \quad 1126. y'' = \frac{1}{x^4} f''\left(\frac{1}{x}\right) + \frac{2}{x^3} f'\left(\frac{1}{x}\right); \quad y''' = -\frac{1}{x^6} f'''\left(\frac{1}{x}\right) - \frac{6}{x^5} f''\left(\frac{1}{x}\right) - \frac{6}{x^4} f'\left(\frac{1}{x}\right).$$

$$1127. y'' = e^{2x} f''(e^x) + e^x f'(e^x); \quad y''' = e^{3x} f'''(e^x) + 3e^{2x} f''(e^x) + e^x f'(e^x). \quad 1128. y'' = \frac{1}{x^2} [f''(\ln x) - f'(\ln x)]; \quad y''' = \frac{1}{x^3} [f'''(\ln x) - 3f''(\ln x) + 2f'(\ln x)]. \quad 1129.$$

$$y'' = j'^2(x) f''(j(x)) + j''(x) f'(j(x)); \quad y''' = j'^3(x) f'''(j(x)) + 3j'(x) j''(x) f''(j(x)) + j''(x) f'(j(x)).$$

$$1130. a) e^x dx^2; \quad b) e^x (dx^2 + d^2x). \quad 1131. \frac{dx^2}{(1+x^2)^{3/2}}. \quad 1132. \frac{2 \ln x - 3}{x^3} dx^2$$

$$(x > 0). \quad 1133. x^x \left[(1 + \ln x)^2 + \frac{1}{x} \right] dx^2. \quad 1134. ud^2v + 2dudv + vd^2u. \quad 1135.$$

$$\frac{(vd^2u - ud^2v) - 2dv(vdu - udv)}{1} \quad (v > 0). \quad 1136. u^{m-2} v^{n-2} \{ [m(m-1)v^2 du^2 + 2mnuvdudv +$$

$$+ n(n-1)u^2 dv^2] + uv(mvd^2u + nud^2v) \}. \quad 1137. a^u \ln a (du^2 \ln a + d^2u). \quad 1138.$$

$$\left[(v^2 - u^2) du^2 - 4uvdudv + (u^2 - v^2) dv^2 + (u^2 + v^2)(ud^2u + vd^2v) \right] (u^2 + v^2)^{-2} \quad (u^2 + v^2 > 0).$$

$$1139. \left[-2uvdu^2 + 2(u^2 - v^2)dudv + 2uvdv^2 + (u^2 + v^2)(vd^2u - ud^2v) \right] (u^2 + v^2)^{-2} \quad (u^2 + v^2 > 0).$$

$$1140. y'' = \frac{3}{4(1-t)}; \quad y''' = \frac{3}{8(1-t)^3} \quad (t \neq 1). \quad 1141. y'' = -\frac{1}{a \sin^3 t}; \quad y''' = -\frac{3 \cos t}{a^2 \sin^5 t} \quad (t \neq kp, k \in Z).$$

$$1142. y'' = -\frac{1}{4a \sin^4 \frac{t}{2}}; \quad y''' = \frac{\cos \frac{t}{2}}{4a^2 \sin^7 \frac{t}{2}} \quad (t \neq 2kp, k \in Z). \quad 1143. y'' = \frac{e^{-t}}{\sqrt{2} \cos^3 \left(t + \frac{p}{4} \right)};$$

$$y''' = \frac{e^{-2t} (2 \sin t + \cos t)}{\sqrt{2} \cos^5 \left(t + \frac{p}{4} \right)} \left(t \neq \frac{p}{4} + kp, k \in Z \right). \quad 1144. y'' = \frac{1}{f''(t)}; \quad y''' = -\frac{f'''(t)}{f''^3(t)} \quad (f''(t) \neq 0).$$

$$1145. x' = \frac{1}{y'}; \quad x'' = -\frac{y''}{y'^3}; \quad x''' = -\frac{y'y''' - 3y''^2}{y'^5}; \quad x^{IV} = -\frac{y'^2 y^{IV} - 10y'y''y''' + 15y''^3}{y'^7} \quad (y' \neq 0). \quad 1146.$$

$$-\frac{x}{y}, \quad -\frac{25}{y^3}, \quad -\frac{75x}{y^5}; \quad -\frac{3}{4}, \quad -\frac{25}{64}, \quad -\frac{225}{1024}. \quad 1147. \frac{p}{y}, \quad -\frac{p^2}{y^3}, \quad \frac{3p^3}{y^5}. \quad 1148. y' = \frac{2x-y}{x-2y},$$

$$y'' = \frac{6}{(x-2y)^3}, \quad y''' = \frac{54x}{(x-2y)^5}. \quad 1149. y' = \frac{2x^3 y}{1+y^2}; \quad y'' = \frac{2x^2 y}{(1+y^2)^3} \left[3(1+y^2)^2 + 2x^4(1-y^2) \right].$$

$$1150. y' = \frac{x+y}{x-y}; \quad y'' = \frac{2(x^2+y^2)}{(x-y)^3}. \quad 1151. a = \frac{1}{2} f''(x_0); \quad b = f'(x_0); \quad c = f(x_0). \quad 1152. 20-10t,$$

-10; 0, -10. **1153.** $v = -\frac{2pa}{T} \sin \frac{2p}{T} t$, $j = -\frac{4p^2 a}{T^2} \cos \frac{2p}{T} t$. **1154.** $x = v_0 t \cos a$, $y = v_0 t \sin a - \frac{gt^2}{2}$;

$v = \sqrt{v_0^2 - 2v_0 g t \sin a + g^2 t^2}$; $j = g$; $y = x \operatorname{tg} a - \frac{gx^2}{2v_0^2 \cos^2 a}$; $\frac{v_0^2 \sin^2 a}{2g}$; $\frac{v_0^2}{g} \sin 2a$. **1155.**

$x^2 + y^2 = 25$; $5|w|$, $5w^2$. **1156.** $y^{(6)} = 4 \cdot 6!$; $y^{(7)} = 0$. **1157.** $y''' = -\frac{am(m+1)(m+2)}{x^{m+3}}$ ($x \neq 0$).

1158. $y^{(10)} = -\frac{17!!}{2^{10} x^9 \sqrt{x}}$ ($x > 0$), bunda $17!! = 1 \cdot 3 \cdot 5 \dots 17$. **1159.** $y^{(8)} = \frac{8!}{(1-x)^9}$ ($x \neq 1$). **1160.**

$y^{(100)} = \frac{197!!(399-x)}{2^{100}(1-x)^{100} \sqrt{1-x}}$ ($x < 1$). **1161.** $y^{(20)} = 2^{20} e^{2x} (x^2 + 20x + 95)$. **1162.** $y^{(10)} = e^x \sum_{i=1}^{10} (-1)^i \frac{A_{10}^i}{x^{i+1}}$

bunda $A_{10}^i = 10 \cdot 9 \cdot \dots (11-i)$ va $A_{10}^0 = 1$. **1163.** $y^{(5)} = -\frac{6}{x^4}$ ($x > 0$). **1164.** $y^{(5)} = \frac{274}{x^6} - \frac{120}{x^6} \ln x$

($x > 0$). **1165.** $y^{(50)} = 2^{50} \left(-x^2 \sin 2x + 50x \cos 2x + \frac{1225}{2} \sin 2x \right)$. **1166.**

$y''' = \frac{27(1-3x)^2 - 36}{(1-3x)^{7/3}} \sin 3x - \frac{27(1-3x)^2 - 28}{(1-3x)^{10/3}} \cos 3x$ ($x \neq \frac{1}{3}$). **1167.**

$y^{(10)} = -2^8 \sin 2x - 2^{18} \sin 4x + 2^8 \cdot 3^{10} \sin 6x$. **1168.** $y^{(100)} = x \operatorname{sh} x + 100 \operatorname{ch} x$. **1169.** $y^{IV} = -4e^x \cos x$.

1170. $y^{(6)} = -\frac{60}{x^6} + \left(\frac{144}{x^5} - \frac{160}{x^3} - \frac{96}{x} \right) \sin 2x + \left(\frac{60}{x^6} - \frac{180}{x^4} + \frac{120}{x^2} + 32 \ln x \right) \cos 2x$. **1171.** $120dx^5$.

1172. $-\frac{15}{8x^3 \sqrt{x}} dx^3$ ($x > 0$). **1173.** $-1024(x \cos 2x + 5 \sin 2x) dx^{10}$. **1174.**

$e^x \left(\ln x + \frac{4}{x} - \frac{6}{x^2} + \frac{8}{x^3} - \frac{6}{x^4} \right) dx^4$. **1175.** $8 \sin x \operatorname{sh} x dx^6$. **1176.** $2ud^{10}u + 20dud^9u + 90d^2ud^8u +$

$+240d^3ud^7u + 420d^4ud^6u + 252(d^2u)^2$. **1177.** $e^u (du^4 + 6du^2 d^2u + 4dud^3u + 3d^2u^2 + d^4u)$. **1178.**

$\frac{2du^2}{u^3} - \frac{3dud^2u}{u^2} + \frac{d^3u}{u}$. **1179.** $d^2y = y''dx^2 + y'd^2x$; $d^3y = y'''dx^3 + 3y''dxd^2x + y'd^3x$;

$d^4y = y^{IV}dx^4 + 6y'''dx^2d^2x + 4y''dxd^3x + 3y''d^2x^2 + y'd^4x$.

1180. $y'' = \frac{\begin{vmatrix} dx & dy \\ d^2x & d^2y \end{vmatrix}}{d^3x}$; $y''' = \frac{dx \begin{vmatrix} dx & dy \\ d^3x & d^3y \end{vmatrix} - 3d^2x \begin{vmatrix} dx & dy \\ d^2x & d^2y \end{vmatrix}}{dx^5}$. **1187.** $P^{(n)}(x) = a_0 n!$. **1188.**

$\frac{(-1)^{n-1} n! c^{n-1} (ad-bc)}{(cx+d)^{n+1}}$. **1189.** $n! \left[\frac{(-1)^n}{x^{n+1}} + \frac{1}{(1-x)^{n+1}} \right]$. **1190.** $(-1)^n n! \left[\frac{1}{(x-2)^{n+1}} - \frac{1}{(x-1)^{n+1}} \right]$.

1191. $\frac{1 \cdot 3 \dots (2n-1)}{(1-2x)^{n+1/2}}$ ($x < \frac{1}{2}$). **1192.** $\frac{(-1)^{n+1} \cdot 1 \cdot 4 \dots (3n-5)(3n+2x)}{3^n (1+x)^{n+1/3}}$ ($n \geq 2$; $x \neq -1$). **1193.**

$-2^{n-1} \cos \left(2x + \frac{np}{2} \right)$. **1194.** $2^{n-1} \cos \left(2x + \frac{np}{2} \right)$. **1195.** $\frac{3}{4} \sin \left(x + \frac{np}{2} \right) - \frac{3^n}{4} \sin \left(3x + \frac{np}{2} \right)$. **1196.**

$\frac{3}{4} \cos \left(x + \frac{np}{2} \right) + \frac{3^n}{4} \cos \left(3x + \frac{np}{2} \right)$. **1197.** $\frac{(a-b)^n}{2} \cos \left[(a-b)x + \frac{np}{2} \right] - \frac{(a+b)^n}{2} \times$

$$\times \cos \left[(a+b)x + \frac{np}{2} \right]. \quad \mathbf{1198.} \quad \frac{(a-b)^n}{2} \cos \left[(a-b)x + \frac{np}{2} \right] + \frac{(a+b)^n}{2} \cos \left[(a+b)x + \frac{np}{2} \right]. \quad \mathbf{1199.}$$

$$\frac{(a-b)^n}{2} \sin \left[(a-b)x + \frac{np}{2} \right] + \frac{(a+b)^n}{2} \sin \left[(a+b)x + \frac{np}{2} \right]. \quad \mathbf{1200.} \quad \frac{b^n}{2} \cos \left(bx + \frac{np}{2} \right) - \frac{(2a-b)^n}{4} \times$$

$$\times \cos \left[(2a-b)x + \frac{np}{2} \right] - \frac{(2a+b)^n}{4} \cos \left[(2a+b)x + \frac{np}{2} \right]. \quad \mathbf{1201.} \quad 4^{n-1} \cos \left(4x + \frac{np}{2} \right). \quad \mathbf{1202.}$$

$$a^n x \cos \left(ax + \frac{np}{2} \right) + na^{n-1} \sin \left(ax + \frac{np}{2} \right). \quad \mathbf{1203.} \quad a^n \left[x^2 - \frac{n(n-1)}{a^2} \right] \sin \left(ax + \frac{np}{2} \right) - 2na^{n-1} x \times$$

$$\times \cos \left(ax + \frac{np}{2} \right) \quad \mathbf{1204.} \quad (-1)^n e^{-x} \left[x^2 - 2(n-1)x + (n-1)(n-2) \right]. \quad \mathbf{1205.}$$

$$e^x \left\{ \frac{1}{x} + \sum_{k=1}^n (-1)^k \frac{n(n-1) \dots (n-k+1)}{x^{k+1}} \right\}. \quad \mathbf{1206.} \quad e^x 2^{n/2} \cos \left(x + \frac{np}{4} \right). \quad \mathbf{1207.} \quad e^x 2^{n/2} \sin \left(x + \frac{np}{4} \right).$$

$$\mathbf{1208.} \quad \frac{(n-1)! b^n}{(a^2 - b^2 x^2)^n} \left[(a+bx)^n + (-1)^{n-1} (a+bx)^n \right] \left(|x| < \left| \frac{a}{b} \right| \right). \quad \mathbf{1209.} \quad e^{ax} [a^n P(x) + C_n^1 a^{n-1} P'(x) + \dots$$

$$\dots + P^{(n)}(x)]. \quad \mathbf{1210.} \quad \frac{1}{2} \left\{ [(x+n) - (-1)^n (x-n)] ch x + [(x+n) + (-1)^n (x-n)] sh x \right\}. \quad \mathbf{1211.} \quad d^n y =$$

$$= e^x \left[x^n + n^2 x^{n-1} + \frac{n^2 (n-1)^2}{2!} x^{n-2} + \dots + n! \right] dx^n. \quad \mathbf{1212.} \quad \frac{(-1)^n n!}{x^{n+1}} \left\{ \ln x - \sum_{i=1}^n \frac{1}{i} \right\} dx^n \quad (x > 0).$$

$$\mathbf{1214.} \quad \text{a) } (a^2 + b^2)^{n/2} \left[\cos \left(nj - \frac{np}{2} \right) ch ax \cos \left(bx + \frac{np}{2} \right) - \sin \left(nj - \frac{np}{2} \right) sh ax \sin \left(bx + \frac{np}{2} \right) \right]; \quad \text{b)}$$

$$(a^2 + b^2)^{n/2} \left[\cos \left(nj - \frac{np}{2} \right) ch ax \sin \left(bx + \frac{pn}{2} \right) + \sin \left(nj - \frac{np}{2} \right) sh ax \cos \left(bx + \frac{np}{2} \right) \right], \quad \text{bunda}$$

$$\cos j = \frac{a}{\sqrt{a^2 + b^2}}, \quad \sin j = \frac{b}{\sqrt{a^2 + b^2}}. \quad \mathbf{1215.} \quad f^{(n)}(x) = \sum_{k=0}^{p-1} (-1)^{p+k} 2^{n-2p+1} (p-k)^n C_{2p}^k \times$$

$$\times \cos \left[(2p-2k)x + \frac{np}{2} \right]. \quad \mathbf{1216.} \quad \text{a) } \sum_{k=0}^p (-1)^{p+k} \frac{(2p-2k+1)^n}{2^{2p}} C_{2p+1}^k \sin \left[(2p-2k+1)x + \frac{np}{2} \right]; \quad \text{b)}$$

$$\sum_{k=0}^{p-1} 2^{n-2p+1} (p-k)^n C_{2p}^k \cos \left[(2p-2k)x + \frac{np}{2} \right]; \quad \text{v) } \sum_{k=0}^p \left\{ \frac{(2p-2k+1)^n}{2^{2p}} C_{2p+1}^k \cos \left[(2p-2k+1)x + \frac{np}{2} \right] \right\}.$$

$$\mathbf{1218.} \quad \frac{(-1)^{n-1} (n-1)!}{(1+x^2)^{n/2}} \sin(n \operatorname{arctg} x) \quad (x \neq 0). \quad \mathbf{1219.} \quad \text{a) } \frac{n!}{3} [2^{n+1} + (-1)^n]; \quad \text{b) } \frac{n(2n-3)!!}{2^{n-1}} \quad (n > 1).$$

$$\mathbf{1220.} \quad \text{a) } n(n-1)a^{n-2}; \quad \text{b) } f^{(2k)}(0) = 0, \quad f^{(2k+1)}(0) = (-1)^k (2k!) \quad (k = 0, 1, 2, \dots); \quad \text{v) } f^{(2k)}(0) = 0,$$

$$f^{(2k+1)}(0) = [1 \cdot 3 \dots (2k-1)]^2 \quad (k = 0, 1, 2, \dots). \quad \mathbf{1221.} \quad \text{a) } f^{(2k)}(0) = (-1)^k m^2 (m^2 - 2^2) \dots \times$$

$$\times [m^2 - (2k-2)^2], \quad f^{(2k-1)}(0) = 0; \quad \text{b) } f^{(2k)}(0) = 0, \quad f'(0) = m, \quad f^{(2k+1)}(0) = (-1)^k m(m^2 - 1^2) \dots \times$$

$$\times [m^2 - (2k-1)^2] \quad (k = 1, 2, \dots). \quad \mathbf{1222.} \quad \text{a) } f^{(2k)}(0) = (-1)^{k-1} \cdot 2(2k-1)! \left(1 + \frac{1}{3} + \dots + \frac{1}{2k-1} \right),$$

$$f^{(2k-1)}(0) = 0 \quad (k = 1, 2, \dots); \quad \text{b) } f^{(2k)}(0) = 2^{2k-1} [(k-1)!]^2, \quad f^{(2k-1)}(0) = 0 \quad (k = 1, 2, \dots). \quad \mathbf{1223.}$$

$n!j(a)$. **1228.** $L_m(x) = (-1)^m \left[x^m - m^2 x^{m-1} + \frac{m^2(m-1)^2}{1 \cdot 2} x^{m-2} + \dots + (-1)^m m! \right]$. **1231.** $H_m(x) = (2x)^m - \frac{m(m-1)}{1!} (2x)^{m-2} + \frac{m(m-1)(m-2) \cdot (m-3)}{2!} (2x)^{m-4} - \dots$ **1236.** $x=0$ da chekli $f'(x)$ hosila mavjud emas. **1244.** $A(-1, -1)$, $C(1, 1)$. **1245.** Yo`q. **1246.** a) $q=1/2$; b) $q = \frac{\sqrt{x^2 + x\Delta x + \frac{1}{3}(\Delta x)^2} - x}{\Delta x}$ ($x \geq 0, \Delta x > 0$); v) $q = \frac{x}{\Delta x} \left(\sqrt{1 + \frac{\Delta x}{x}} - 1 \right)$ ($x(x + \Delta x) > 0$); g) $q = \frac{1}{\Delta x} \ln \frac{e^{\Delta x} - 1}{\Delta x}$. **1248.** $c = \frac{1}{2}$ yoki $\sqrt{2}$. **1250.** Umuman olganda yo`q. **1261.** $f(x) = c_0 + c_1 x + \dots + c_{n-1} x^{n-1}$, bunda c_i ($i=0, 1, \dots, n-1$) o`zgarmas sonlar. **1268.** $-\infty < x < \frac{1}{2}$ da funksiya o`sadi, $\frac{1}{2} < x < +\infty$ da kamayadi. **1269.** $-\infty < x < -1$ da funksiya kamayadi, $-1 < x < 1$ da o`sadi; $1 < x < +\infty$ da kamayadi. **1270.** $-\infty < x < -1$ da funksiya kamayadi, $-1 < x < 1$ da funksiya o`sadi, $1 < x < +\infty$ da kamayadi. **1271.** $0 < x < 100$ da funksiya o`sadi, $100 < x < +\infty$ da kamayadi. **1272.** Funksiya o`suvchi. **1273.** $\left(\frac{kp}{2}, \frac{kp}{2} + \frac{p}{3} \right)$ oraliqlarda funksiya o`suvchi; $\left(\frac{kp}{2} + \frac{p}{3}, \frac{kp}{2} + \frac{p}{2} \right)$ oraliqlarda kamayuvchi ($k=0, \pm 1, \pm 2, \dots$). **1274.** $\left(\frac{1}{2k+1}, \frac{1}{2k} \right)$ va $\left(-\frac{1}{2k+1}, -\frac{1}{2k+2} \right)$ oraliqlarda funksiya o`suvchi; $\left(\frac{1}{2k+2}, \frac{1}{2k+1} \right)$ va $\left(-\frac{1}{2k}, -\frac{1}{2k+1} \right)$ oraliqlarda kamayuvchi ($k=0, 1, 2, \dots$). **1275.** $-\infty < x < 0$ da funksiya kamayadi, $0 < x < \frac{2}{\ln 2}$ da funksiya o`sadi; $\frac{2}{\ln 2} < x < +\infty$ da kamayadi. **1276.** $0 < x < n$ da funksiya o`suvchi; $n < x < +\infty$ da funksiya kamayuvchi. **1277.** $-\infty < x < -1$ va $0 < x < 1$ da kamayuvchi; $-1 < x < 0$ va $1 < x < +\infty$ da o`suvchi. **1278.** $(e^{-7p/12+2kp}, e^{13p/12+2kp})$ oraliqlarda o`suvchi; $(e^{13p/12+2kp}, e^{17p/12+2kp})$ oraliqlarda kamayuvchi ($k=0, \pm 1, \pm 2, \dots$). **1283.** SHart emas. **1298.** A nuqtada yuqoriga qavariq; B nuqtada quyiga qavariq; C –egilish nuqtasi. **1299.** $-\infty < x < 1$ da grafik yuqoriga qavariq; $1 < x < +\infty$ da quyiga qavariq, $x=1$ –egilish nuqtasi. **1300.** $|x| < \frac{a}{\sqrt{3}}$ da quyiga qavariq; $|x| > \frac{a}{\sqrt{3}}$ da yuqoriga qavariq, $x = \pm \frac{a}{\sqrt{3}}$ –egilish nuqtalari. **1301.** $x < 0$ da quyiga qavariq; $x > 0$ da yuqoriga qavariq, $x=0$ –egilish nuqtasi. **1302.** YUqoriga qavariq. **1303.** $2kp < x < (2k+1)p$ da quyiga qavariq; $(2k+1)p < x < (2k+2)p$ da yuqoriga qavariq; $x=kp$ –egilish nuqtalari ($k=0, \pm 1, \pm 2, \dots$). **1304.** $|x| < \sqrt{1/2}$ da quyiga qavariq; $|x| > \sqrt{1/2}$ da yuqoriga qavariq; $x = \pm \sqrt{1/2}$ –egilish nuqtalari. **1305.** $|x| < 1$ da yuqoriga qavariq; $|x| > 1$ da quyiga qavariq; $x = \pm 1$ –egilish nuqtalari. **1306.** $e^{2kp-3p/4} < x < e^{2kp+p/4}$ da yuqoriga qavariq; $e^{2kp+p/4} < x < e^{2kp+5p/4}$ da quyiga qavariq; $x = e^{kp+p/4}$ –egilish nuqtalari ($k=0, \pm 1, \pm 2, \dots$). **1307.** $0 < x < +\infty$ da yuqoriga qavariq. **1309.** $h = \frac{1}{s\sqrt{2}}$. **1310.** Quyiga qavariq ($a > 0$ da). **1318.** $\frac{a}{b}$. **1319.** 1. **1320.** 2.

1321. -2. **1322.** $\frac{1}{3}$. **1323.** $-\frac{1}{3}$. **1324.** $\frac{1}{3}$. **1325.** $\frac{1}{6}$. **1326.** $\frac{1}{2}$. **1327.** 1. **1328.** $\frac{a-b}{3ab}$. **1329.** $\frac{1}{6} \ln a$.
1330. -2. **1331.** 1. **1332.** $\left(\frac{a}{b}\right)^2$. **1333.** $\frac{1}{6}$. **1334.** $\frac{2}{3}$. **1335.** 1. **1336.** 0. **1337.** 0. **1338.** 0. **1339.** 0.
1340. 0. **1341.** 0. **1342.** 1. **1343.** 1. **1344.** -1. **1345.** e^k . **1346.** e^{-1} . **1347.** $e^{2/p}$. **1348.** e^{-1} . **1349.** 1.
1350. 1. **1351.** 1. **1352.** $e^{2/\sin 2a} \left(a \neq \frac{kp}{2}, k \in Z\right)$. **1353.** $e^{1/2(\ln^2 a - \ln^2 b)}$. **1354.** $\frac{1}{2}$. **1355.** $\frac{1}{2}$. **1356.** 0.
1357. $-\frac{1}{2}$. **1358.** $a^a (\ln a - 1)$. **1359.** $-\frac{e}{2}$. **1360.** $\frac{1}{a}$. **1361.** $e^{-2/p}$. **1362.** 1. **1363.** $e^{1/6}$. **1363.1.** $e^{1/6}$.
1363.2. $e^{1/3}$. **1363.3.** $e^{-1/3}$. **1363.4.** $e^{-1/6}$. **1364.** $e^{-1/2}$. **1365.** $e^{-2/p}$. **1366.** e^{-1} . **1367.** $\frac{mn}{n-m}$. **1368.**
 \sqrt{e} . **1368.1.** 0. **1369.** $-\frac{1}{6}$. **1370.** a . **1371.** $\operatorname{tg} a$. **1373.1.** $f'(0) = -\frac{1}{12}$. **1373.2.** $y = \frac{1}{e} \left(x + \frac{1}{2}\right)$.
1374. a) Lopital' qoidasini qo'llab bo'lmaydi, limit nolga teng; b) Lopital' qoidasini qo'llab bo'lmaydi, limit birga teng; v) formal qo'llangan Lopital' qoidasi 0 ga teng noto'g'ri natijani beradi, limit mavjud emas; g) formal qo'llangan Lopital' qoidasi 0 ga teng noto'g'ri natijani beradi, limit mavjud emas. **1375.** $\frac{4}{3}$. **1376.** $5 - 13(x+1) + 11(x+1)^2 - 2(x+1)^3$. **1377.**
 $1 + 2x + 2x^2 - 2x^4 + o(x^4)$; -48. **1378.** $1 + 60x + 1950x^2 + o(x^2)$. **1379.**
 $a + \frac{x}{ma^{m-1}} - \frac{(m-1)x^2}{2m^2 a^{2m-1}} + o(x^2)$. **1380.** $\frac{1}{6}x^2 + x^3 + o(x^3)$. **1381.**
 $1 + 2x + x^2 - \frac{2}{3}x^3 - \frac{5}{6}x^4 - \frac{1}{15}x^5 + o(x^5)$. **1382.** $1 - \frac{x}{2} + \frac{x^3}{12} - \frac{x^3}{720} + o(x^4)$. **1383.** $x - \frac{x^7}{18} - \frac{x^{13}}{3240} +$
 $+ o(x^{13})$. **1384.** $-\frac{x^2}{2} - \frac{x^4}{12} - \frac{x^6}{45} + o(x^6)$. **1385.** $x - \frac{x^3}{3} + o(x^3)$. **1386.** $x + \frac{x^3}{3} + \frac{2x^5}{15} + o(x^5)$. **1387.**
 $-\frac{x^2}{6} - \frac{x^4}{180} - \frac{x^6}{2835} + o(x^6)$. **1388.** $1 + \frac{1}{2}(x-1) - \frac{1}{8}(x-1)^2 + o((x-1)^2)$. **1389.** $(x-1) + (x-1)^2 +$
 $+ \frac{1}{2}(x-1)^3 + o((x-1)^3)$. **1390.** $y = a + \frac{x^2}{2a} + o(x^2)$. **1391.** $\frac{1}{2x} - \frac{1}{8x^3} + o\left(\frac{1}{x^3}\right)$. **1392.**
 $\ln x + \frac{h}{x} - \frac{h^2}{2x^2} + \dots + (-1)^{n-1} \frac{h^n}{nx^n} + o(h^n)$. **1394.** a) $\frac{3}{(n+1)!}$ dan kichik; b) $\frac{1}{3840}$
 $2 \cdot 10^{-6}$ dan kichik; g) $\frac{1}{16}$ dan kichik. **1395.** $|x| < 0,222 = \operatorname{arc} 12^\circ 30'$. **1396.** a) 3,1072; b) 3,0171; v)
1,9961; g) 1,64872; d) 0,309017; e) 0,182321; j) 0,67474 = $\operatorname{arc} 38^\circ 39' 35''$; z)
0,46676 = $\operatorname{arc} 26^\circ 44' 37''$; i) 1,12117. **1397.** a) 2,718281828; b) 0,01745241; v) 0,98769; g) 2,2361;
d) 1,04139. **1398.** $-\frac{1}{12}$. **1399.** $\frac{1}{3}$. **1400.** $-\frac{1}{4}$. **1401.** $\frac{1}{3}$. **1402.** $\frac{1}{6}$. **1403.** $\ln^2 a$. **1404.** $\frac{1}{2}$. **1405.** 0.
1406. $\frac{1}{3}$. **1406.1.** $\frac{19}{90}$. **1406.2.** $\frac{1}{2}$. **1406.3.** $\frac{1}{2}$. **1407.** $\frac{x^7}{30}$. **1408.** x^2 . **1409.** $\frac{x}{2}$. **1410.** $a = \frac{4}{3}$;
 $b = -\frac{1}{3}$. **1410.1.** $A = -\frac{2}{5}$; $B = -\frac{1}{15}$. **1410.2.** $A = \frac{1}{2}$; $B = \frac{1}{12}$; $C = -\frac{1}{2}$; $D = \frac{1}{12}$. **1411.** a) $\frac{2x}{R^3}$; b)
 $\frac{4}{3}x$; v) $\frac{An}{100}$; g) $\frac{70}{x}$. **1412.** $a = \frac{2}{3}$; $b = \frac{1}{3}$. **1413.** $\frac{a^4}{180}$, bunda a - yoy markaziy burchagining

yarmi. **1414.** $x = \frac{1}{2}$ da $y = 2\frac{1}{4}$ ga teng maksimum. **1415.** Ekstremumi yo`q. **1416.** $x = 1$ da $y = 0$ ga teng minimum. **1417.** Agar m juft bo`lsa, $x = 0$ da $y = 0$ ga teng minimum; agar m toq bo`lsa, $x = 0$ da ekstremum yo`q; agar n juft bo`lsa, $x = \frac{m}{m+n}$ da $y = \frac{m^m n^n}{(m+n)^{m+n}}$ ga teng maksimum va $x = 1$ da $y = 0$ ga teng minimum; agar n toq bo`lsa, $x = 1$ da ekstremum yo`q. **1418.** $x = 0$ da $y = 2$ minimum. **1419.** $x = -1$ da $y = 0$ minimum; $x = 9$ da $y = 10^{10} e^{-9} \approx 1\,234\,000$ maksimum. **1420.** Agar n toq bo`lsa, $x = 0$ da $y = 1$ maksimum, agar n juft bo`lsa, $x = 0$ da ekstremum yo`q. **1421.** $x = 0$ da $y = 0$ minimum. **1422.** $x = \frac{1}{3}$ da $y = \frac{1}{3}\sqrt[3]{4} \approx 0,529$ maksimum; $x = 1$ da $y = 0$ minimum; $x = 0$ da ekstremum yo`q. **1423.** Agar $j(x_0) > 0$ va n juft bo`lsa, $f(x_0) = 0$ minimum; agar $j(x_0) < 0$ va n juft bo`lsa, $f(x_0) = 0$ maksimum; agar n toq bo`lsa, $f(x_0)$ – ekstremum emas. **1425.** Yo`q. **1427.** a) Minimum $f(0) = 0$; b) minimum $f(0) = 0$. **1428.** Minimum $f(0) = 0$. **1429.** $x = 1$ da $y = 0$ maksimum; $x = 3$ da $y = -4$ minimum. **1430.** $x = 0$ da $y = 0$ minimum; $x = \pm 1$ da $y = 1$ maksimum. **1431.** $x = \frac{5 - \sqrt{13}}{6} \approx 0,23$ da $y \approx -0,76$ minimum; $x = 1$ da $y = 0$ maksimum; $x = \frac{5 + \sqrt{13}}{6} \approx 1,43$ da $y \approx -0,05$ minimum; $x = 2$ da ekstremum yo`q. **1432.** $x = -1$ da $y = -2$ maksimum; $x = 1$ da $y = 2$ minimum. **1433.** $x = -1$ da $y = -1$ minimum; $x = 1$ da $y = 1$ maksimum. **1434.** $x = \frac{7}{5}$ da $y = -\frac{1}{24}$ minimum. **1435.** $x = 0$ va $x = 2$ da $y = 0$ chegaraviy minimum; $x = 1$ da $y = 1$ maksimum. **1436.** $x = \frac{3}{4}$ da $y = -\frac{3}{8}\sqrt{2} \approx -0,46$ minimum; $x = 1$ da ekstremum yo`q. **1437.** $x = 1$ da $y = e^{-1} \approx 0,368$ maksimum. **1438.** $x = +0$ da $y = 0$ chegaraviy maksimum; $x = e^{-2} \approx 0,135$ da $y = -\frac{2}{e} \approx -0,736$ minimum. **1439.** $x = 1$ da $y = 0$ minimum; $x = e^2 \approx 7,389$ da $y = \frac{4}{e^2} \approx 0,541$ maksimum. **1440.** $x = kp$ ($k = 0, \pm 1, \pm 2, \dots$) larda $y = (-1)^k + \frac{1}{2}$ maksimum; $x = \pm \frac{2p}{3} + 2kp$ ($k = 0, \pm 1, \pm 2, \dots$) larda $y = -\frac{3}{4}$ minimum. **1441.** $x = kp$ ($k = 0, \pm 1, \pm 2, \dots$) larda $y = 10$ maksimum; $x = p\left(k + \frac{1}{2}\right)$ ($k = 0, \pm 1, \pm 2, \dots$) larda $y = 5$ minimum. **1442.** $x = 1$ da $y = \frac{p}{4} - \frac{1}{2} \ln 2 \approx 0,439$ maksimum. **1443.** $x = -\frac{p}{4} + 2pk$ ($k \in Z$) larda $y = -\frac{\sqrt{2}}{2} e^{-p/4+2kp}$ minimum; $x = \frac{3p}{4} + 2kp$ ($k \in Z$) larda $y = \frac{\sqrt{2}}{2} e^{3p/4+2kp}$ maksimum. **1444.** $x = -1$ da $y = e^{-2} \approx 0,135$ maksimum; $x = 0$ da $y = 0$ minimum; $x = 1$ da $y = 1$ maksimum. **1445.** $\frac{1}{2}$; 32. **1446.** 2; 66. **1447.** 0; 132. **1448.** 2; 100,01. **1449.** 1; 3. **1450.** 0; $\frac{100}{e} \approx 36,8$. **1451.** 0; 1. **1452.** 0; $\frac{1}{2}(1 + \sqrt{2}) \approx 1,2$. **1453.** $-\frac{\sqrt{2}}{2} e^{-3p/4} \approx -0,067$; 1. **1454.** Agar $-\infty < x \leq -3$ bo`lsa, $m(x) = -\frac{1}{6}$; agar $-3 < x \leq -1$ bo`lsa, $m(x) = \frac{1+x}{3+x^2}$; agar $-1 < x < +\infty$ bo`lsa, $m(x) = 0$; agar

$-\infty < x \leq 1$ bo`lsa, $M(x) = \frac{1}{2}$; agar $1 < x < +\infty$ bo`lsa, $M(x) = \frac{1+x}{3+x^2}$. **1455.** a) $\frac{14^{10}}{2^{14}} \approx 1,77 \cdot 10^7$;

b) $\frac{1}{200}$; v) $\sqrt[3]{3} \approx 1,44$. **1457.** $\frac{9+6\sqrt{3}}{4} \approx 4,85$. **1458.** $q = -\frac{1}{2}$. **1459.** $\frac{4}{27}$. **1460.** $g(x) =$
 $= (x_1 + x_2)x - \frac{1}{8}(x_1^2 + x_2^2 + 6x_1x_2)$; $\Delta = \frac{1}{8}(x_1 - x_2)^2$. **1461.** $\frac{2}{3}$.